



**Count on it.**

**Operator's Manual**

# Reelmaster® 5010-H Traction Unit

Model No. 03674—Serial No. 41300000 and Up

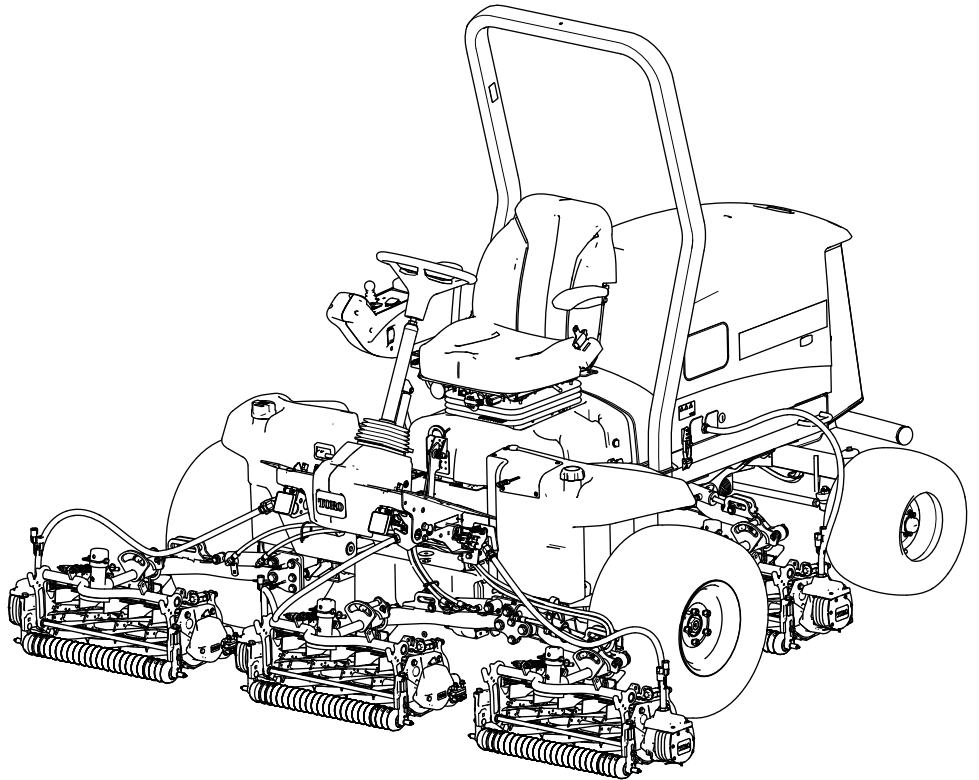

This product complies with all relevant European directives. For details, please see the separate product specific Declaration of Conformity (DOC) sheet.

It is a violation of California Public Resource Code Section 4442 or 4443 to use or operate the engine on any forest-covered, brush-covered, or grass-covered land unless the engine is equipped with a spark arrester, as defined in Section 4442, maintained in effective working order or the engine is constructed, equipped, and maintained for the prevention of fire.

The enclosed engine owner's manual is supplied for information regarding the US Environmental Protection Agency (EPA) and the California Emission Control Regulation of emission systems, maintenance, and warranty. Replacements may be ordered through the engine manufacturer.

### **⚠ WARNING**

#### **CALIFORNIA Proposition 65 Warning**

**Diesel engine exhaust and some of its constituents are known to the State of California to cause cancer, birth defects, and other reproductive harm.**

**Battery posts, terminals, and related accessories contain lead and lead compounds, chemicals known to the State of California to cause cancer and reproductive harm. Wash hands after handling.**

**Use of this product may cause exposure to chemicals known to the State of California to cause cancer, birth defects, or other reproductive harm.**

## **Introduction**

This machine is a ride-on, reel-blade lawn mower intended to be used by professional, hired operators in commercial applications. It is primarily designed for cutting grass on well-maintained turf. Using this product for purposes other than its intended use could prove dangerous to you and bystanders.

Read this information carefully to learn how to operate and maintain your product properly and to avoid injury and product damage. You are responsible for operating the product properly and safely.

Visit [www.Toro.com](http://www.Toro.com) for more information, including safety tips, training materials, accessory information, help finding a dealer, or to register your product.

Whenever you need service, genuine Toro parts, or additional information, contact an Authorized Service Dealer or Toro Customer Service and have the model and serial numbers of your product ready. **Figure 1** identifies the location of the model and serial numbers on the product. Write the numbers in the space provided.

**Important:** With your mobile device, you can scan the QR code on the serial number plate (if equipped) to access warranty, parts, and other product information.

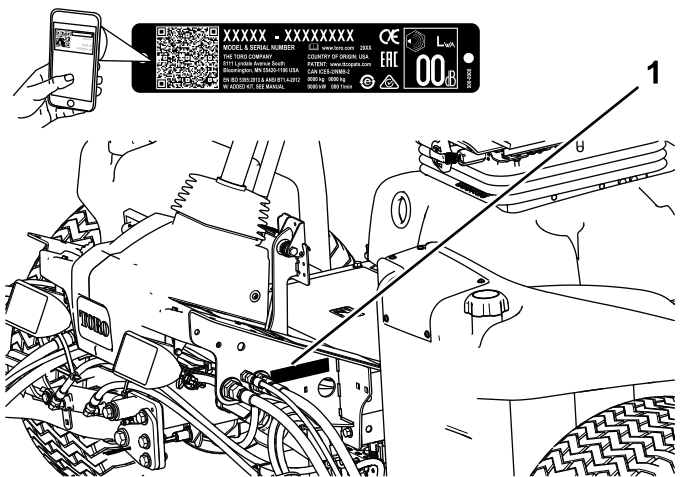

**Figure 1**

1. Model and serial number location

Model No. _____
Serial No. _____

This manual identifies potential hazards and has safety messages identified by the safety-alert symbol (**Figure 2**), which signals a hazard that may cause serious injury or death if you do not follow the recommended precautions.



**Figure 2**  
Safety-alert symbol

This manual uses 2 words to highlight information. **Important** calls attention to special mechanical information and **Note** emphasizes general information worthy of special attention.

# Contents

Safety .....	4	Separating the Generator Cooling-Air Shrouds .....	45
General Safety .....	4	Assembling the Generator Cooling-Air Shrouds .....	45
Safety and Instructional Decals .....	5	Jacking Point Locations .....	46
Setup .....	11	Lubrication .....	47
1 Preparing the Machine .....	11	Greasing the Bearings and Bushings .....	47
2 Adjusting the Control-Arm Position .....	12	Engine Maintenance .....	48
3 Installing the Cutting Units .....	12	Engine Safety .....	48
4 Mounting the Finishing Kits .....	18	Checking the Air Filter .....	48
5 Using the Cutting-Unit Kickstand .....	20	Servicing the Air Cleaner .....	49
6 Installing the 48 V Disconnect Jumper and Closing the Seat Base .....	20	Resetting the Air Filter Service Indicator .....	50
7 Installing the CE Hood Lock .....	21	Oil Specification .....	50
8 Applying the CE Decals .....	22	Checking the Level of the Engine Oil .....	50
Product Overview .....	23	Crankcase Oil Capacity .....	51
Controls .....	23	Changing the Engine Oil and Filter .....	51
Seat Controls .....	25	Fuel System Maintenance .....	52
Specifications .....	30	Draining Water from the Fuel-Water Separator .....	52
Attachments/Accessories .....	30	Replacing the Water-Separator Filter .....	52
Before Operation .....	31	Bleeding the Fuel System .....	53
Before Operation Safety .....	31	Checking the Fuel Lines and Connections .....	53
Fuel Specification .....	31	Draining the Fuel Tank .....	53
Fuel Tank Capacity .....	31	Cleaning the Fuel-Pickup Tube Screen .....	53
Adding Fuel .....	32	Electrical System Maintenance .....	56
Performing Daily Maintenance .....	32	Electrical System Safety .....	56
Checking the Interlock Switches .....	32	Disconnecting the 12 V Battery .....	56
Breaking in the Machine .....	33	Connecting the 12 V Battery .....	57
During Operation .....	33	Charging the 12 V Battery .....	57
During Operation Safety .....	33	Servicing the 12 V Battery .....	57
Starting the Engine .....	34	Replacing a 12 V Fuse-Block Fuse .....	58
Shutting Off the Engine .....	34	Replacing a 48 V Cutting Unit Fuse .....	58
Adjusting the Turf-Compensation Spring .....	34	Replacing the Reel Enable Fuse .....	59
Adjusting the Lift-Arm Counterbalance .....	35	Replacing the TEC Fuse .....	59
Adjusting the Lift-Arm Turnaround Position .....	35	Replacing the Telematic Fuse .....	60
Setting the Reel Speed .....	36	Drive System Maintenance .....	61
Understanding the Diagnostic Light .....	37	Checking the Tire Air Pressure .....	61
Operating Tips .....	37	Checking the Torque of the Wheel Nuts .....	61
After Operation .....	37	Adjusting the Traction Drive for Neutral .....	61
After Operation Safety .....	37	Checking the Rear-Wheel Alignment .....	62
Tie-Down Point Locations .....	38	Adjusting the Rear Wheel Toe-in .....	62
Hauling the Machine .....	38	Cooling System Maintenance .....	63
Pushing or Towing the Machine .....	38	Cooling System Safety .....	63
Maintenance .....	39	Coolant Specification .....	63
Maintenance Safety .....	39	Checking the Coolant Level .....	63
Recommended Maintenance Schedule(s) .....	39	Removing Debris from the Cooling System .....	64
Daily Maintenance Checklist .....	41	Brake Maintenance .....	65
Pre-Maintenance Procedures .....	43	Adjusting the Parking Brakes .....	65
Preparing for Maintenance .....	43	Adjusting the Parking-Brake Latch .....	65
Opening the Hood .....	43	Belt Maintenance .....	66
Closing the Hood .....	43	Tensioning the Alternator Belt .....	66
Opening the Screen .....	43	Hydraulic System Maintenance .....	67
Closing the Screen .....	44	Hydraulic System Safety .....	67
Tilting the Seat .....	44	Hydraulic Fluid Specification .....	67
Lowering the Seat .....	44	Checking the Hydraulic-Fluid Level .....	67

Checking the Hydraulic Lines and Hoses.....	68
Changing the Charge Filter .....	68
Checking for Leaks .....	68
Hydraulic Fluid Capacity .....	68
Changing the Hydraulic Fluid .....	69
Cutting Unit System Maintenance .....	70
Blade Safety .....	70
Checking the Reel-to-Bedknife Contact .....	70
Backlapping the Cutting Units .....	70
Chassis Maintenance .....	71
Inspecting the Seat Belt .....	71
Extended Maintenance .....	72
Chassis and Engine .....	72
Cleaning .....	72
Washing the Machine .....	72
Storage .....	73
Storage Safety .....	73
Preparing the Traction Unit .....	73
Preparing the Engine .....	73
Storing the Battery .....	73

# Safety

This machine has been designed in accordance with EN ISO 5395 (when you complete the setup procedures) and ANSI B71.4-2017.

## General Safety

This product is capable of amputating hands and feet and of throwing objects.

- Read and understand the contents of this *Operator's Manual* before starting the engine.
- Use your full attention while operating the machine. Do not engage in any activity that causes distractions; otherwise, injury or property damage may occur.
- Do not put your hands or feet near moving components of the machine.
- Do not operate the machine without all guards and other safety protective devices in place and functioning properly on the machine.
- Keep bystanders and children out of the operating area. Never allow children to operate the machine.
- Shut off the engine, remove the key, and wait for all movement to stop before you leave the operator's position. Allow the machine to cool before adjusting, servicing, cleaning, or storing it.

Improperly using or maintaining this machine can result in injury. To reduce the potential for injury, comply with these safety instructions and always pay attention to the safety-alert symbol , which means Caution, Warning, or Danger—personal safety instruction. Failure to comply with these instructions may result in personal injury or death.



# Safety and Instructional Decals



Safety decals and instructions are easily visible to the operator and are located near any area of potential danger. Replace any decal that is damaged or missing.



## Battery Symbols

Some or all of these symbols are on your battery

- |  |   |
|--|---|
| 1. Explosion hazard                    | 6. Keep bystanders away from the battery.                                       |
| 2. No fire, open flame, or smoking     | 7. Wear eye protection; explosive gases can cause blindness and other injuries. |
| 3. Caustic liquid/chemical burn hazard | 8. Battery acid can cause blindness or severe burns.                            |
| 4. Wear eye protection.                | 9. Flush eyes immediately with water and get medical help fast.                 |
| 5. Read the <i>Operator's Manual</i> . | 10. Contains lead; do not discard; recycle                                      |

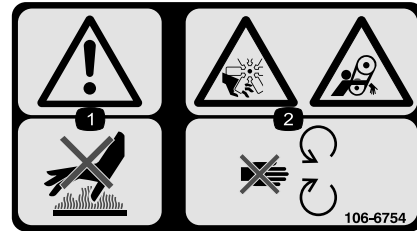

106-6754

decal106-6754

- Warning—do not touch the hot surface.
- Cutting/dismemberment hazard, fan; entanglement hazard, belt—stay away from moving parts.



106-6755

decal106-6755

- Engine coolant under pressure.
- Explosion hazard—read the *Operator's Manual*.
- Warning—do not touch the hot surface.
- Warning—read the *Operator's Manual*.

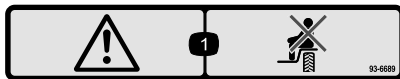

93-6689

decal93-6689

- Warning—do not carry passengers.



93-6696

decal93-6696

- Stored energy hazard—read the *Operator's Manual*.

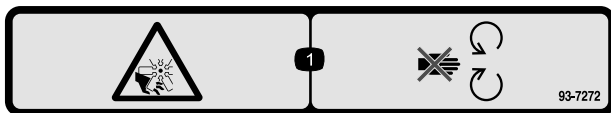

93-7272

decal93-7272

- Cutting/dismemberment hazard; fan—stay away from moving parts.

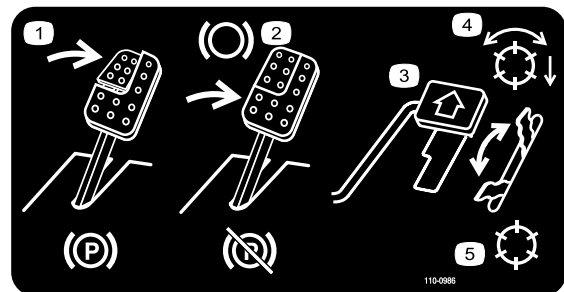

110-0986

decal110-0986

- Press the brake pedal and parking brake pedal to set the parking brake.
- Press the brake pedal to apply the brake.
- Press the traction pedal to move the machine forward.
- Reel enabled mode
- Transport mode

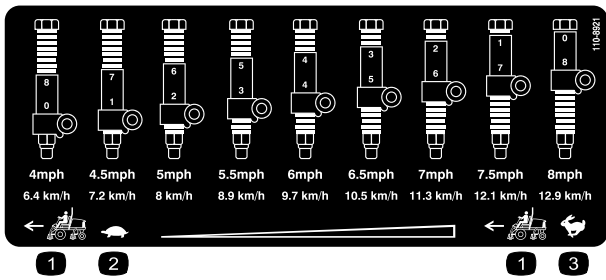

110-8921

decal110-8921

1. Traction unit speed
2. Slow
3. Fast

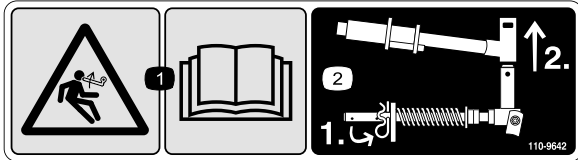

110-9642

decal110-9642

1. Stored energy hazard—read the *Operator's Manual*.
2. Move the cotter pin to the hole closest to the rod bracket and then remove the lift arm and pivot yoke.

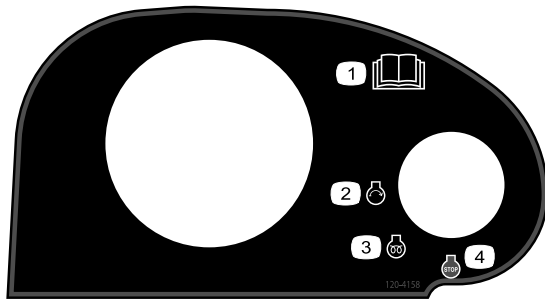

120-4158

decal120-4158

1. Read the *Operator's Manual*.
2. Engine—start
3. Engine—preheat
4. Engine—stop

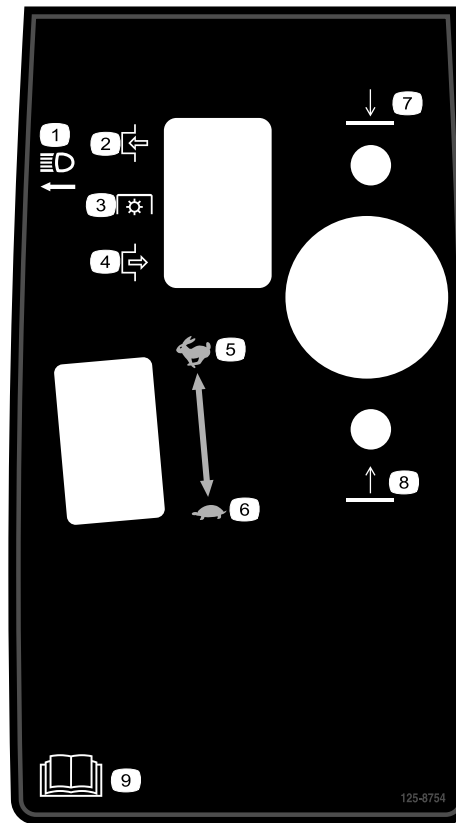

125-8754

decal125-8754

1. Headlights
2. Engage
3. Power take-off (PTO)
4. Disengage
5. Fast
6. Slow
7. Lower the cutting units
8. Raise the cutting units
9. Read the *Operator's Manual*.

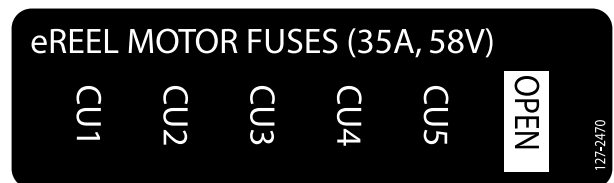

127-2470

decal127-2470

**⚠ WARNING: Cancer and Reproductive Harm - [www.P65Warnings.ca.gov](http://www.P65Warnings.ca.gov).**  
 For more information, please visit [www.ttcocalprop65.com](http://www.ttcocalprop65.com)  
**CALIFORNIA SPARK ARRESTER WARNING**  
 Operation of this equipment may create sparks that can start fires around dry vegetation. A spark arrester may be required. The operator should contact local fire agencies for laws or regulations relating to fire prevention requirements.

133-8062

decal133-8062

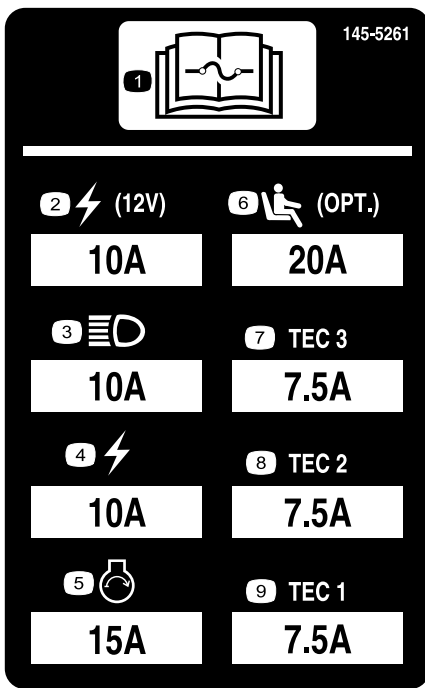

decal145-5261

**145-5261**

- |  |  |                   |
|--|--|-------------------|
| 1. Read the <i>Operator's Manual</i> for fuse information. | 4. Electric                            | 7. TEC controller |
| 2. Power point (12 V)                                      | 5. Engine start                        | 8. TEC controller |
| 3. Headlights  | 6. Air ride seat suspension (optional) | 9. TEC controller |

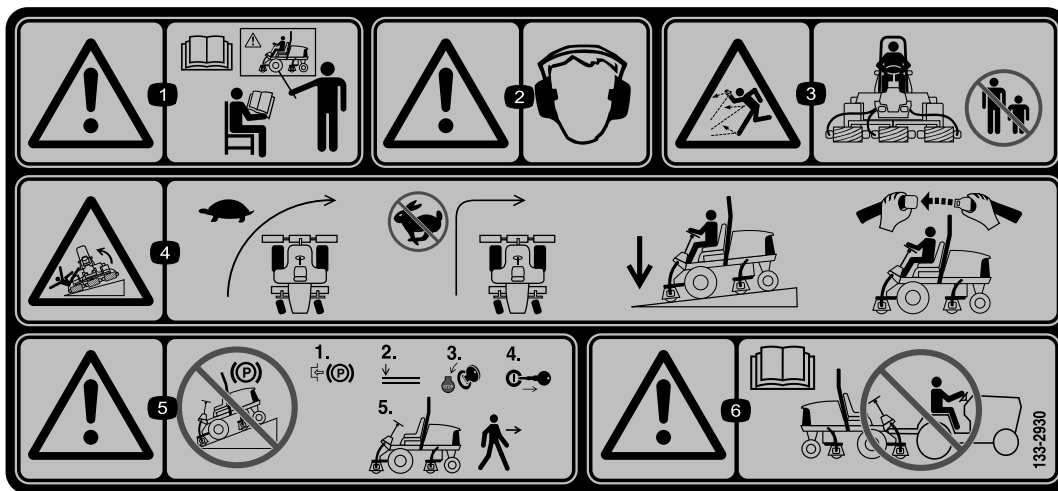

decal133-2930

**133-2930**

- |  |   |
|--|---|
| 1. Warning—do not operate this machine unless you are trained.     | 4. Tipping hazard—drive slowly when turning; do not turn sharply while traveling fast; only drive on slopes with the cutting units lowered; always wear a seatbelt. |
| 2. Warning—wear hearing protection.                                | 5. Warning—do not park on slopes; engage the parking brake, lower the cutting units, shut off the engine, and remove the ignition key before leaving the machine.   |
| 3. Thrown object hazard—keep bystanders out of the operating area. | 6. Warning—read the <i>Operator's Manual</i> ; do not tow the machine.  |



133-2931

decal133-2931

**Note:** This machine complies with the industry standard stability test in the static lateral and longitudinal tests with the maximum recommended slope indicated on the decal. Review the instructions for operating the machine on slopes in the *Operator's Manual* as well as the conditions in which you would operate the machine to determine whether you can operate the machine in the conditions on that day and at that site. Changes in the terrain can result in a change in slope operation for the machine. If possible, keep the cutting units lowered to the ground while operating the machine on slopes. Raising the cutting units while operating on slopes can cause the machine to become unstable.

1. Warning—read the *Operator's Manual*; do not operate this machine unless you are trained.
2. Warning—wear hearing protection.
3. Thrown object hazard—keep bystanders away.
4. Tipping hazard—do not drive across or down slopes greater than 15°; only drive on slopes with the cutting units lowered; always wear a seatbelt.
5. Warning—do not park on slopes; engage the parking brake, lower the cutting units, shut off the engine, and remove the ignition key before leaving the machine.
6. Warning—read the *Operator's Manual*; do not tow the machine.

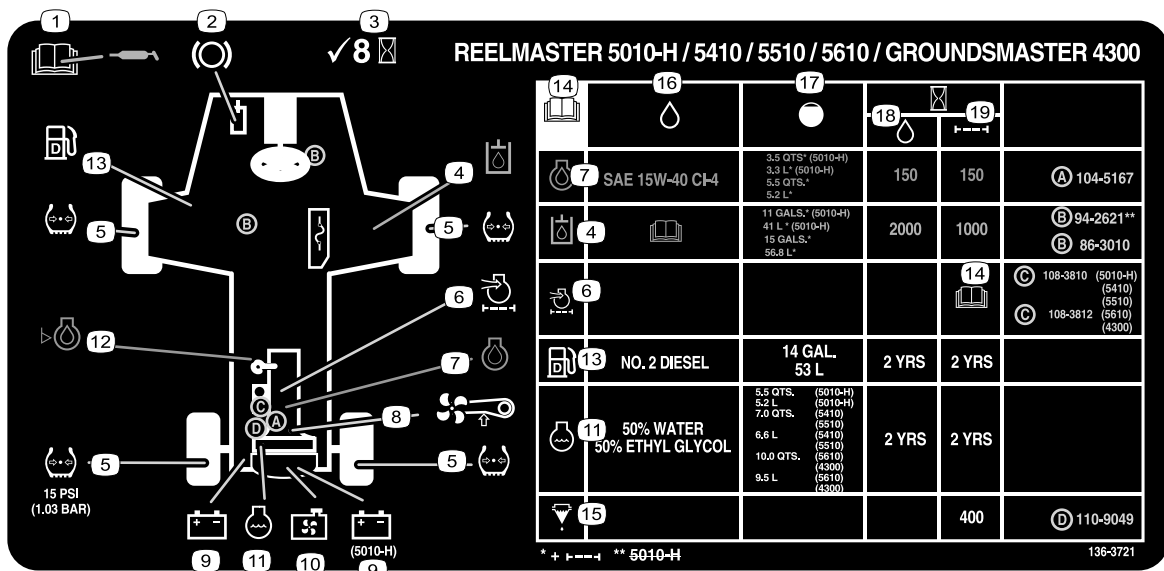

decal136-3721

**136-3721**

- |   |                      |   |                             |
|---|----------------------|---|-----------------------------|
| 1. Read the <i>Operator's Manual</i> for lubrication information. | 6. Engine air filter | 11. Engine coolant                      | 16. Fluids                  |
| 2. Brake functions  | 7. Engine oil        | 12. Engine oil level                    | 17. Capacity                |
| 3. Check every 8 hours.   | 8. Fan belt          | 13. Fuel                                | 18. Fluid interval (hours)  |
| 4. Hydraulic fluid  | 9. Battery           | 14. Read the <i>Operator's Manual</i> . | 19. Filter interval (hours) |
| 5. Tire pressure  | 10. Radiator screen  | 15. Fuel/Water separator                |                             |

**HANKOOK**  
**AGM 35-650**  
NON-SPILLABLE, Lead Acid Battery

Manufactured by:  
Hankook AtlasBX Co., Ltd.  
185, Daejeon-ro 1331beon-gil, Daedeok-gu  
Daejeon 34365, Korea  
T +38 42 620 4242

**TORO PART**  
#136-3726  
55.0Ah/12Vdc

decal136-3731

**136-3731**

- |  |  |
|--|--|
| 1. Read the <i>Operator's Manual</i> . | 5. Caustic liquid/chemical burn hazard |
| 2. Wear eye protection                 | 6. Explosion hazard                    |
| 3. No fire, open flame, or smoking     | 7. Contains lead; do not discard       |
| 4. Keep bystanders away                |  |

136-3732



**PELIGRO**

**1** **2** **3** **4** **5**

**La batería de plomo-ácido contiene: plomo, ácido sulfúrico (electrolito), compuestos de plomo.**

Respiración si se ingiere, inhaló o entró en contacto con la piel. El ácido provoca graves quemaduras en la piel y daño en los ojos. Puede perforar la membrana o el tubo roto si se ingiere o inhala. Evitar ser proyectado para los niños en bicicleta. Nunca provocar caída si se ingiere o inhala. Provoca irritación en la piel y grave daño en los ojos.

El contacto con componentes internos puede provocar irritación o quemaduras graves. Provoca daño al sistema nervioso central, sangre y riñones con la exposición prolongada o repetida si se ingiere o inhala. Evitar para los ojos. Evitar respiración. No fumar. Puede formar una combinación explosiva de aire al estar a la carga. Una extracción incorrecta de hidrógeno, hidrógeno, plomo de sulfato, mercurio, metales y propiedades. Consultar instrucciones especiales antes de usar. No manipule hasta que todas las precauciones de seguridad se hayan leído y comprendido. Limpiar meticulosamente después de la manipulación. No comer, beber o fumar cuando se usa este producto. Evitar el contacto durante el embalaje/retiro. Usar guantes de protección, vestimenta de protección, protección para los ojos y protección para el rostro, usar únicamente en el exterior o en áreas bien ventiladas.

Evitar el contacto con el ácido interno. No respirar el polvo/aerosol/vapor/metano/ácido sulfúrico. Mantener alejado de calor/fuertes temperaturas colisiones. No fumar/SE RIESGO O CONSUMIR: evitar que la boca, no inducir al vómito, llamar al centro toxicológico/médico o no se debe lavar/SE RIESGO EN CONTACTO CON LA PIEL O LA RES: evadir contacto repetitivo de inmediato toda la ropa contaminada y lavar antes de volver. Evitar que la piel con quemaduras. SE RIESGO A través de la piel y/o membranas de una posición correcta para respirar. Llamar de inmediato al CENTRO TOXICOLÓGICO o al médico. EVITAR EN CONTACTO CON LOS OJOS: enjuagar con agua abundante con agua durante varios minutos. Retirar lentes de contacto si se usan y si es fácil hacerlo. Continuar enjuagando. Si se experimenta picazón, o si no se siente bien luego de aplicar/uso inmediato médico. Evitar que la piel, no se debe lavar, según las regulaciones locales y nacionales. Eliminar el contenido/contenedor según las regulaciones locales y nacionales. Nunca lavar del interior de los niños.

**ADVERTENCIA:** riesgo de incendio, explosión o quemadura. No desarmar ni recivar. No se recomienda para uso infantil. Seguir las instrucciones de carga del producto. **ALTO VOLTAJE:** riesgo de shock. No tocar las terminales o conexiones de soldadura. No reír las válvulas de ventilación.

**Contient : Plomb, Acide sulfurique (Électrolyte), Composés de plomb.**

Inhalation si on respire, s'hydrate ou de contact avec la peau. L'acide provoque de graves brûlures de la peau et des lésions oculaires. Peut nuire à la fertilité ou au fœtus si ingéré ou inhalé. Peut être nocif pour une entente marine si versé. Peut provoquer la chute si ingéré ou inhalé. Provoque une irritation de la peau, et de graves lésions oculaires. Un contact avec des composants internes de ce produit peut provoquer une irritation ou de graves brûlures. Provoque des lésions au système nerveux central, aux tissus sanguinifères et aux reins par une exposition prolongée ou répétée si ingéré ou inhalé. Une source d'irritation pour les yeux. Éviter respirations et la peau. Peut former un mélange explosif au contact de l'air lors de la charge de la batterie. Une extraction incorrecte de l'hydrogène, l'hydrogène, le plomb, le sulfate de plomb, le mercure, les métaux et les propriétés. Consulter les instructions spéciales avant d'utiliser ce produit. Ne manipulez pas ce produit avant d'avoir lu et compris toutes les précautions de sécurité. Lavez-vous soigneusement les mains après avoir manipulé ce produit. Ne mangez pas, ne buvez pas et ne fumez pas en manipulant ce produit. Évitez tout contact avec ce produit pendant la grossesse/Maternité. Portez des gants de protection/évitez vêtements de protection, des protections oculaires/face, évitez ce produit seulement en plein air ou dans un endroit bien ventilé, Évitez tout contact avec l'acide contenu dans ce produit.

Ne respire pas les poussières/fumées de gaz/bulbilles/vapores/aérosols dégagés par ce produit. Tenir ce produit à l'écart de la chaleur/fortes températures sources surface chaudes. Il est interdit de fumer en présence de ce produit. En cas d'INGESTION OU DE CONSOMMATION: rincer avec la bouche/NE VOIEZ PAS VOMIR: rincer un centre antidote/toxicologie médicale en cas de malaise. En cas de REVERSEMENT SUR LES VÊTEMENTS OU LA PEAU (ou les cheveux): décontaminer immédiatement tout les vêtements contaminés et les laver avec de l'eau savonneuse. Rincer/ousser la peau à l'eau propre une douche. EN CAS D'IRRITATION: transporter la personne atteinte à l'hôpital, vérifier à ce qu'il ne soit contaminé, et consulter/ou si elle respire librement, Appeler immédiatement un CENTRE ANTIDOTE ou un toxicologue. En cas de CONTACT AVEC LES YEUX: rincer avec abondance à l'eau pendant plusieurs minutes. Éviter les vêtements de contact, ils sont portés et que vous pouvez facilement le faire. Continuez à rincer à l'eau. Si vous êtes exposé/contaminé, ou si vous vous sentez mal, faites-vous soigner ou consultez vos conseils médicaux. Gardez ce produit sous clé, dans un endroit bien aéré, conformément à la réglementation locale et nationale. Mettre le contenu/conteneur au rebut conformément à la réglementation locale et nationale. Ne pas ce produit hors de portée des enfants.

**AVERTISSEMENT:** Ce produit représente un risque d'incendie, d'explosion ou de brûlures. Ne le démontez pas ou ne l'ouvrez pas. Non recommandé pour une utilisation avec enfants. Suivre les instructions de recharge fournies avec ce produit. HAUT VOLTAJE: risque de choc. Ne touchez pas aux bornes ou aux connecteurs qui ne sont pas isolés. Ne retirez pas les verres d'isolation.

decal136-3732

## 136-3732

- |   |  |
|---|--|
| <ol style="list-style-type: none"> <li>1. Acute toxicity</li> <li>2. Aspiration hazard</li> <li>3. Flammable gases</li> </ol> | <ol style="list-style-type: none"> <li>4. Corrosive to metals/skin corrosion</li> <li>5. Environmental toxicity</li> </ol> |
|---|--|



# Setup

## Loose Parts

Use the chart below to verify that all parts have been shipped.

Procedure	Description	Qty.	Use
<b>1</b>	No parts required	–	Prepare the machine.
<b>2</b>	No parts required	–	Adjust the control-arm position.
<b>3</b>	Cutting units	5	Install the cutting units.
<b>4</b>	Finishing kit (sold separately)	1	Mount the finishing kits (finishing kits are sold separately).
<b>5</b>	Cutting-unit kickstand	1	Install the cutting-unit kickstand.
<b>6</b>	No parts required	–	Install the 48 V disconnect jumper and closing the seat base.
<b>7</b>	Hood lock, seal, and jam nut Washer	1 1	Install the CE hood lock.
<b>8</b>	CE decal Production year decal Warning decal	1 1 1	Apply the CE decals.

## Media and Additional Parts

Description	Qty.	Use
Key	2	Start the engine.
Operator's Manual	1	Read the Operator's Manual before operating the machine.
Engine owner's manual	1	Use the manual to reference engine information.
Declaration of Conformity	1	Declaration of conformity
Operator training material	1	Review the material before operating the machine.

**Note:** Determine the left and right sides of the machine from the normal operating position.

# 1

## Preparing the Machine

### No Parts Required

### Procedure

1. Park the machine on a level surface, lower the cutting units, and engage the parking brake.

2. Shut off the engine, remove the key, and wait for all moving parts to stop.
3. Check the tire air pressure before use; refer to [Checking the Tire Air Pressure \(page 61\)](#).

**Note:** The tires are overinflated for shipping. Adjust the tire air pressure before operating the machine.

4. Check the hydraulic-fluid level; refer to [Checking the Hydraulic-Fluid Level \(page 67\)](#).
5. Grease the machine; refer to [Greasing the Bearings and Bushings \(page 47\)](#).

**Important:** Failure to properly grease the machine will result in premature failure of critical parts.

- Open the hood and check the coolant level; refer to [Checking the Coolant Level \(page 63\)](#).
- Check the level of the engine-oil level, and close and latch the hood; refer to [Checking the Level of the Engine Oil \(page 50\)](#).

**Note:** The engine ships with oil in the crankcase; however, check the oil level before and after the engine is first started.

# 3

## Installing the Cutting Units

Parts needed for this procedure:

5	Cutting units
---	---------------

## Preparing the Machine

### ⚠ CAUTION

If you do not disconnect the power to the cutting units, someone could accidentally start the cutting unit, causing serious injury to hands and feet.

Always separate the power-disconnect connectors before working on the cutting units ([Figure 4](#)).

- Unlatch the seat base, tilt the seat and base open, and support it with the prop rods ([Figure 4](#)).

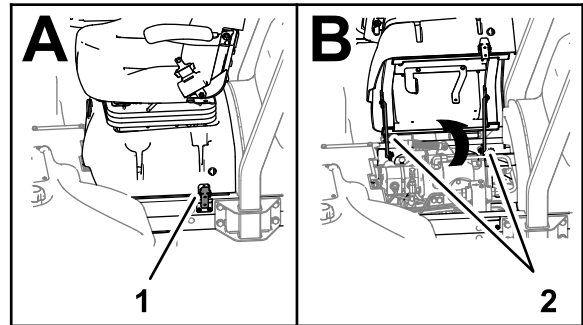

Figure 4

g375231

- Latch (seat base)
- Prop rods

- Unplugging the 48 VDC system battery-disconnect jumper ([Figure 5](#)).

# 2

## Adjusting the Control-Arm Position

No Parts Required

### Procedure

You can adjust the control-arm position your comfort.

- Loosen the 2 bolts securing the control arm to the retaining bracket ([Figure 3](#)).

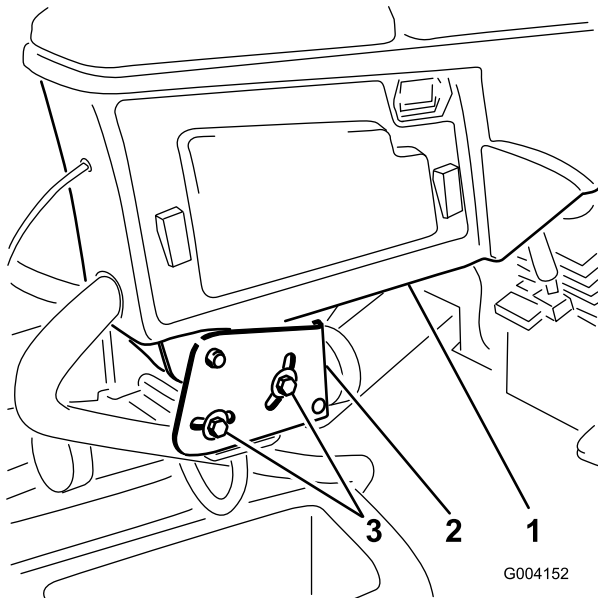

Figure 3

G004152

g004152

- Control arm
- Retaining brackets
- Bolts (2)

- Rotate the control arm to the desired position and tighten the 2 bolts.

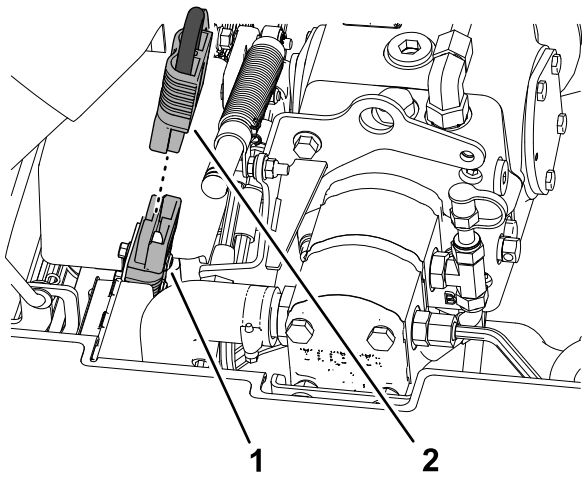
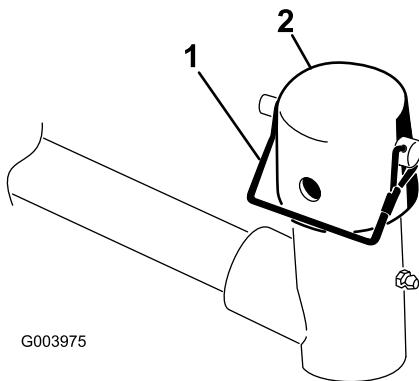

**Figure 5**

g375232

1. 48 V system connector
2. Battery-disconnect jumper

3. At each cutting unit lift arm, remove the snapper pin that secures the cap to the pivot yoke, and remove the cap (Figure 6).

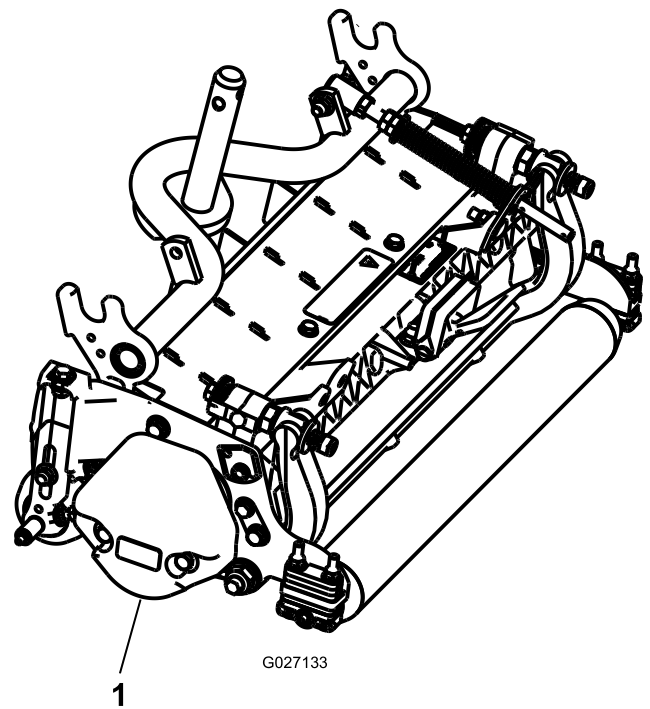

**Figure 6**

G003975

g003975

1. Snapper pin
2. Cap



G027133

**Figure 7**

g027133

1. Counterweight

4. Coat the carrier-frame shaft with clean grease (Figure 8).

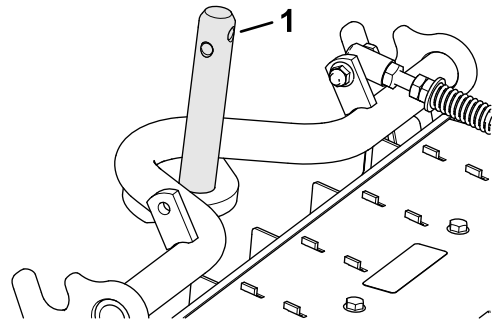

**Figure 8**

g375263

1. Carrier-frame shaft

5. Repeat steps 1 through 4 for the other cutting units.

## Preparing the Cutting Units

1. Remove the cutting units from the cartons.
2. Assemble and adjust as described in the cutting unit *Operator's Manual*.
3. Make sure that the counterweight (Figure 7) is installed at the proper end of the cutting unit as described in the cutting unit *Operator's Manual*.

# Positioning the Turf Compensating Spring

## Cutting Units 2 and 4

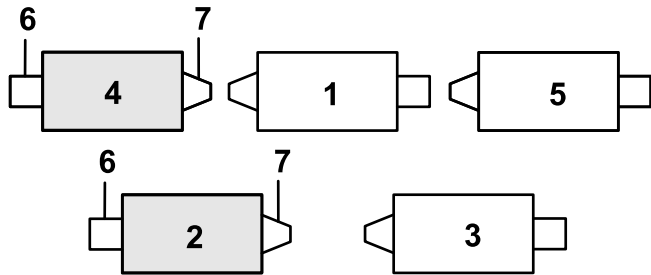

Figure 9

g378839

- |                   |                   |
|-------------------|-------------------|
| 1. Cutting unit 1 | 5. Cutting unit 5 |
| 2. Cutting unit 2 | 6. Reel motor     |
| 3. Cutting unit 3 | 7. Weight         |
| 4. Cutting unit 4 |                   |

1. If the hairpin is installed in the rear hole of the compensation-spring rod—remove the hairpin and insert it in the hole next to the bracket (Figure 10).

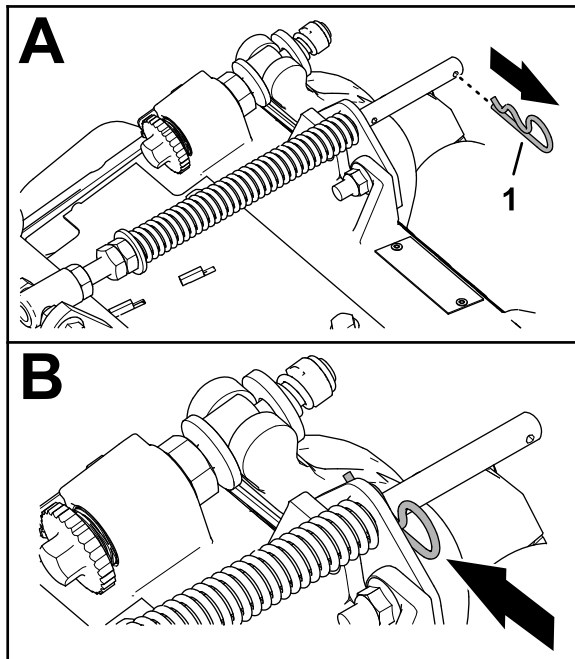

Figure 10

g375689

1. Hairpin
2. Remove the 2 flange locknuts (3/8 inch) and 2 carriage bolts (3/8 x 1-1/4 inches) that secure the turf-compensator bracket to the cutting-unit frame (Figure 11).

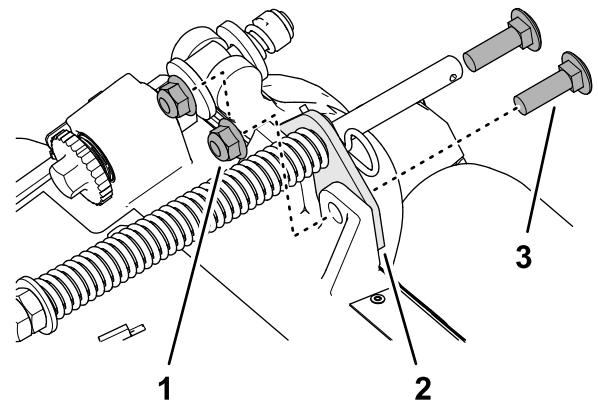

Figure 11

g375690

- |                                       |                              |
|---------------------------------------|------------------------------|
| 1. Carriage bolt (3/8 x 1-1/4 inches) | 3. Flange locknut (3/8 inch) |
| 2. Turf-compensator bracket           |                              |

3. Remove the flange locknut (3/8 inch) that secures the capscrew of the turf compensation spring to the right tab of the carrier frame, and remove the compensation spring from the cutting unit (Figure 12).

**Note:** Do not remove the flange serrated nut from the capscrew.

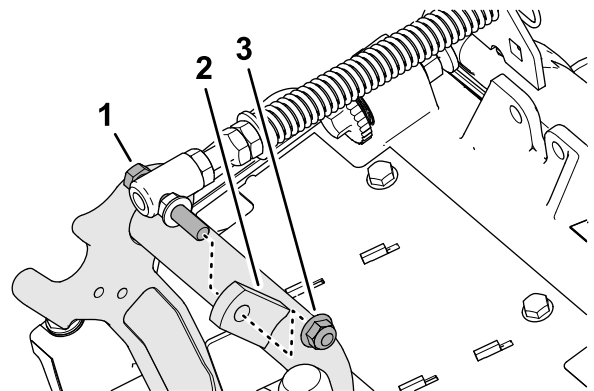
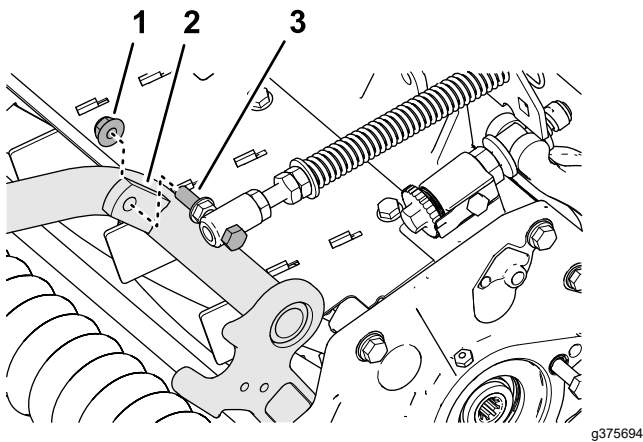

Figure 12

g375691

- |                              |                              |
|------------------------------|------------------------------|
| 1. Capscrew                  | 3. Flange locknut (3/8 inch) |
| 2. Right tab (Carrier frame) |                              |

4. Assemble the capscrew of the turf compensation spring to the right tab of the carrier frame (Figure 13) with the flange locknut (3/8 inch).



**Figure 13**

1. Flange locknut (3/8 inch)
2. Right tab (Carrier frame)
3. Capscrew

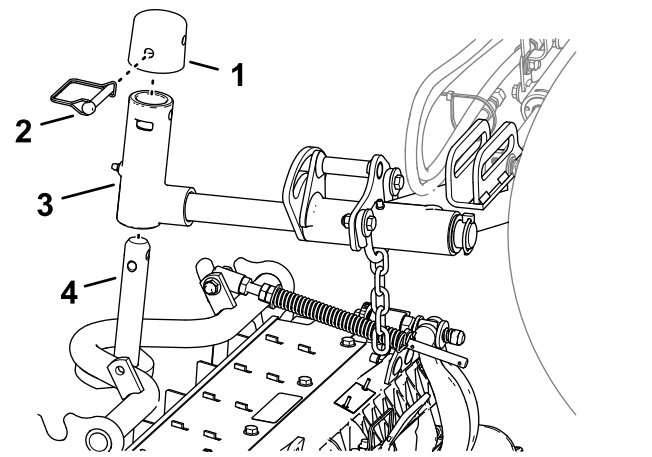
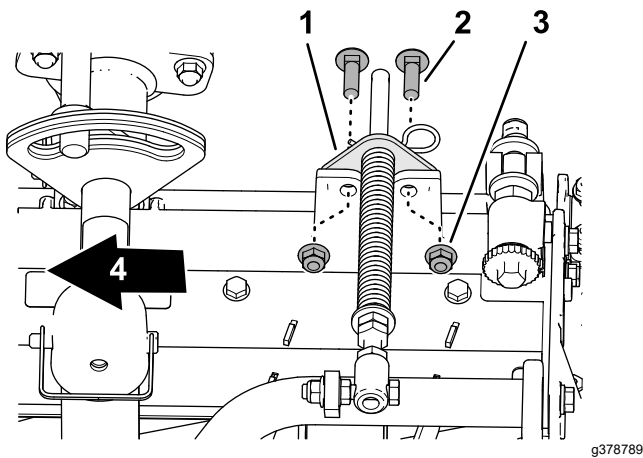

**Figure 15**

1. Cap
2. Snapper pin
3. Pivot yoke
4. Carrier frame shaft

5. Align the holes in the turf-compensator bracket with the holes in the cutting-unit frame (Figure 14).

**Note:** The support loop of the hose guide aligns toward the centerline of the machine.



**Figure 14**

1. Turf-compensator bracket
2. Carriage bolt (3/8 x 1-1/4 inches)
3. Flange locknut (3/8 inch)
4. Inboard inches

6. Assemble the turf-compensator bracket to the cutting-unit frame with the 2 carriage bolts (3/8 x 1-1/4 inches) and 2 flange locknuts (3/8 inch).
7. Torque the locknuts and bolts to 37 to 45 N·m (27 to 33 ft·lb).
8. Repeat steps 1 through 7 for the other cutting unit.

2. Assemble the pivot yoke onto the carrier frame shaft.
3. Assemble the cap to the pivot yoke, and align the holes in the carrier frame shaft, pivot yoke, and cap.
4. Secure the cap and the carrier-frame shaft to the pivot yoke with the snapper pin.

**Locking the Cutting-Unit Pivot for Cutting Grass on a Hill Side**—Lock the cutting-unit pivots to prevent the cutting units from rotating downhill when cutting across the face of a hill. Use the hole in the pivot yoke (Figure 16) to lock the cutting unit. Use the slot for a steering cutting unit.

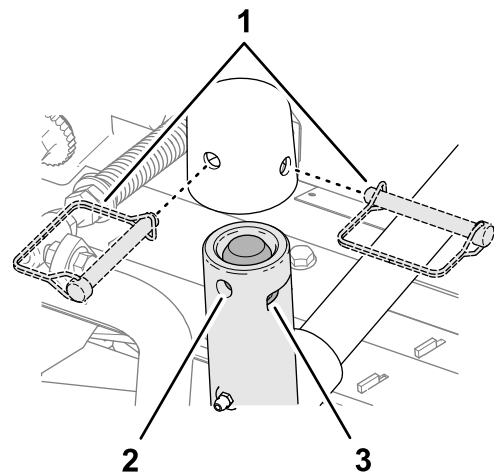

**Figure 16**

1. Snap-pin positions
2. Hole (lift-arm pivot shaft)
3. Slot (lift-arm pivot shaft)

## Installing the Front Cutting Units to the Lift Arms

1. Slide a cutting unit under the lift arm (Figure 15).

# Installing the Rear Cutting Units to the Lift Arms

## Cutting Units adjusted for a 1.2 cm (3/4 inch) or Higher Height of Cut

1. Slide a cutting unit under the lift arm (Figure 17).

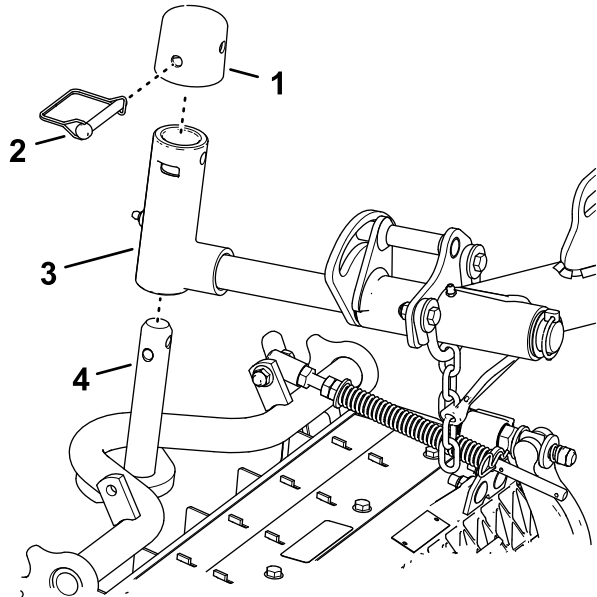

Figure 17

g375252

- |                |                        |
|----------------|------------------------|
| 1. Cap         | 3. Pivot yoke          |
| 2. Snapper pin | 4. Carrier frame shaft |

2. Assemble the pivot yoke onto the carrier frame shaft.
3. Assemble the cap to the pivot yoke and align the holes in the carrier frame shaft, pivot yoke, and cap.
4. Secure the pivot arm shaft and cap to the carrier frame shaft with the snapper pin.

**Locking the Cutting-Unit Pivot for Cutting Grass on a Hill Side**—Lock the cutting-unit pivots to prevent the cutting units from rotating downhill when cutting across the face of a hill. Use the hole in the pivot yoke (Figure 17) to lock the cutting unit. Use the slot for a steering cutting unit.

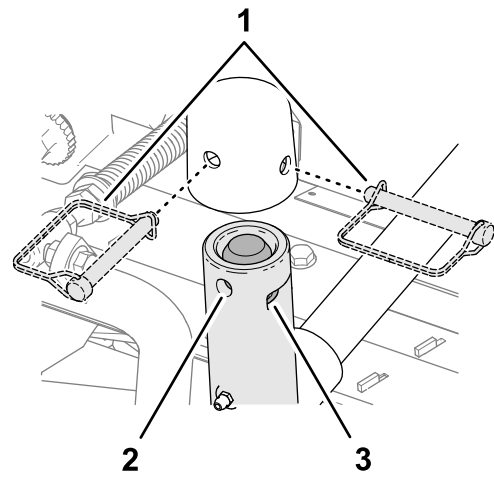

Figure 18

g375251

- |                          |                      |
|--------------------------|----------------------|
| 1. Snapper-pin positions | 3. Slot (pivot yoke) |
| 2. Hole (pivot yoke)     |                      |

5. Repeat steps 1 and 2 for the other rear cutting unit.

# Installing the Rear Cutting Units to the Lift Arms

## Cutting Units adjusted for a 1.2 cm (3/4 inch) or Lower Height of Cut

1. Remove the lynch pin and washer securing the to the pivot yoke to the lift arm, and slide the shaft out of the lift arm (Figure 19).

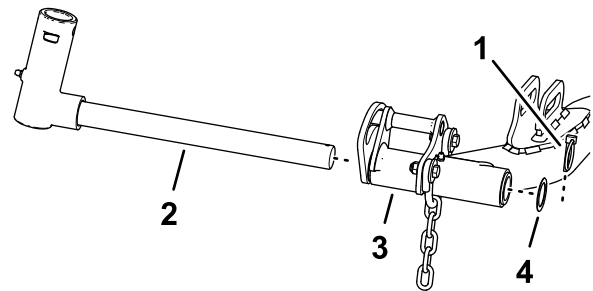

Figure 19

g375236

- |               |                                 |
|---------------|---------------------------------|
| 1. Lynch pin  | 3. Lift arm (rear cutting unit) |
| 2. Pivot yoke | 4. Washer                       |

2. Assemble the pivot yoke onto the carrier frame shaft (Figure 20).



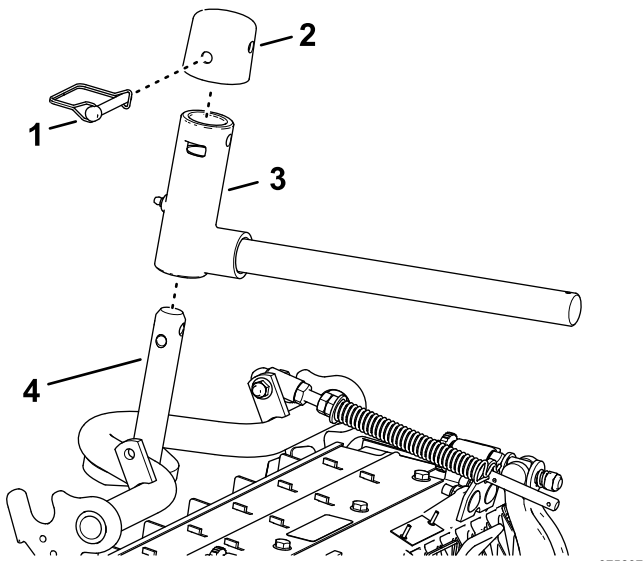
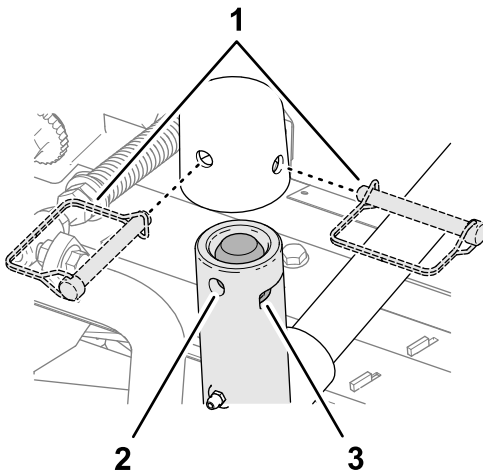

**Figure 20**

- |                |                        |
|----------------|------------------------|
| 1. Cap         | 3. Pivot yoke          |
| 2. Snapper pin | 4. Carrier frame shaft |

- Assemble the cap to the pivot yoke, and align the holes in the carrier frame shaft, pivot yoke, and cap.
- Secure the pivot yoke and cap to the carrier frame shaft with the snapper pin.

**Locking the Cutting-Unit Pivot for Cutting Grass on a Hill Side**—Lock the cutting-unit pivots to prevent the cutting units from rotating downhill when cutting across the face of a hill. Use the hole in the pivot yoke (Figure 21) to lock the cutting unit. Use the slot for a steering cutting unit.



**Figure 21**

- |                          |                      |
|--------------------------|----------------------|
| 1. Snapper-pin positions | 3. Slot (pivot yoke) |
| 2. Hole (pivot yoke)     |                      |

- Slide a cutting unit under the lift arm (Figure 22).

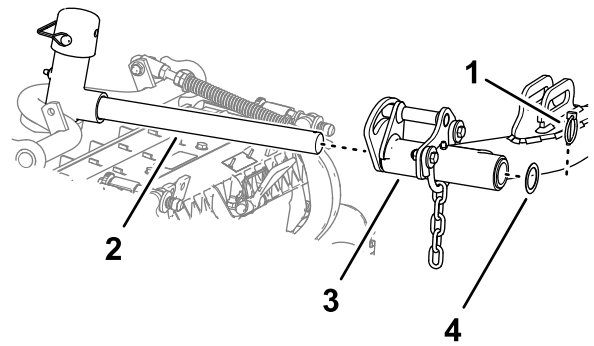

**Figure 22**

- |                   |             |
|-------------------|-------------|
| 1. Lynch pin      | 3. Lift arm |
| 2. Lift-arm shaft | 4. Washer   |

- Insert the pivot yoke into the lift arm, and secure shaft to the arm with the lynch pin and washer.
- Repeat steps 1 through 6 for the other rear cutting unit.

## Installing the Cutting Unit Lift-Arm Chains

Secure the lift-arm chain to the chain bracket with the snapper pin (Figure 23).

**Note:** Use the number of chain links described in the cutting unit *Operator's Manual*.

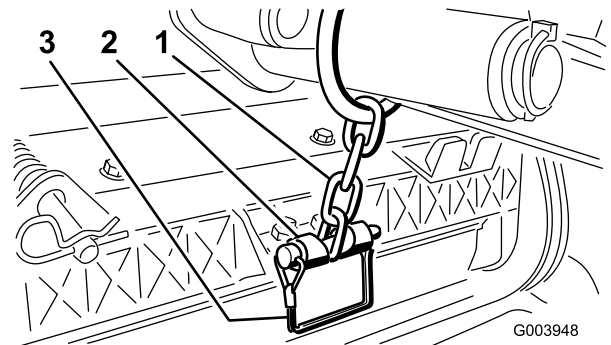

**Figure 23**

- |                   |                |
|-------------------|----------------|
| 1. Lift-arm chain | 3. Snapper pin |
| 2. Chain bracket  |                |

## Assembling the Reel Motors to the Cutting Units

- Apply a coat of clean grease to the splines of the reel-motor shaft.
- Apply a coat of oil the reel motor O-ring and install it onto the motor flange.
- Align the motor to the cutting unit so that the motor flanges clear the bolts clockwise (Figure 24).

**Important:** Make sure that the reel-motor cable is not twisted, kinked, or at risk of being pinched.

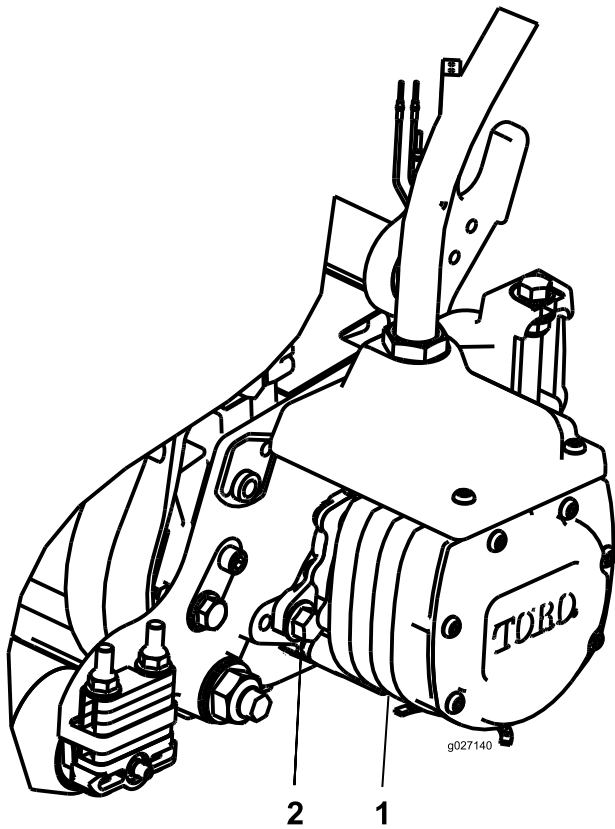

Figure 24

g027140

1. Reel-drive motor
2. Mounting bolt (2)

4. Rotate the motor counterclockwise until the flanges encircle the bolts.
5. Torque the mounting bolts to 19 to 25 N·m (14 to 18 ft-lb).
6. Repeat steps 1 through 5 at the other cutting units.

Use the following diagram to determine the positions of cutting units and reel motors.

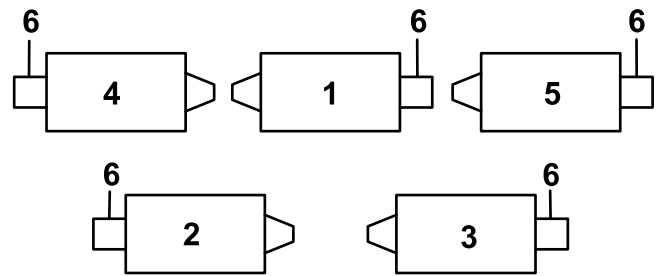

g316995

Figure 25

1. Center front cutting unit
2. Left rear cutting unit
3. Right rear cutting unit
4. Front left cutting unit
5. Front right cutting unit
6. Reel motor location

1. On the front left corner of the frame (#4 cutting unit location), remove the extra flange nut on the bolt securing the bulkhead bracket to the machine (Figure 26).
  2. Loosen the nuts on the finishing kit hose fitting, insert the hose into the slot on the bulkhead bracket and tighten the nuts.
- Note:** When tightening the nuts, use a backup wrench to prevent the hose from twisting or kinking.
3. Insert the connector plate onto the bulkhead-mounting bolts with the connectors positioned as shown in Figure 26.
  4. Secure the connector plate to 1 of the mounting bolts with the flange nut previously removed.
  5. Locate the wire harness on the machine and plug the wire connectors into the wire connectors of the finishing kit.

# 4

## Mounting the Finishing Kits

Parts needed for this procedure:

1	Finishing kit (sold separately)
---	---------------------------------

### Procedure

**Important:** To ensure that the electrical cable routing is appropriate and the cables are not twisted, mount the motors to the cutting units before mounting the finishing kits.

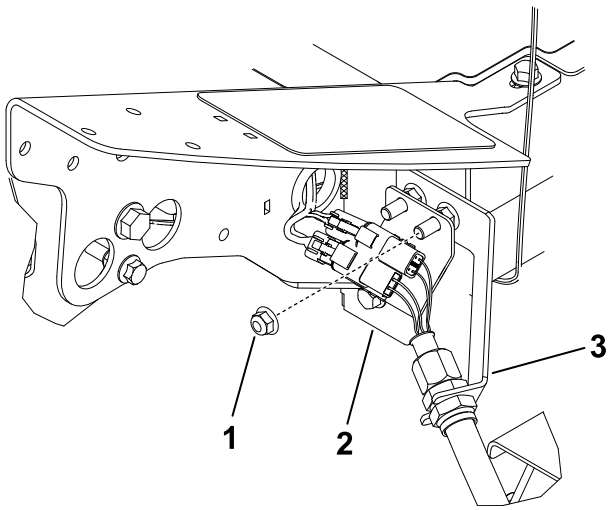

g316962

**Figure 26**  
Left front cutting unit (#4)

- 1. Extra flange nut
- 2. Connector plate
- 3. Bulkhead bracket

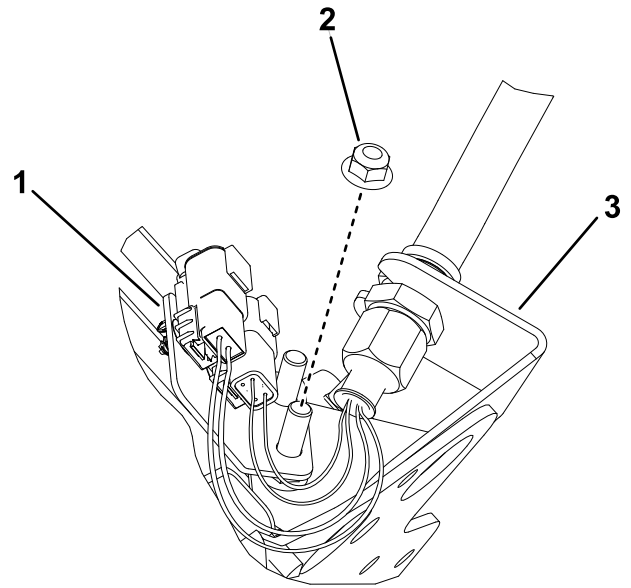

g316976

**Figure 28**  
Center front cutting unit (#1)  
(Underside of machine shown)

- 1. Connector plate
- 2. Extra flange nut
- 3. Bulkhead bracket

- 6. Repeat the procedure on the remaining 4 bulkhead locations as shown in [Figure 27](#) through [Figure 30](#).

**Important:** The connector plates are positioned differently at the remaining locations so the hose can be routed through the bulkhead bracket and to the cutting unit without getting twisted or kinked.

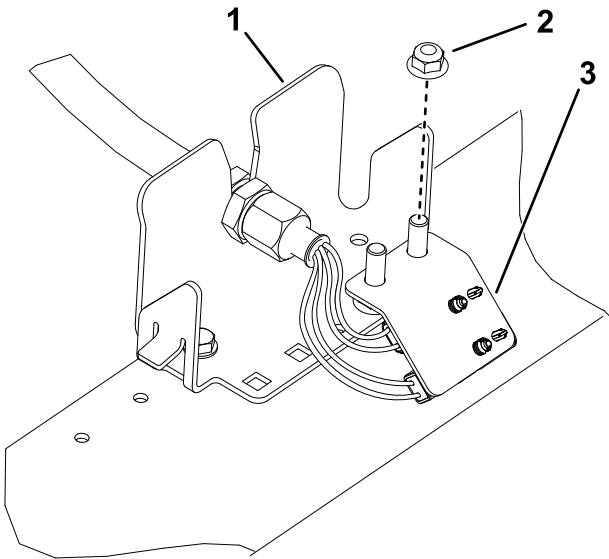

g316994

**Figure 27**  
Left rear cutting unit (#2)

- 1. Bulkhead bracket
- 2. Extra flange nut
- 3. Connector plate

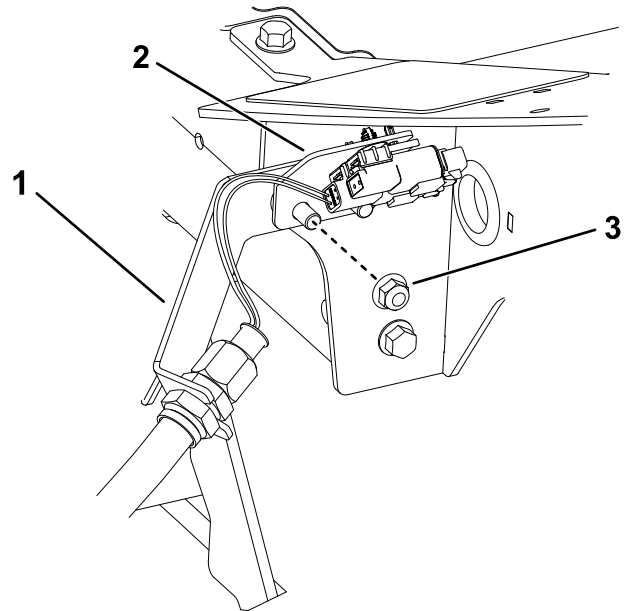

g316996

**Figure 29**  
Right front cutting unit location (#5)

- 1. Bulkhead bracket
- 2. Connector plate
- 3. Extra flange nut

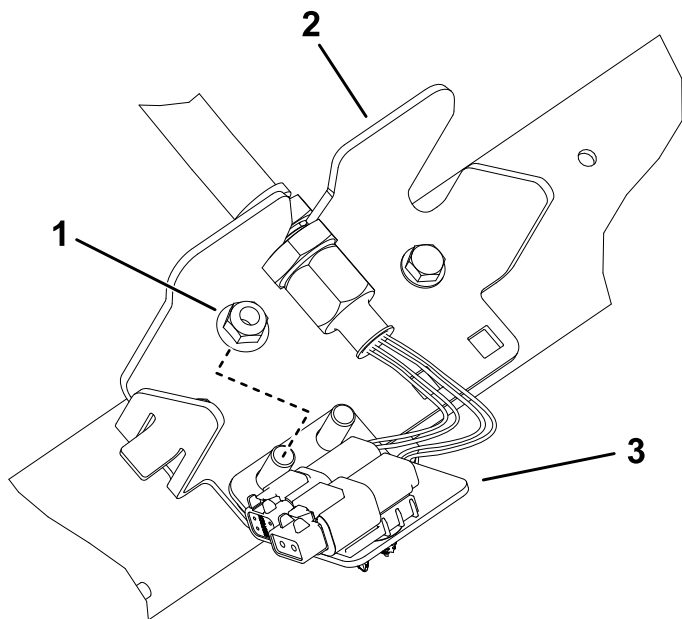
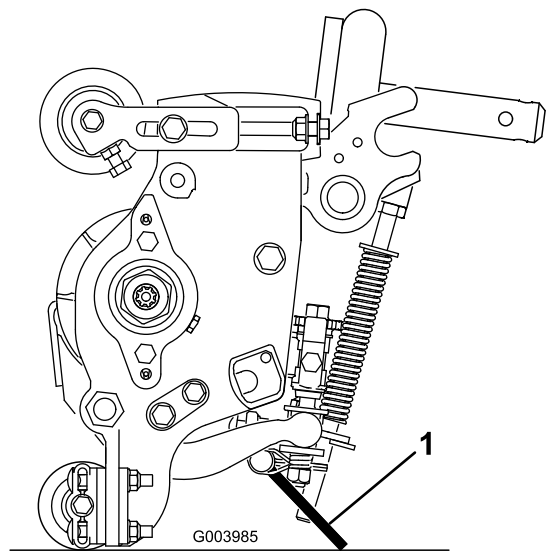

**Figure 30**

Right rear cutting unit (#3)

- 1. Extra flange nut
- 2. Bulkhead bracket
- 3. Connector plate

g316998



**Figure 31**

- 1. Cutting-unit kickstand

g003985

Secure the kickstand to the chain bracket with the snapper pin (Figure 32).

# 5

## Using the Cutting-Unit Kickstand

Parts needed for this procedure:

1	Cutting-unit kickstand
---	------------------------

### Procedure

Whenever you need to tip the cutting unit to expose the bedknife/reel, prop up the rear of the cutting unit with the kickstand to make sure that the nuts on the back end of the bedbar-adjusting screws are not resting on the work surface (Figure 31).

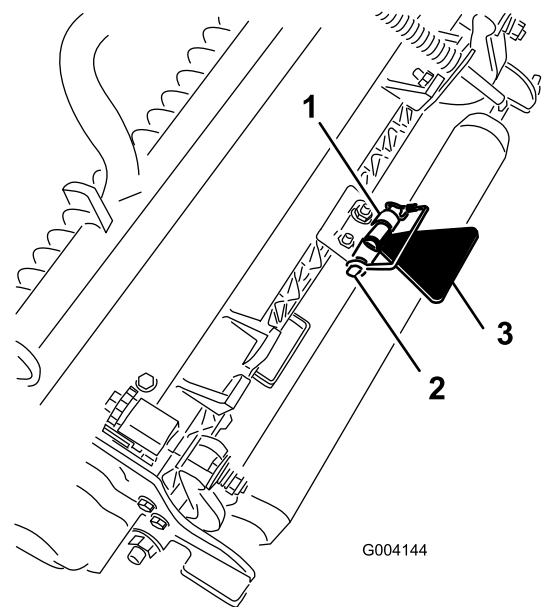

**Figure 32**

- 1. Chain bracket
- 2. Snapper pin
- 3. Cutting-unit kickstand

g004144

# 6

## Installing the 48 V Disconnect Jumper and Closing the Seat Base

No Parts Required

### Procedure

1. Apply dielectric grease to the contact surfaces of the battery disconnect jumper (Figure 33).

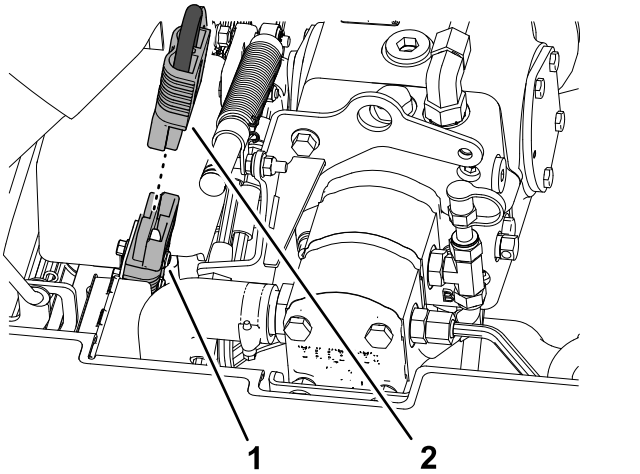

Figure 33

g353655

1. 48 V system connector
2. Battery disconnect jumper

2. Plug the battery disconnect jumper into the 48 V system connector.
3. Rotate the seat and seat base closed, and latch the base (Figure 34).

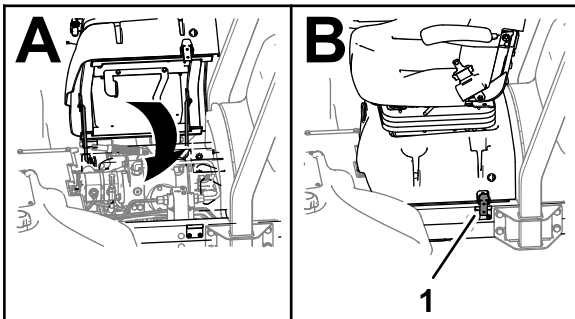

Figure 34

g379173

1. Latch (seat base)

# 7

## Installing the CE Hood Lock

Parts needed for this procedure:

1	Hood lock, seal, and jam nut
1	Washer

### Procedure

1. Unlatch and raise the hood.
2. Remove the rubber grommet from the hole in the left side of the hood (Figure 35).

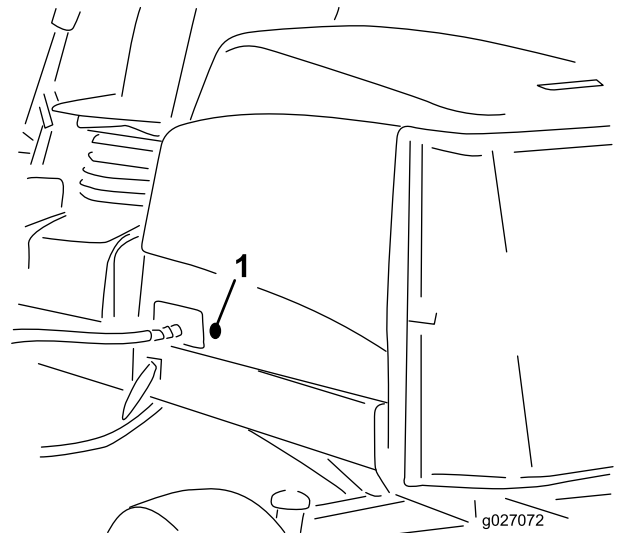
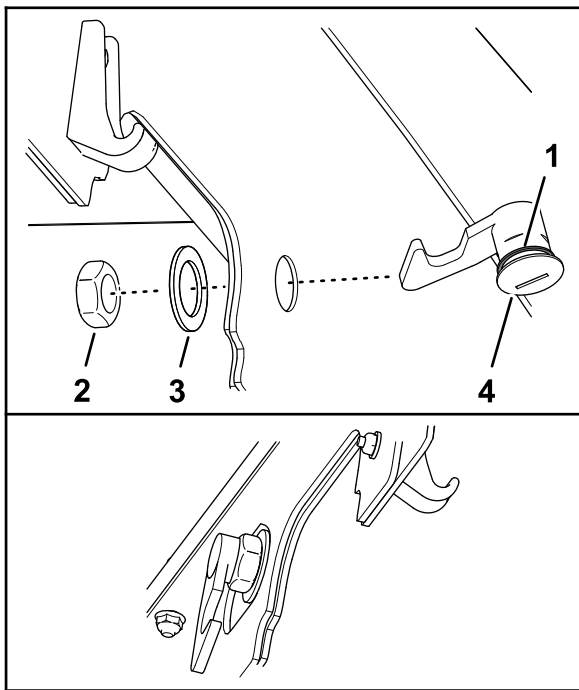

Figure 35

g027072

1. Rubber grommet

3. Ensure that the seal is assembled to the hood lock (Figure 36).



**Figure 36**

g375326

1. Hood latch
2. Nut
3. Seal
4. Washer

4. Remove the nut from the lock.
5. Outside the hood, insert the hook end of the latch through the hole in the hood.  
**Note:** The seal is aligned to the outside of the hood.
6. Inside the hood, Secure the lock to the hood with the washer and nut.
7. Close the hood, and use the enclosed hood-latch key to check that the hook of the lock engages the frame catch when locked.

# 8

## Applying the CE Decals

### Parts needed for this procedure:

1	CE decal
1	Production year decal
1	Warning decal

### Applying the CE Decal

1. Use rubbing alcohol and a clean rag to clean the area of the hood next to the hood lock, and allow the hood to dry. (Figure 37).

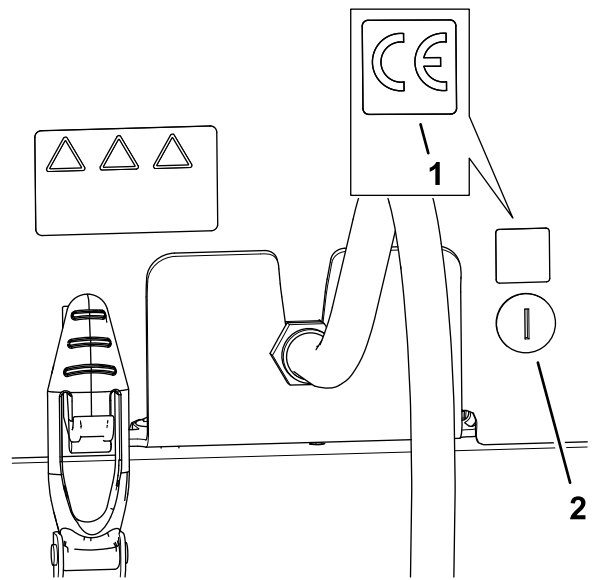

**Figure 37**

g375337

1. CE decal
2. Hood lock

2. Remove the backing from the CE decal.
3. Apply the decal to the hood.

## Applying the Year of Production Decal

1. Use rubbing alcohol and a clean rag to clean the floor bracket area next to the serial plate, and allow the bracket to dry (Figure 38).

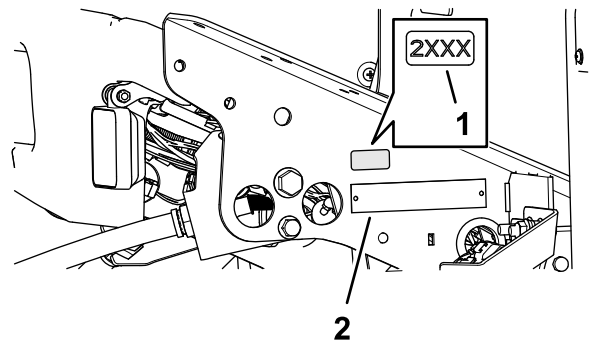

**Figure 38**

g375339

1. Year of production decal
2. Serial plate

2. Remove the backing from the year of production decal.
3. Apply the decal to the floor bracket.

## Applying the CE Warning Decal

1. Use rubbing alcohol and a clean rag to clean the surface of warning decal 133-2930, and allow the decal to dry (Figure 39).



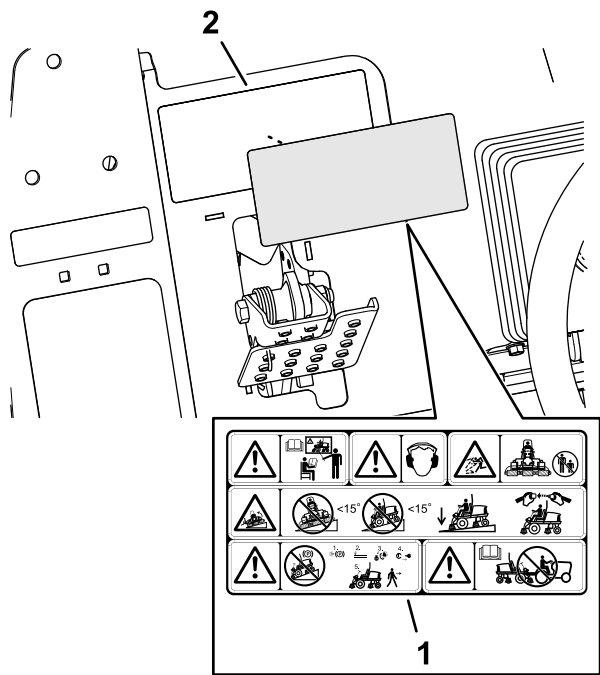

**Figure 39**

g375338

1. CE warning decal
2. Warning decal 133-2930

2. Remove the backing from the CE warning decal.
3. Apply the CE warning decal over decal 133-2930.

# Product Overview

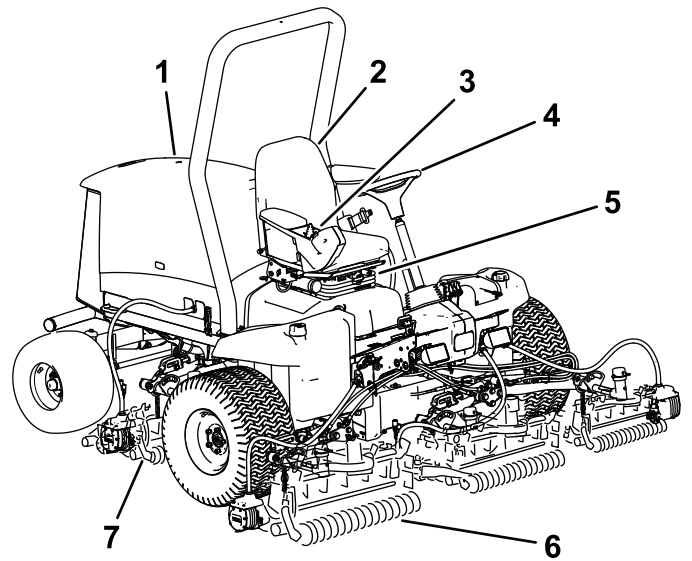

**Figure 40**

g260768

- |                    |                        |
|--------------------|------------------------|
| 1. Engine hood     | 5. Seat adjustments    |
| 2. Operator's seat | 6. Front cutting units |
| 3. Control arm     | 7. Rear cutting units  |
| 4. Steering wheel  |                        |

## Controls

### Traction Pedal

The traction pedal ([Figure 41](#)) controls the forward and reverse operation. Press the top of the pedal to move the machine forward and the bottom to move the machine backward. Ground speed depends on how far you press the pedal. For no load, maximum ground speed, fully press the pedal while the throttle is in the FAST position.

To stop the machine, reduce foot pressure on the traction pedal and allow it to return to the center position.

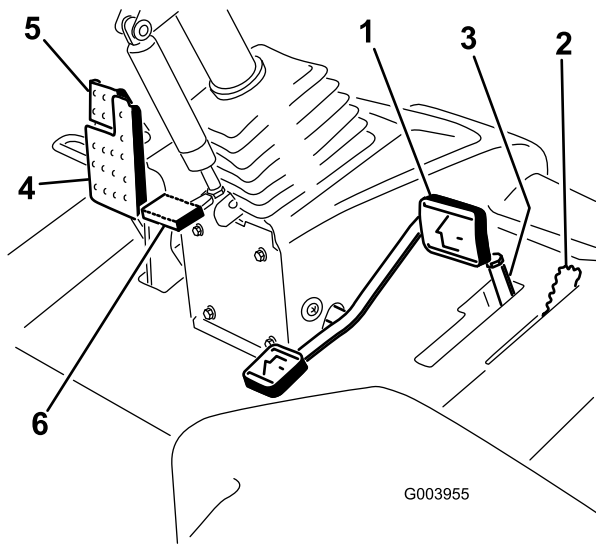

**Figure 41**

- |                                  |                        |
|----------------------------------|------------------------|
| 1. Traction pedal                | 4. Brake pedal         |
| 2. Mow/transport lever           | 5. Parking brake       |
| 3. Mow-speed limiter and spacers | 6. Tilt steering pedal |

## Mow/Transport Lever

Use the mow/transport lever (Figure 41) to put the machine into MOW mode or TRANSPORT mode. Push the lever forward to select the MOW mode, and backward to select the TRANSPORT mode.

**Note:** The cutting units cannot be lowered when the mow/transport lever is in the TRANSPORT position.

## Mow-Speed Limiter

When the mow-speed limiter (Figure 41) is flipped up/forward it limits the mow speed and allow the cutting units to be engaged. Each spacer adjusts the mowing speed by 0.8 km/h (0.5 mph). The more spacers there are on the top of the bolt, the slower the machine goes. Flip the mow speed limiter backward to allow maximum transport speed.

## Brake Pedal

Press the brake pedal (Figure 41) to stop the machine.

## Parking Brake

To engage the parking brake, (Figure 41) push down on the brake pedal and press the top forward to latch it. To release the parking brake, press the brake pedal until the parking-brake latch retracts.

## Tilt-Steering Pedal

To tilt the steering wheel towards you, press the foot pedal (Figure 41) down, pull the steering tower toward you to the most comfortable position, and release the pedal.

## Engine-Speed Switch

The engine-speed switch has 2 modes to change the engine speed (Figure 42). By momentarily tapping the switch, you can change the engine speed in 100 rpm increments. If you hold the switch down, the engine automatically moves to High or Low idle, depending on which end of the switch you press.

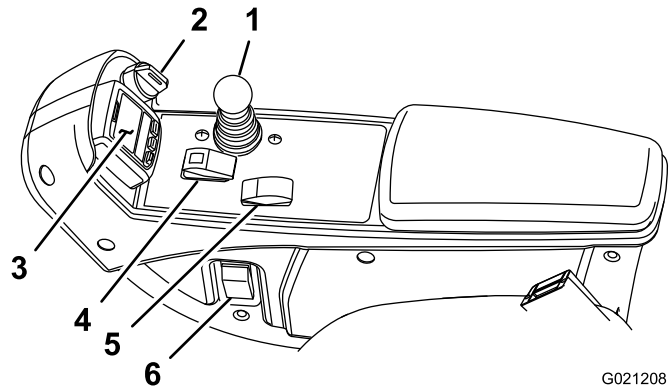

**Figure 42**

- |                                  |                                |
|----------------------------------|--------------------------------|
| 1. Lower mow/raise control lever | 4. Enable/disable switch lever |
| 2. Key switch                    | 5. Engine-speed switch         |
| 3. InfoCenter                    | 6. Headlight switch            |

## Lower Mow/Raise Control Lever

This lever (Figure 42) raises and lowers the cutting units and also starts and stops the cutting units when the cutting units are enabled in the MOW mode. You cannot lower the cutting units when the mow/transport lever is in the TRANSPORT position.

## Key Switch

The key switch (Figure 42) has 3 positions: OFF, ON/PREHEAT, and START.

## InfoCenter

The InfoCenter LCD display shows information about your machine, such as the operating status, various diagnostics, and other information about the machine (Figure 42).

## Enable/Disable Switch

Use the enable/disable switch (Figure 42) in conjunction with the lower mow/raise control lever to operate the cutting units.

## Headlight Switch

Pivot the switch downward to turn on the headlights (Figure 42).

## Power Point

The power point is a 12 V power supply for electronic devices (Figure 43).

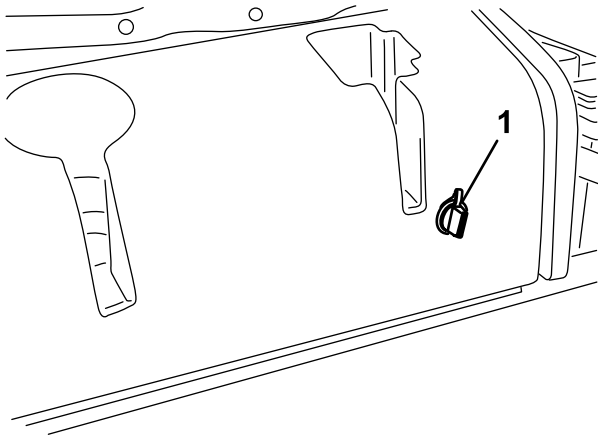

Figure 43

1. Power point

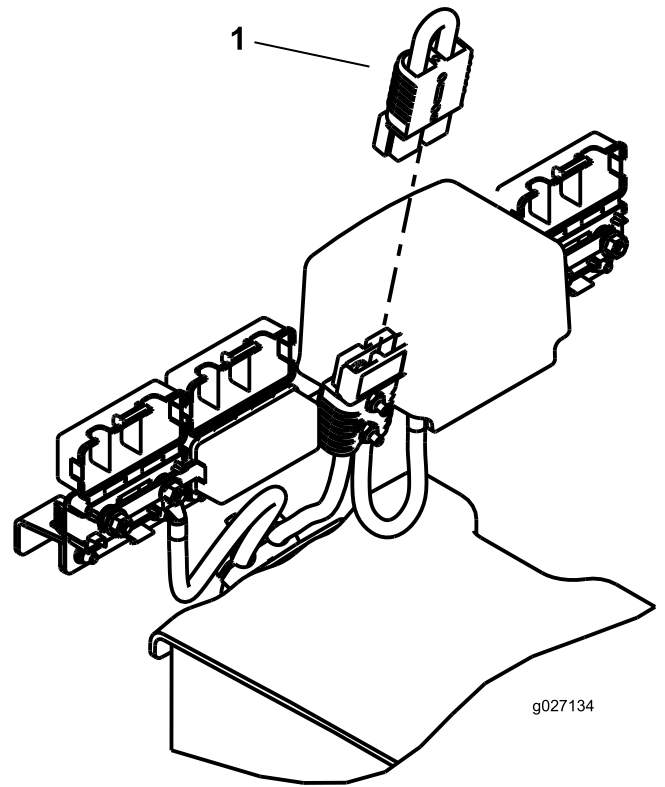

Figure 44

1. Power-disconnect connector

## ⚠ CAUTION

If you do not disconnect the power to the cutting units, someone could accidentally start the cutting unit, causing serious injury to hands and feet.

Always separate the cutting-unit-power-disconnect connectors before working on the cutting units.

## Cutting-Unit-Power Disconnect

Before installing, removing, or working on the cutting units, disconnect the cutting units from the power supply by separating the cutting-unit-power-disconnect connector (Figure 44), located under the seat. Plug the connector back in before operating the machine.

## Seat Controls

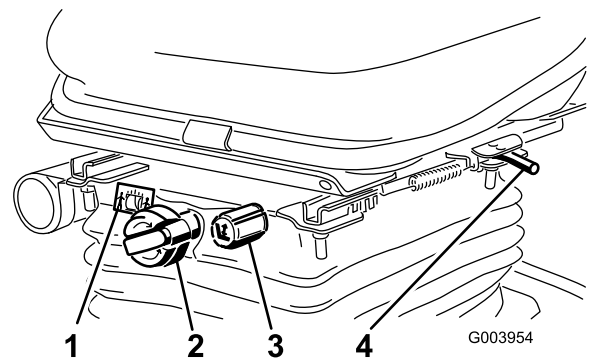

Figure 45

1. Weight gauge
2. Weight-adjusting knob
3. Height-adjusting knob
4. Adjusting lever

### Seat-Position Lever

Pull the seat-position lever (Figure 45) to move the seat forward and rearward. Release the lever to lock the seat position.

### Weight-Adjusting Knob

Rotate the weight-adjusting knob until your weight is displayed in the window of the weight gauge.

### Height-Adjusting Knob

Rotate the height-adjusting knob to change the height of the seat.

## Using the InfoCenter LCD Display

The InfoCenter LCD display shows information about your machine such as the operating status, various diagnostics and other information about the machine (Figure 46). There are multiple display screens on the InfoCenter. You can switch between the screens, at any time, by pressing any of the InfoCenter buttons and then selecting the appropriate directional arrow.

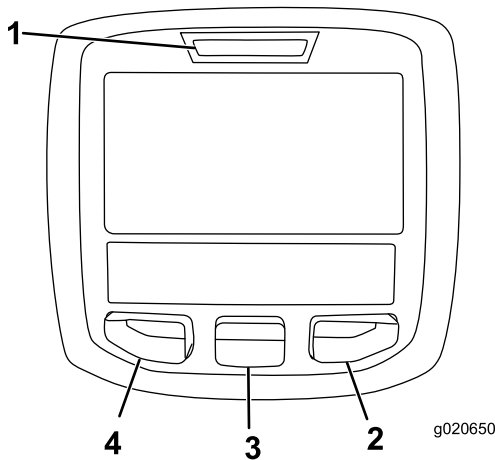

Figure 46

- 1. Indicator light
- 2. Right button
- 3. Middle button
- 4. Left button



















- Left Button, Menu Access/Back Button— Press this button to access the InfoCenter menus. You can use it to back out of any menu you are currently using.
- Middle Button— Press this button to scroll down menus.
- Right Button— Press this button to open a menu where a right arrow indicates additional content.

**Note:** The purpose of each button may change depending on what is required at the time. Each button is labeled with an icon displaying its current function.

## InfoCenter Icon Description

	Indicates when scheduled service should be performed
	Hour meter
	Info icon
	Fast
	Slow
	Fuel level
	The glow plugs are active.
	Raise the cutting units.
	Lower the cutting units.
	Sit in the seat.
	The parking brake is on.
	The range is high (transport).
	Neutral
	The range is low (mow).
	Engine-coolant temperature (°C or °F)
	Temperature (hot)
	The PTO is engaged.
	Not allowed
	Start the engine.
	Stop the engine.
	Engine
	Key switch

## InfoCenter Icon Description (cont'd.)

	Battery
	Motor/Generator (not charging)
	Motor/Generator (charging)
	E-Reel
	Front Backlap
	Rear Backlap
	The cutting units are lowering.
	The cutting units are raising.
<b>PIN</b>	PIN passcode
<b>CAN</b>	CAN bus
	InfoCenter
<b>Bad</b>	Bad or failed
	Bulb
<b>OUT</b>	Output of TEC controller or control wire in harness
	Switch
	Release the switch.
	Change to the indicated state.
Symbols are often combined to form sentences. Some examples are shown below	
	Put the machine into Neutral.
	Engine start is denied.
	Engine shutdown
	Engine coolant is too hot.
	Sit down or set parking brake

## Using the Menu

To access the InfoCenter menu system, press the menu access button while at the main screen. This brings you to the main menu. Refer to the following tables for a synopsis of the options available from the menus:

Main Menu	
Menu Item	Description
Faults	The Faults menu contains a list of the recent machine faults. Refer to the <i>Service Manual</i> or contact your Toro Distributor for more information on the Faults menu and the information contained there.
Service	The Service menu contains information on the machine such as hours of use, counters, and other similar numbers.
Diagnostics	The Diagnostics menu displays the state of each machine switch, sensor, and control output. You can use this to troubleshoot certain issues as it quickly tells you which machine controls are on and which are off.
Settings	The Settings menu allows you to customize and modify configuration variables on the InfoCenter display.
About	The About menu lists the model number, serial number, and software version of your machine.

Service	
Menu Item	Description
Hours	Lists the total number of hours that the machine, engine and PTO have been on, as well as the number of hours the machine has been transported and service due.
Counts	Lists numerous counts the machine has experienced.

Diagnostics	
Menu Item	Description
Cutting Units	Indicates the inputs, qualifiers, and outputs for raising and lowering the cutting units.
Hi/Low Range	Indicates the inputs, qualifiers, and outputs for driving in transport mode.
PTO	Indicates the inputs, qualifiers, and outputs for enabling the PTO circuit.

Engine Run	Indicates the inputs, qualifiers, and outputs for starting the engine.
Backlap	Indicates the inputs, qualifiers and outputs for operating the backlap function.

Settings	
Menu Item	Description
Units	Controls the units used on the InfoCenter. The menu choices are English or Metric.
Language	Controls the language used on the InfoCenter*.
LCD Backlight	Controls the brightness of the LCD display.
LCD Contrast	Controls the contrast of the LCD display.
Front Backlap Reel Speed	Controls the speed of the front reels in backlap mode.
Rear Backlap Reel Speed	Controls the speed of the rear reels in backlap mode.
Protected Menu	Allows the superintendent/mechanic to access protected menus by inputting a passcode.
Auto Idle	Controls the amount of time allowed before returning the engine to low idle when the machine is stationary.
Blade Count	Controls the number of blades on the reel for reel speed.
Mow Speed	Controls the ground speed for determining the reel speed.
Height of cut (HOC)	Controls the height of cut (HOC) for determining the reel speed.
F Reel RPM	Displays the calculated reel speed position for the front reels. The reels can also be manually adjusted.
R Reel RPM	Displays the calculated reel speed position for the rear reels. The reels can also be manually adjusted.
Economy Mode	When activated, the Economy Mode lowers the engine speed while mowing to reduce noise and fuel consumption. The reel speed does not change, but the mow speed is decreased if the mow stop is not adjusted accordingly.

\*Only "operator-faced" text is translated. Faults, Service, and Diagnostics screens are "service-faced." Titles are in the selected language, but menu items are in English.

About	
Menu Item	Description
Model	Lists the model number of the machine.
SN	Lists the serial number of the machine.
Machine Controller Revision	Lists the software revision of the master controller.
CU 1 CU 2 CU 3 CU 4 CU 5	Lists the software revision of each cutting unit.
Generator	Lists the software revision of the motor/generator.
InfoCenter Revision	Lists the software revision of the InfoCenter.
CAN Bus	Lists the machine communication bus status.

## Protected Menu

There are 2 additional display screens and 7 operating configuration settings that are adjustable within the Settings Menu of the InfoCenter: Auto Idle, Blade Count, Mow Speed, Height of Cut (HOC), F Reel RPM, R Reel RPM, and Economy Mode. These settings can be locked by using the Protected Menu.

**Note:** At the time of delivery, the initial password code is programmed by your distributor.

## Accessing Protected Menus

**Note:** The factory default PIN code for you machine is either 0000 or 1234.

If you changed the PIN code and forgot the code, contact your authorized Toro distributor for assistance.

1. From the MAIN MENU, use the center button to scroll down to the SETTINGS MENU and press the right button (Figure 47).

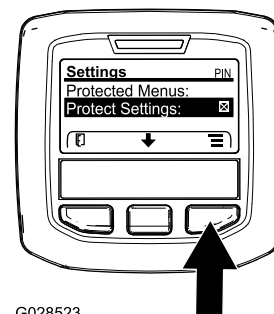

G028523

Figure 47

g028523



- In the SETTINGS MENU, use the center button to scroll down to the PROTECTED MENU and press the right button (Figure 48A).

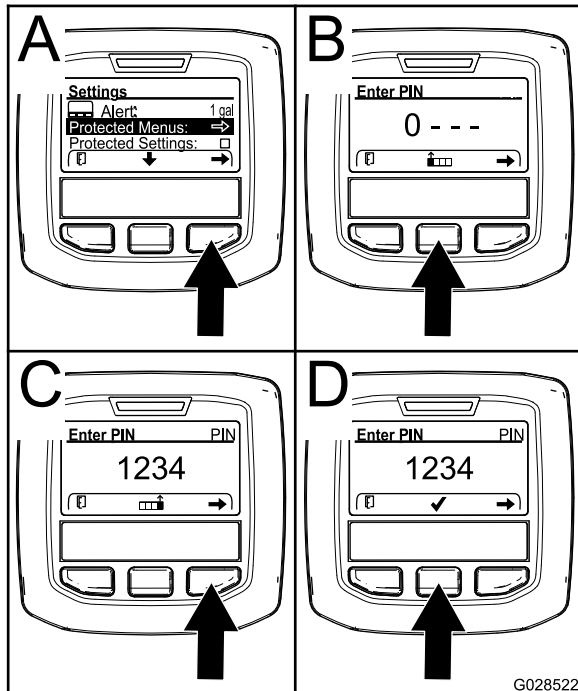

Figure 48

- To enter the PIN code, press the center button until the correct first digit appears, then press the right button to move on to the next digit (Figure 48B and Figure 48C). Repeat this step until the last digit is entered and press the right button once more.
- Press the middle button to enter the PIN code (Figure 48D).

Wait until the red indicator light of the InfoCenter illuminates.

**Note:** If the InfoCenter accepts the PIN code and the protected menu is unlocked, the word “PIN” displays in the upper right corner of the screen.

**Note:** Rotate the key switch to the OFF position and then to the ON position locks the protected menu.

You can view and change the settings in the Protected Menu. Once you access the Protected Menu, scroll down to Protect Settings option. Use the right button to change the setting. Setting the Protect Settings to OFF allows you to view and change the settings in the Protected Menu without entering the PIN code. Setting the Protect Settings to ON hides the protected options and requires you to enter the PIN code to change the setting in the Protected Menu. After you set the PIN code, rotate the key switch OFF and back to the ON position to enable and save this feature.

## Setting the Service Due Timer

The service due timer resets the service due hours after a scheduled maintenance procedure is performed.

- In the Settings Menu, use the center button to scroll down to the PROTECTED MENU and press the right button.
- Enter PIN; refer to Accessing Protected Menus on the *Operator's Manual* for your machine.
- In the Service Menu, navigate to the HOURS MENU.
- Scroll down to the service symbol

**Note:** If service is currently due, the first icon shows NOW.

- Below the first icon is the service interval item (time interval, e.g. 250, 500, etc.)

**Note:** Service interval is a protected menu item.

- Highlight the service interval and press the right button.
- When the new screen appears, confirm RESET SERVICE HOURS—ARE YOU SURE?
- Select YES(center button) or NO (left button).
- After you select YES the interval screen clears, and reverts back to the Service Hours selections.

## Setting the Auto Idle

- In the Settings Menu, scroll down to Auto Idle.
- Press the right button to change the auto idle time between OFF, 8S, 10S, 15S, 20S, and 30S.

## Setting the Blade Count

- In the Settings Menu, scroll down to Blade Count
- Press the right button to change the blade count between 5, 8 or 11 blade reels.

## Setting the Mow Speed

- In the Settings Menu, scroll down to Mow Speed.
- Press the right button to select Mow Speed.
- Use the center and right button to select the appropriate mow speed set on the mechanical mow-speed limiter on the traction pedal.
- Press the left button to exit mow speed and save the setting.

## Setting the Height of Cut (HOC)

- In the Settings Menu, scroll down to HOC.
- Press the right button to select HOC.

- Use the center and right button to select the appropriate HOC setting. (If the exact setting is not displayed, select the nearest HOC setting from the list displayed).
- Press the left button to exit HOC and save the setting.

## Setting the Front and Rear Reel Speeds

Although the front and rear reel speeds are calculated by inputting the number of blades, mow speed and HOC into the InfoCenter, the setting can be manually changed to accommodate for different mowing conditions.

- To change the Reel Speed Settings, scroll down to the F Reel RPM, R Reel RPM, or both.
- Press the right button to change the reel speed value. As the speed setting is changed, the display continues to show the calculated reel speed based on blade count, mow speed and HOC which was previously entered, but the new value also is displayed.

## Setting the Economy Mode

- From the Main Menu, use the center button to scroll down to the Settings Menu.
- Press the right button to select.
- In the Settings Menu, use the center button to scroll down to the Economy Mode.
- Press the right button to select the ON function.
- Press the left button to save the setting and exit the settings.

## To Access Protected Display Screens

From the main screen, press the center button once, when the arrows appear above the buttons, press the center button again to scroll through the display screens.

Press the center button again to access the eReel information screen displaying the reel current and the speed for each of the 5 cutting units.

Press the center button again to access the energy mode screen displaying the components, energy flow and the direction while in operation.

## Specifications

**Note:** Specifications and design are subject to change without notice.

Transport Width	228 cm (90 inches)
Width of cut	254 cm (100 inches)
Length	282 cm (111 inches)
Height w/ ROPS	160 cm (63 inches)
Weight	1259 kg (2,776 lb)
Engine	Kubota 24.8 hp
Fuel tank capacity	53 L (14 US gallons)
Transport speed	0 to 16 km/h (0 to 10 mph)
Mowing speed	0 to 13 km/h (0 to 8 mph)

## Attachments/Accessories

A selection of Toro approved attachments and accessories is available for use with the machine to enhance and expand its capabilities. Contact your Authorized Service Dealer or authorized Toro distributor or go to [www.Toro.com](http://www.Toro.com) for a list of all approved attachments and accessories.

To ensure optimum performance and continued safety certification of the machine, use only genuine Toro replacement parts and accessories. Replacement parts and accessories made by other manufacturers could be dangerous, and such use could void the product warranty.

# Operation

**Note:** Determine the left and right sides of the machine from the normal operating position.

## Before Operation

### Before Operation Safety

#### General Safety

- Never allow children or untrained people to operate or service the machine. Local regulations may restrict the age of the operator. The owner is responsible for training all operators and mechanics.
- Become familiar with the safe operation of the equipment, operator controls, and safety signs.
- Before you leave the operator's position, do the following:
  - Park the machine on a level surface.
  - Disengage and lower the cutting units.
  - Engage the parking brake.
  - Shut off the engine and remove the key.
  - Wait for all movement to stop.
  - Allow the machine to cool before adjusting, servicing, cleaning, or storing it.
- Know how to stop the machine and shut off the engine quickly.
- Do not operate the machine without all guards and other safety protective devices in place and functioning properly on the machine.
- Before mowing, always inspect the machine to ensure that the cutting units are in good working condition.
- Inspect the area where you will use the machine and remove all objects that the machine could throw.

#### Fuel Safety

- Use extreme care in handling fuel. It is flammable and its vapors are explosive.
- Extinguish all cigarettes, cigars, pipes, and other sources of ignition.
- Use only an approved fuel container.
- Do not remove the fuel cap or fill the fuel tank while the engine is running or hot.
- Do not add or drain fuel in an enclosed space.

- Do not store the machine or fuel container where there is an open flame, spark, or pilot light, such as on a water heater or other appliance.
- If you spill fuel, do not attempt to start the engine; avoid creating any source of ignition until the fuel vapors have dissipated.

### Fuel Specification

Use only clean, fresh diesel fuel or biodiesel fuels with low (<500 ppm) or ultra low (<15 ppm) sulfur content. The minimum cetane rating should be 40. Purchase fuel in quantities that can be used within 180 days to ensure fuel freshness.

Use summer grade diesel fuel (No. 2-D) at temperatures above -7°C (20°F) and winter grade (No. 1-D or No. 1-D/2-D blend) below that temperature. Use of winter grade fuel at lower temperatures provides lower flash point and cold flow characteristics which eases starting and reduces fuel filter plugging.

Use of summer grade fuel above -7°C (20°F) contributes toward longer fuel pump life and increased power compared to winter grade fuel.

**Important:** Do not use kerosene or gasoline instead of diesel fuel. Failure to observe this caution damages the engine.

#### Biodiesel Ready

This machine can also use a biodiesel blended fuel of up to B20 (20% biodiesel, 80% petrodiesel). The petrodiesel portion should be low or ultra low sulfur. Observe the following precautions:

- The biodiesel portion of the fuel must meet specification ASTM D6751 or EN14214.
- The blended fuel composition should meet ASTM D975 or EN590.
- Painted surfaces may be damaged by biodiesel blends.
- Use B5 (biodiesel content of 5%) or lesser blends in cold weather.
- Monitor seals, hoses, gaskets in contact with fuel as they may be degraded over time.
- Fuel filter plugging may be expected for a time after converting to biodiesel blended.
- Contact your distributor if you wish for more information on biodiesel.

### Fuel Tank Capacity

53 L (14 US gallons)

# Adding Fuel

1. Park the machine on a level surface, lower the cutting units, shut off the engine, and remove the key.
2. Using a clean rag, clean the area around the fuel-tank cap.
3. Remove the cap from the fuel tank (Figure 49).

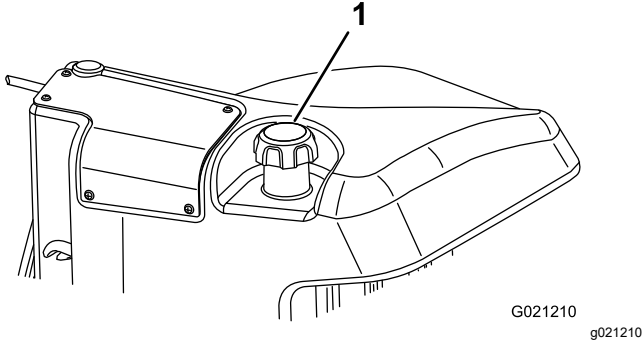

Figure 49

1. Fuel-tank cap

4. Fill the tank until the level is to the bottom of the filler neck with diesel fuel.
5. Install fuel-tank cap tightly after filling tank.

**Note:** If possible, fill the fuel tank after each use. This minimizes possible buildup of condensation inside the fuel tank.

# Performing Daily Maintenance

**Service Interval:** Before each use or daily

Before starting the machine each day, perform the Each Use/Daily procedures listed in [Maintenance \(page 39\)](#).

# Checking the Interlock Switches

**Service Interval:** Before each use or daily

## ⚠ CAUTION

If safety interlock switches are disconnected or damaged, the machine could operate unexpectedly, causing personal injury.

- Do not tamper with the interlock switches.
- Check the operation of the interlock switches daily and replace any damaged switches before operating the machine.

**Important:** If your machine fails any of the interlock switch checks, contact your authorized Toro distributor.

# Preparing the Machine

1. Drive the machine slowly to an open area.
2. Lower the cutting units, shut off the engine, and engage the parking brake.

# Checking the Traction Pedal Start-Interlock

1. Sit in the operator's seat.
2. Engage the parking brake.
3. Press the PTO switch to the DISENGAGE position.
4. Press the traction pedal.
5. Rotate the key to the START position.

**Note:** The starter should not crank the engine with the traction pedal pressed.

# Checking the PTO-Start Interlock

1. Sit in the operator's seat.
2. Press the PTO switch to the ENGAGE position.
3. Start the engine.

**Note:** The engine should not start with the PTO switch in the ENGAGE position.

# Checking the PTO-Run Interlock

1. Sit in the operator's seat.
2. Press the PTO switch to the DISENGAGE position.
3. Start the engine.
4. Rise from the seat.
5. Press the PTO switch to the ENGAGE position.

**Note:** The PTO should not run when you are out of the operator's seat.

# Checking the Parking Brake and Traction Pedal Run-Interlock

1. Sit in the operator's seat.
2. Engage the parking brake.
3. Press the PTO switch to the DISENGAGE position.
4. Keep your foot off the traction pedal.
5. Start the engine.
6. Press the traction pedal.

**Note:** The engine should shut off when the parking brake is engaged and the traction pedal is pressed.

# Breaking in the Machine

To ensure optimum performance of the parking brake system, burnish (break in) the brakes before use. Set the forward traction speed to 6.4 km/h (4 mph) to match the reverse traction speed (all 8 spacers moved to the top of the mow-speed control). With the engine at high idle, proceed forward with the mow-speed-control stop engaged and ride the brake for 15 seconds. Proceed backward at full reverse speed and ride the brake for 15 seconds. Repeat this 5 times waiting 1 minute between each forward and reverse cycle to avoid overheating the brakes. An adjustment to the brakes may be required after break-in; refer to [Maintenance \(page 39\)](#).

## *During Operation*

## During Operation Safety

### General Safety

- The owner/operator can prevent and is responsible for accidents that may cause personal injury or property damage.
- Wear appropriate clothing, including eye protection; long pants; substantial, slip-resistant footwear; and hearing protection. Tie back long hair and do not wear loose clothing or loose jewelry.
- Do not operate the machine while ill, tired, or under the influence of alcohol or drugs.
- Use your full attention while operating the machine. Do not engage in any activity that causes distractions; otherwise, injury or property damage may occur.
- Before you start the engine, ensure that all drives are in neutral, the parking brake is engaged, and you are in the operating position.
- Do not carry passengers on the machine and keep bystanders and children out of the operating area.
- Operate the machine only in good visibility to avoid holes or hidden hazards.
- Avoid mowing on wet grass. Reduced traction could cause the machine to slide.
- Keep your hands and feet away from the cutting units.
- Look behind and down before backing up to be sure of a clear path.
- Use care when approaching blind corners, shrubs, trees, or other objects that may obscure your vision.
- Stop the cutting units whenever you are not mowing.

- Slow down and use caution when making turns and crossing roads and sidewalks with the machine. Always yield the right-of-way.
- Operate the engine only in well-ventilated areas. Exhaust gases contain carbon monoxide, which is lethal if inhaled.
- Do not leave a running machine unattended.
- Before you leave the operator's position, do the following:
  - Park the machine on a level surface.
  - Disengage and lower the cutting units.
  - Engage the parking brake.
  - Shut off the engine and remove the key.
  - Wait for all movement to stop.
  - Allow the machine to cool before adjusting, servicing, cleaning, or storing it.
- Operate the machine only in good visibility and appropriate weather conditions. Do not operate the machine when there is the risk of lightning.

### Rollover Protection System (ROPS) Safety

- Do not remove any of the ROPS components from the machine.
- Ensure that the seat belt is attached and that you can release it quickly in an emergency.
- Always wear your seat belt.
- Check carefully for overhead obstructions and do not contact them.
- Keep the ROPS in safe operating condition by thoroughly inspecting it periodically for damage and keeping all the mounting fasteners tight.
- Replace all damaged ROPS components. Do not repair or alter them.

### Slope Safety

- Slopes are a major factor related to loss of control and rollover accidents, which can result in severe injury or death. You are responsible for safe slope operation. Operating the machine on any slope requires extra caution.
- Evaluate the site conditions to determine if the slope is safe for machine operation, including surveying the site. Always use common sense and good judgment when performing this survey.
- Review the slope instructions, listed below, for operating the machine on slopes. Before you operate the machine, review the site conditions to determine whether you can operate the machine in the conditions on that day and at that site.



Changes in the terrain can result in a change in slope operation for the machine.

- Avoid starting, stopping, or turning the machine on slopes. Avoid making sudden changes in speed or direction. Make turns slowly and gradually.
- Do not operate a machine under any conditions where traction, steering, or stability is in question.
- Remove or mark obstructions such as ditches, holes, ruts, bumps, rocks, or other hidden hazards. Tall grass can hide obstructions. Uneven terrain could overturn the machine.
- Be aware that operating the machine on wet grass, across slopes, or downhill may cause the machine to lose traction.
- Use extreme caution when operating the machine near drop-offs, ditches, embankments, water hazards, or other hazards. The machine could suddenly roll over if a wheel goes over the edge or the edge caves in. Establish a safety area between the machine and any hazard.
- Identify hazards at the base of the slope. If there are hazards, mow the slope with a pedestrian-controlled machine.
- If possible, keep the cutting units lowered to the ground while operating on slopes. Raising the cutting units while operating on slopes can cause the machine to become unstable.

## Starting the Engine

**Important:** You must bleed the fuel system before starting the engine if you are starting the engine for the first time, the engine has shut off due to lack of fuel, or you have performed maintenance on the fuel system; refer to [Bleeding the Fuel System](#) (page 53).

1. Sit on the seat, keep your foot off the traction pedal so that it is in NEUTRAL, engage the parking brake, set the engine-speed switch to the FAST position, and ensure that the Enable/Disable switch is in the DISABLE position.
2. Turn the key to the ON/PREHEAT position.  
An automatic timer controls the glow plug preheat for 6 seconds.
3. After preheating the glow plugs, turn the key to the START position.

Crank the engine for no longer than 15 seconds. Release the key when the engine starts. If additional preheating is required, turn the key to the OFF position and then to the ON/PREHEAT position. Repeat this process as required.

4. Run the engine at low idle speed until it warms up.

## Shutting Off the Engine

1. Move all controls to NEUTRAL, engage the parking brake, move the throttle to the LOW IDLE position and allow the engine to reach low idle speed.

**Important:** Allow the engine to idle for 5 minutes before shutting it off after a full load operation. Failure to do so may lead to trouble on a turbo-charged engine.

2. Turn the key to the OFF position and remove it from the switch.

## Adjusting the Turf-Compensation Spring

The turf-compensation spring ([Figure 50](#)) transfers the weight from the front roller to the rear roller. This helps to reduce a wave pattern in the turf, also known as marcelling or bobbing.

**Important:** Make spring adjustments with the cutting unit mounted to the traction unit, pointing straight ahead, and lowered to the shop floor.

1. Make sure that the hairpin is installed in the rear hole in the spring rod ([Figure 50](#)).

**Note:** When servicing the cutting unit, move the hairpin to the spring-rod hole next to the turf-compensation spring.

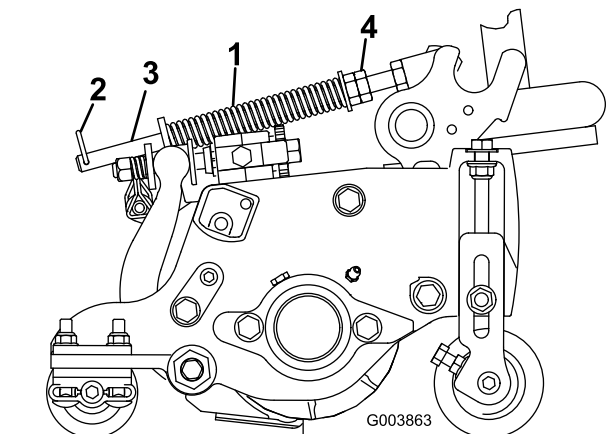

**Figure 50**

- |                             |               |
|-----------------------------|---------------|
| 1. Turf-compensation spring | 3. Spring rod |
| 2. Hairpin                  | 4. Hex nuts   |

2. Tighten the hex nuts on the front end of the spring rod until the compressed length of the spring is 15.9 cm (6.25 inches); refer to [Figure 50](#).

**Note:** When operating on rough terrain decrease the spring length by 13 mm (1/2 inch). Ground following will be slightly decreased.

**Note:** The turf compensation setting will need to be reset if the HOC setting or the Aggressiveness of Cut setting is changed.

## Adjusting the Lift-Arm Counterbalance Rear Cutting Units

### ⚠ CAUTION

The springs are under tension and could cause personal injury.

Use caution when adjusting the springs.

You can adjust the amount of counterbalance force applied to the rear cutting-units to help compensate for different turf conditions, and to maintain a uniform height of cut in rough conditions or in areas of thatch buildup.

You adjust counterbalance force of each torsion spring to 1 of 4 settings. Each increment increases or decreases the counterbalance force on the cutting unit by 2.3 kg (5 lb). You can position the springs at the back side of the first spring actuator to remove all counterbalance (fourth position).

**Note:** To remove all counterbalance force, position the long leg of the torsion spring above the shouldered stud.

1. Park the machine on a level surface, lower the cutting units, shut off the engine, engage the parking brake, and remove the key.
2. Insert the long end of the counterbalance spring into a tube or similar object, and pivot the spring around the shouldered stud to the desired position (Figure 51).

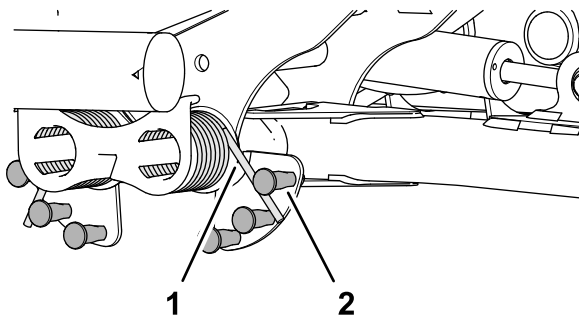

Figure 51

g375585

1. Spring
2. Shouldered stud

3. Repeat steps 1 and 2 at the other counterbalance spring.

## Adjusting the Lift-Arm Turnaround Position

1. Park the machine on a level surface, lower the cutting units, shut off the engine, engage the parking brake, and remove the key.
2. The lift-arm switch is located underneath the hydraulic tank and inboard of the cutting unit #5 lift arm (Figure 23).

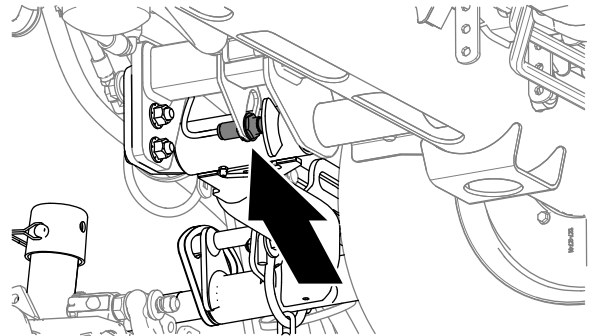

g375697

Figure 52

3. Loosen the jam nut that secures lift-arm switch to the switch plate (Figure 53).

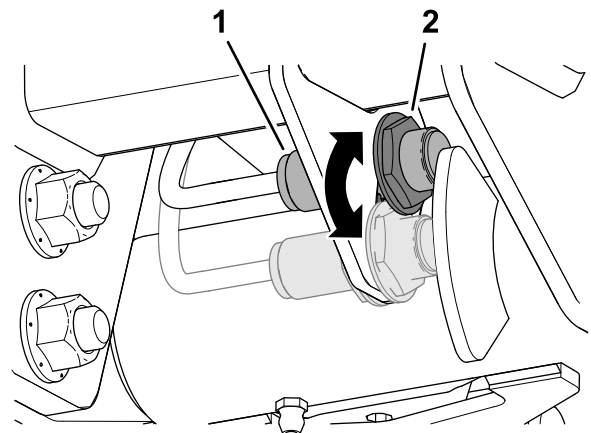

g375696

Figure 53

1. Switch
2. Lift-arm sensing device

4. Adjust the lift-arm switch as follows:
  - To increase the lift-arm turnaround height, move the switch down.
  - To decrease the lift-arm turnaround height, move the switch up.
5. Tighten the jam nut.

# Setting the Reel Speed

To achieve a consistent, high quality-of-cut and a uniform after cut appearance, it is important that you set the reel speed to the proper setting. Adjust the reel speed as follows:

1. In the InfoCenter, under the settings menu, enter the blade count, mow speed, and HOC to calculate the proper reel speed.
2. If further adjustments are required, in the settings menu, scroll down to the F Reel RPM, R Reel RPM, or both.
3. Press the right button to change the reel speed value. As the speed setting is changed, the display continues to show the calculated reel speed based on blade count, mow speed, and HOC, but the new value is also displayed.

**Note:** The reel speed may need to be increased or decreased to compensate for varying turf conditions.

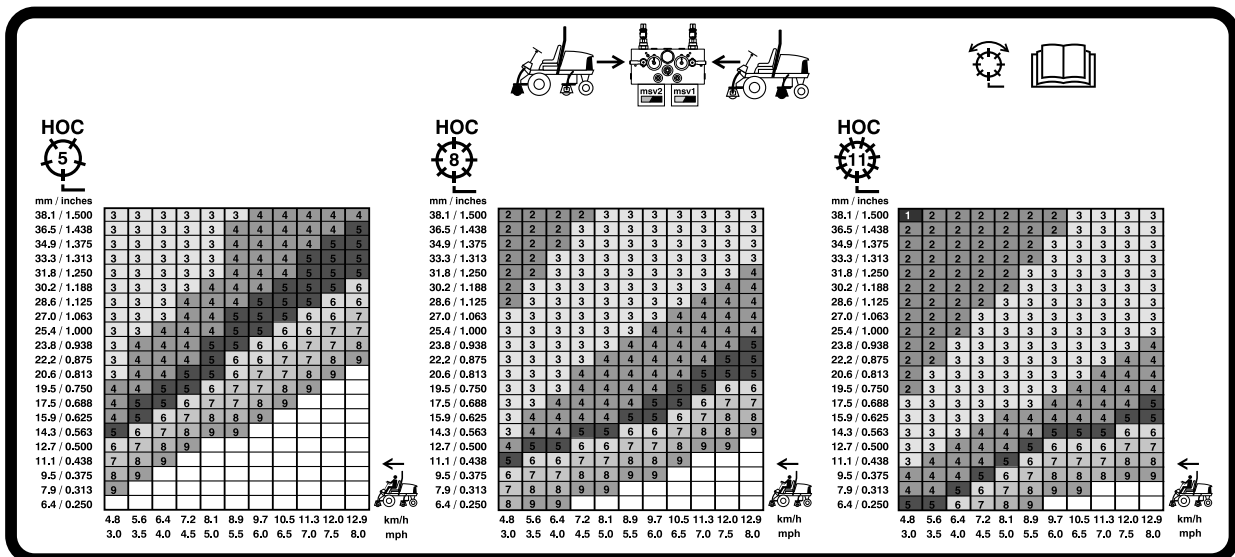

G031995

g031995

Figure 54

5 inch (127 mm) Reel Speed Chart

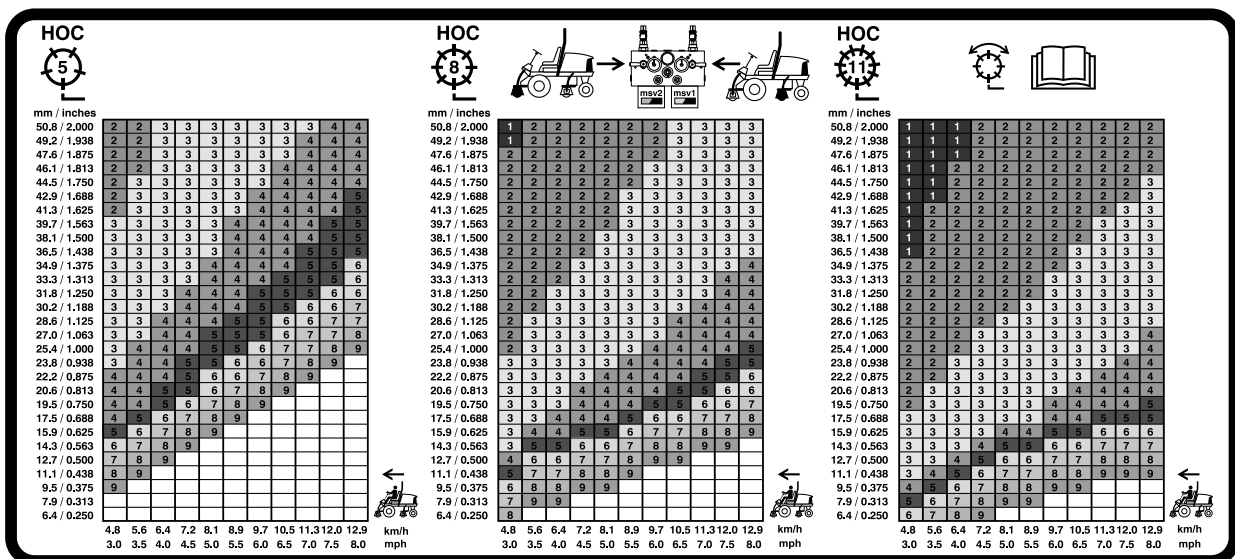

G031996

g031996

Figure 55

7 inch (178 mm) Reel Speed Chart



# Understanding the Diagnostic Light

The machine is equipped with a diagnostic light which indicates if the electronic controller senses an electronic malfunction. The diagnostic light is located on the InfoCenter, above the display screen (Figure 56). When the machine is functioning properly and the key switch is moved to the ON/RUN position, the diagnostic light turns on briefly to indicate the light is working properly. When a machine advisory message is displayed, the light illuminates when the message is present. When a fault message is displayed, the light blinks until the fault is resolved.

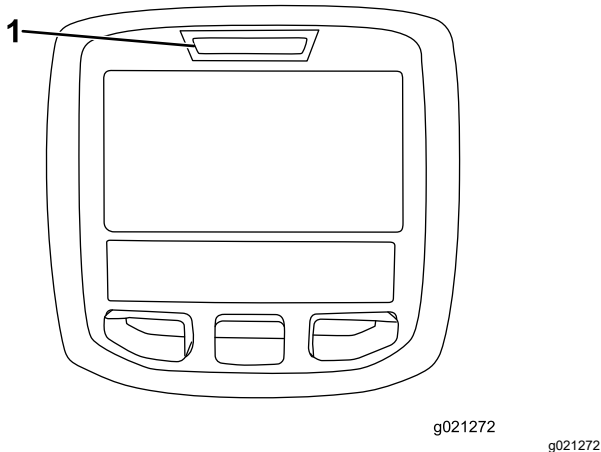

Figure 56

1. Diagnostic light

## Operating Tips

### Becoming Familiarized with the Machine

Before mowing grass, practice operating the machine in an open area. Start and shut off the engine. Operate in forward and reverse. Lower and raise the cutting units and engage and disengage the reels. When you feel familiar with the machine, practice operating up and down slopes at different speeds.

### Understanding the Warning System

If a warning light comes on during operation, stop the machine immediately and correct the problem before continuing operation. Serious damage could occur if you operate the machine with a malfunction.

## Mowing

Start the engine and move the engine-speed switch to the FAST position. Move the Enable/Disable switch to the ENABLE position and use the Lower Mow/Raise lever to control the cutting units (the front cutting units are timed to lower before the rear cutting units). To move forward and cut grass, press the traction pedal forward.

## Transporting the Machine

Move the Enable/Disable switch to the DISABLE position and raise the cutting units to the TRANSPORT position. Move the Mow/Transport lever to the TRANSPORT position. Be careful when driving between objects so you do not accidentally damage the machine or cutting units. Use extra care when operating the machine on slopes. Drive slowly and avoid sharp turns on slopes to prevent rollovers. Lower the cutting units when going downhill for steering control.

## After Operation

### After Operation Safety

#### General Safety

- Park the machine on a level surface.
- Disengage and lower the cutting units.
- Engage the parking brake.
- Shut off the engine and remove the key.
- Wait for all movement to stop.
- Allow the machine to cool before adjusting, servicing, cleaning, or storing it.
- Clean grass and debris from the cutting units, drives, mufflers, cooling screens, and engine compartment to help prevent fires. Clean up oil or fuel spills.
- Disengage the drive to the attachment whenever you are hauling or not using the machine.
- Maintain and clean the seat belt(s) as necessary.
- Do not store the machine or fuel container where there is an open flame, spark, or pilot light, such as on a water heater or on other appliances.

# Tie-Down Point Locations

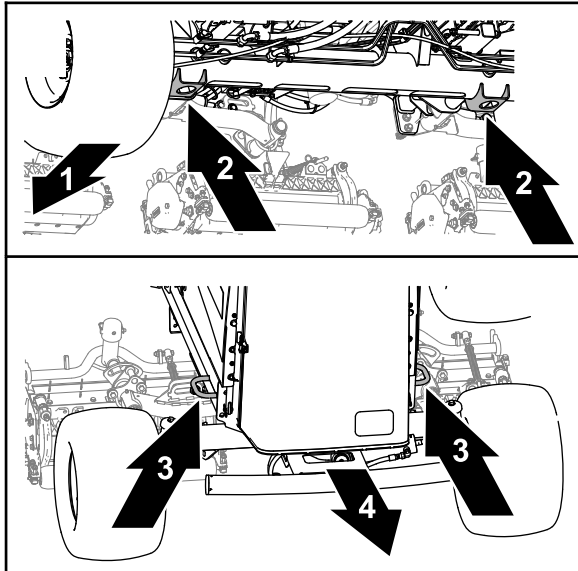

Figure 57

- |                                    |                        |
|------------------------------------|------------------------|
| 1. Front of the machine            | 3. Frame hoops         |
| 2. Jack brackets (front axle tube) | 4. Back of the machine |

- Front—the hole in the jack brackets of the front-axle tube (Figure 57).
- Rear—the frame hoops at each side of the machine.

## Hauling the Machine

- Use full-width ramps for loading the machine onto a trailer or truck.
- Tie the machine down securely.

## Pushing or Towing the Machine

In an emergency, you can move the machine by actuating the bypass valve in the variable displacement hydraulic pump and pushing or towing the machine.

**Important:** Do not push or tow the machine faster than 3 to 4.8 km/h (2 to 3 mph) because internal transmission damage may occur. The bypass valve must be open whenever you push or tow the machine.

1. Engage the parking brake, shut off the engine, and remove the key.
2. Open the hood; refer to [Opening the Hood \(page 43\)](#).

3. At the variable-displacement pump, rotate the bypass-valve bolt 1-1/2 turns to open and allow oil to bypass internally (Figure 58).

**Note:** The bypass valve is located at the left side of the pump. By bypassing the fluid, you can move the machine slowly without damaging the transmission.

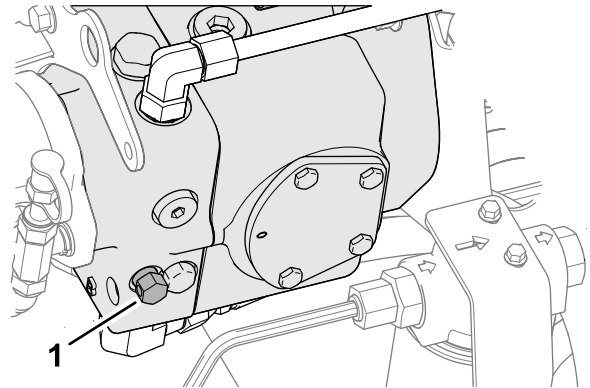

Figure 58

1. Bypass-valve bolt

4. Close and latch the hood.
5. Push or tow the machine.
6. Before starting the engine, close the bypass valve. Do not exceed 7 to 11 N·m (5 to 8 ft·lb) torque to close the valve.

**Important:** Running the engine with the bypass valve open causes the transmission to overheat.

# Maintenance

**Note:** Determine the left and right sides of the machine from the normal operating position.

**Note:** Download a free copy of the electrical or hydraulic schematic by visiting [www.Toro.com](http://www.Toro.com) and searching for your machine from the Manuals link on the home page.

## Maintenance Safety

- Before you leave the operator’s position, do the following:
  - Park the machine on a level surface.
  - Disengage and lower the cutting units.
  - Engage the parking brake.
  - Shut off the engine and remove the key.
  - Wait for all movement to stop.
  - Allow the machine to cool before adjusting, servicing, cleaning, or storing it.
- Allow machine components to cool before performing maintenance.
- If possible, do not perform maintenance while the engine is running. Keep away from moving parts.
- Support the machine with jack stands whenever you work under the machine.
- Carefully release pressure from components with stored energy.
- Keep all parts of the machine in good working condition and all hardware tightened.
- Replace all worn or damaged decals.
- To ensure safe, optimal performance of the machine, use only genuine Toro replacement parts. Replacement parts made by other manufacturers could be dangerous, and such use could void the product warranty.

## Recommended Maintenance Schedule(s)

Maintenance Service Interval	Maintenance Procedure
After the first hour	<ul style="list-style-type: none"> <li>• Torque the wheel lug nuts to 94 to 122 N·m (70 to 90 ft-lb).</li> </ul>
After the first 8 hours	<ul style="list-style-type: none"> <li>• Check the condition and tension of the alternator belt.</li> </ul>
After the first 10 hours	<ul style="list-style-type: none"> <li>• Torque the wheel lug nuts to 94 to 122 N·m (70 to 90 ft-lb).</li> </ul>
After the first 50 hours	<ul style="list-style-type: none"> <li>• Change the engine oil and filter.</li> <li>• Check the engine speed (idle and full throttle).</li> </ul>
Before each use or daily	<ul style="list-style-type: none"> <li>• Inspect the seat belt(s) for wear, cuts, and other damage. Replace the seat belt(s) if any component does not operate properly.</li> <li>• Check the interlock switches.</li> <li>•</li> <li>• Check the level of the engine oil.</li> <li>• Drain water and contaminants from the fuel-water separator.</li> <li>• Check the tire air pressure.</li> <li>• Check the coolant level.</li> <li>• Remove debris from the screen, oil coolers, and radiator. (More frequently in dirty operating conditions).</li> <li>• Check the hydraulic-fluid level.</li> <li>• Check the hydraulic lines and hoses.</li> <li>• Check the reel to bedknife contact.</li> <li>• Inspect the seat belt.</li> </ul>
Every 50 hours	<ul style="list-style-type: none"> <li>• Grease the bearings and bushings (and immediately after every washing).</li> <li>• Service the battery.</li> </ul>
Every 100 hours	<ul style="list-style-type: none"> <li>• Inspect the cooling system hoses.</li> <li>• Check the condition and tension of the alternator belt.</li> </ul>
Every 150 hours	<ul style="list-style-type: none"> <li>• Change the engine oil and filter.</li> </ul>
Every 200 hours	<ul style="list-style-type: none"> <li>• Drain moisture from the fuel and hydraulic fluid tanks.</li> </ul>

<b>Maintenance Service Interval</b>	<b>Maintenance Procedure</b>
Every 250 hours	<ul style="list-style-type: none"> <li>• Torque the wheel lug nuts to 94 to 122 N·m (70 to 90 ft-lb).</li> </ul>
Every 400 hours	<ul style="list-style-type: none"> <li>• Service the air cleaner. (more frequently in extremely dirty or dusty conditions). Service the air cleaner earlier if the air-cleaner indicator shows red.</li> <li>• Replace the fuel filter.</li> <li>• Check the fuel lines and connections for deterioration, damage, or loose connections. (Or yearly, whichever comes first).</li> <li>• Check the engine speed (idle and full throttle).</li> </ul>
Every 800 hours	<ul style="list-style-type: none"> <li>• Drain and clean the fuel tank. Drain and clean the fuel tank if the fuel system becomes contaminated.</li> <li>• Check the rear wheel toe-in.</li> <li>• If you are not using the recommended hydraulic fluid or have ever filled the reservoir with an alternative fluid, replace the charge filter.</li> <li>• If you are not using the recommended hydraulic fluid or have ever filled the reservoir with an alternative fluid, change the hydraulic fluid.</li> <li>• Pack the rear wheel bearings.</li> <li>• Adjust the engine valves (refer to the engine service manual).</li> </ul>
Every 1,000 hours	<ul style="list-style-type: none"> <li>• If you are using the recommended hydraulic fluid, replace the charge filter.</li> </ul>
Every 2,000 hours	<ul style="list-style-type: none"> <li>• If you are using the recommended hydraulic fluid, change the hydraulic fluid.</li> </ul>
Before storage	<ul style="list-style-type: none"> <li>• Drain and clean the fuel tank. Drain and clean the fuel tank if you store the machine for an extended period.</li> </ul>
Every 2 years	<ul style="list-style-type: none"> <li>• Flush and replace the cooling system fluid.</li> <li>• Replace the hydraulic hoses.</li> <li>• Replace the coolant hoses.</li> <li>• Flush and replace the coolant.</li> <li>• Replace all moving hoses.</li> </ul>

# Daily Maintenance Checklist

Duplicate this page for routine use.

Maintenance Check Item	For the week of:						
	Mon.	Tues.	Wed.	Thurs.	Fri.	Sat.	Sun.
Check the safety interlock operation.							
Check the brake operation.							
Check the levels of the engine oil and fuel.							
Check the cooling-system fluid level.							
Drain the water/fuel separator.							
Check the air-filter service indicator.							
Check the radiator, oil cooler, and screen for debris.							
Check for unusual engine noises. <sup>1</sup>							
Check for unusual operating noises.							
Check the fluid level of the hydraulic system.							
Check the hydraulic hoses for damage.							
Check for fluid leaks.							
Check the tire pressure.							
Check the instrument operation.							
Check the reel-to-bedknife adjustment.							
Check the height-of-cut adjustment.							
Lubricate all grease fittings. <sup>2</sup>							
Touch-up damaged paint.							

1. Check the glow plug and injector nozzles if the engine starts hard, produces excess smoke, or runs rough.

2. Immediately after every washing, regardless of the interval listed

**Important:** Refer to your engine operator's manual for additional maintenance procedures.

## Notation for Areas of Concern

Inspection performed by:		
Item	Date	Information
1		
2		
3		
4		
5		
6		
7		
8		

# Pre-Maintenance Procedures

## Preparing for Maintenance

1. Park the machine on a level surface.
2. Engage the parking brake.
3. Press the enable/disable switch to the DISENGAGE position.
4. Move the lower mow/raise control to the Mow position.
5. Shut off the engine, and remove the key.
6. Wait for all parts to stop moving.
7. Allow the engine to cool.

## Opening the Hood

1. Release the 2 hood latches (Figure 59).

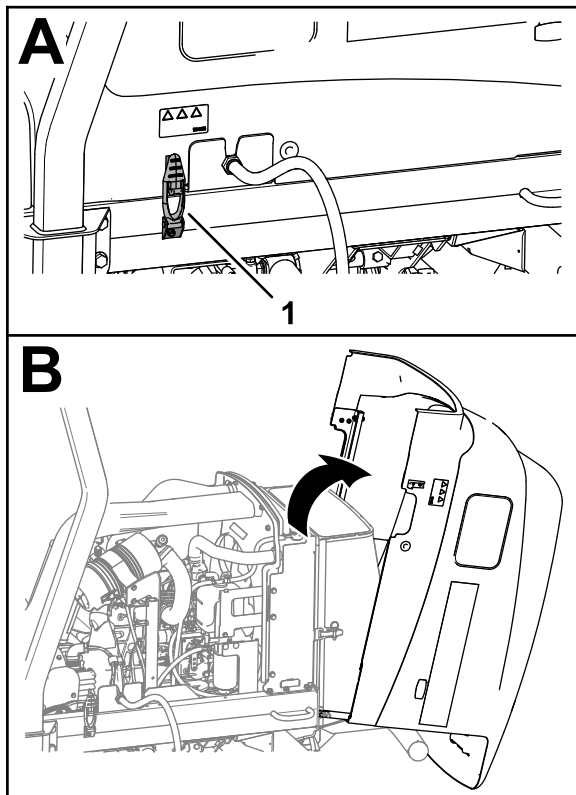

Figure 59

g377320

1. Hood latch (2)
2. Rotate open the hood.

## Closing the Hood

1. Carefully rotate the hood closed (Figure 60).

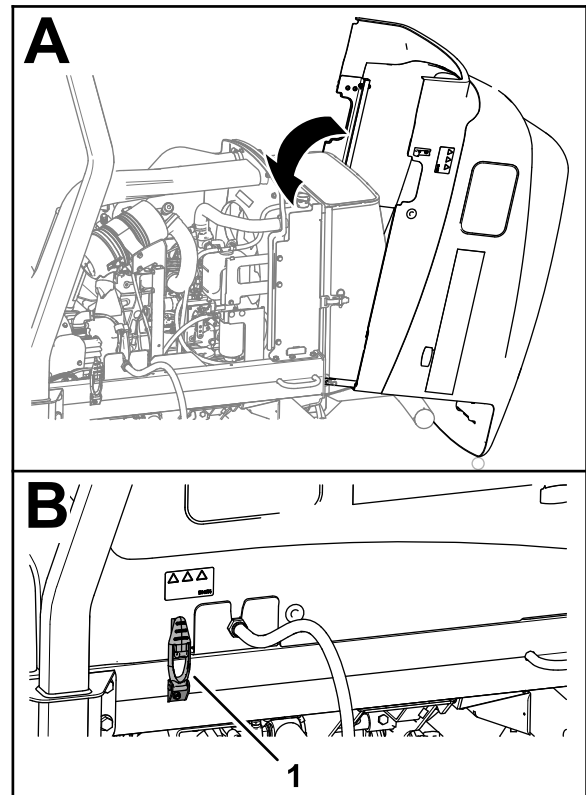

Figure 60

g377319

1. Hood latch (2)
2. Secure the hood with the 2 hood latches.

## Opening the Screen

1. Remove the ball pin from the screen latch (Figure 61).

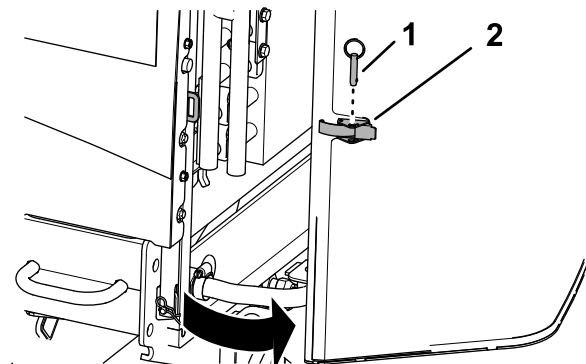

Figure 61

g378822

1. Ball pin
2. Screen latch
2. Unlatch and open the screen.

# Closing the Screen

1. Close and latch the screen (Figure 62).

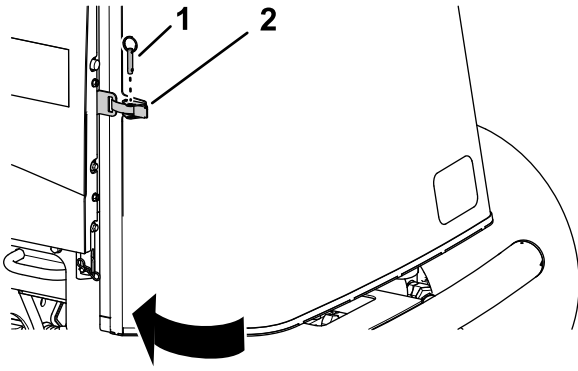

Figure 62

g378174

1. Ball pin
2. Screen latch

2. Insert the ball pin through the screen latch.

# Tilting the Seat

1. Move the seat latch outward (Figure 63).

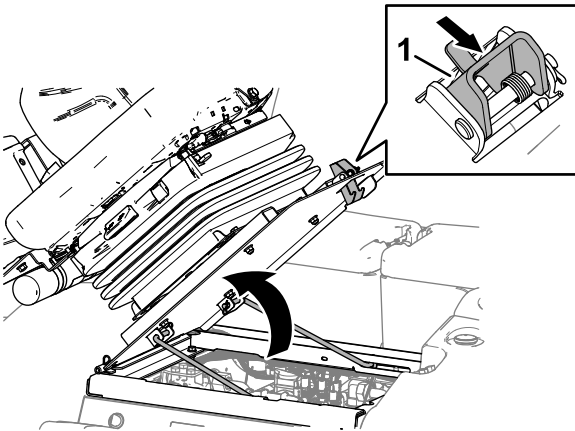

Figure 63

g369007

1. Seat latch

2. Carefully rotate the seat up.
3. Ensure that the forward prop rod seats in the slot detent of the rod-guide plate (Figure 64).

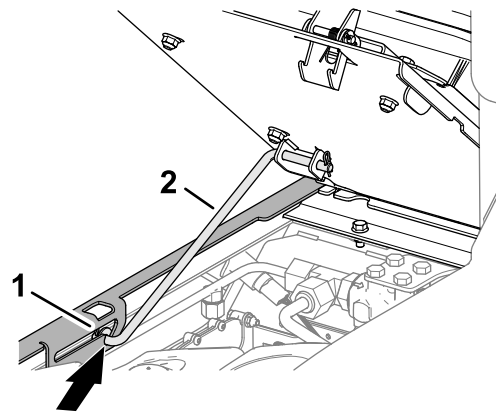

Figure 64

g369008

1. Prop rod
2. Rod-guide plate

# Lowering the Seat

1. Rotate the seat slightly, and lift the prop rod out of the dent of the seat support slot (Figure 65).

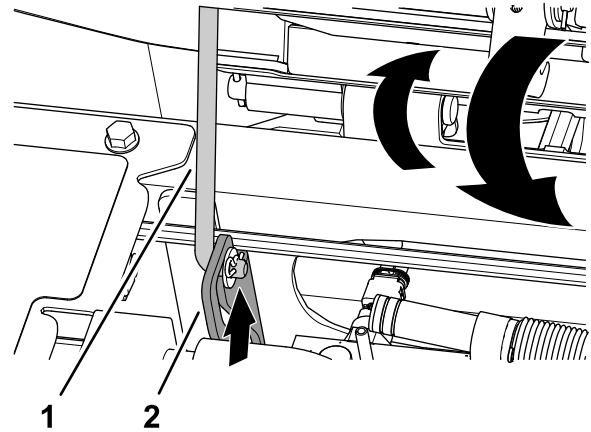

Figure 65

g375779

1. Prop rod
2. Rod-guide plate

2. Carefully lower the seat until it latches securely.



# Separating the Generator Cooling-Air Shrouds

1. Remove the 4 flange-head capscrews and 4 flange locknuts that secure the upper and lower generator cooling-air shrouds (Figure 66).

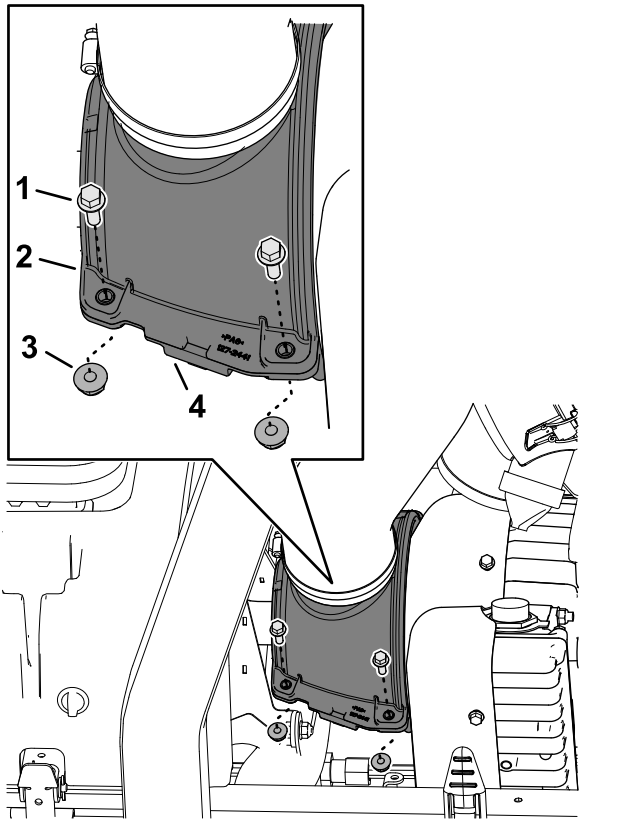

Figure 66

- |                                       |                                       |
|---------------------------------------|---------------------------------------|
| 1. Flange-head capscrew               | 3. Flange locknut                     |
| 2. Upper generator cooling-air shroud | 4. Lower generator cooling-air shroud |

2. Separate the shrouds.
3. Lift the upper shroud to access the grease fittings of the driveshaft.

# Assembling the Generator Cooling-Air Shrouds

1. Align the grooves in the top and bottom generator cooling-air shrouds with the driveshaft-brush seal and the flange of the generator cover (Figure 67).

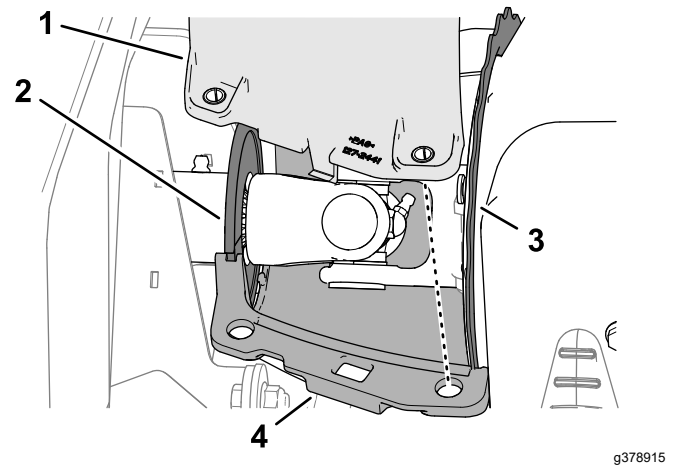
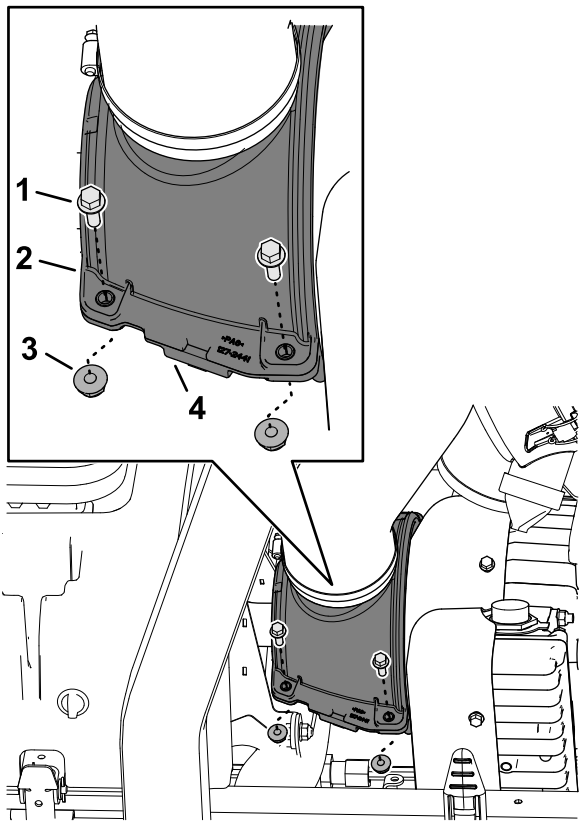

Figure 67

- |                                       |                                       |
|---------------------------------------|---------------------------------------|
| 1. Upper generator cooling-air shroud | 3. Flange (generator cover)           |
| 2. Driveshaft-brush seal              | 4. Lower generator cooling-air shroud |

2. Align the holes in the generator cooling-air shrouds with the compression-limiting pins.
3. Secure the halves of the generator cooling-air shrouds and compression-limiting pins with the 4 flange-head capscrews and 4 flange locknuts (Figure 68).



**Figure 68**

g378913

- |                                       |                                       |
|---------------------------------------|---------------------------------------|
| 1. Flange-head capscrew               | 3. Flange locknut                     |
| 2. Upper generator cooling-air shroud | 4. Lower generator cooling-air shroud |

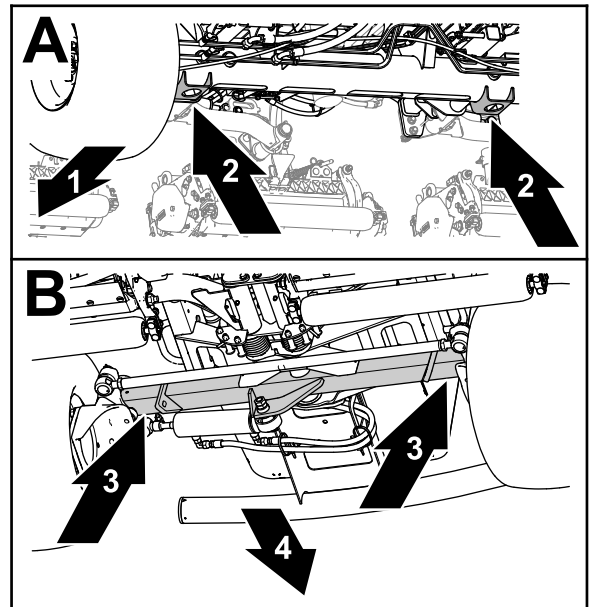

g375763

**Figure 69**

- |                                    |                             |
|------------------------------------|-----------------------------|
| 1. Front of the machine            | 3. Rear-axle tube           |
| 2. Jack brackets (front-axle tube) | 4. Back of the machine tube |

- Front—the jack brackets of the front-axle tube ([Figure 69](#)).
- Rear—the rear-axle tube.

## Jacking Point Locations

**Note:** Support the machine with jack stands whenever you work under the machine; refer to [Specifications \(page 30\)](#).

Use the following as machine-lift points:

# Lubrication

## Greasing the Bearings and Bushings

**Service Interval:** Every 50 hours (and immediately after every washing).

**Grease Specification:** No. 2 lithium grease

1. Prepare the machine for maintenance; refer to [Preparing for Maintenance \(page 43\)](#). Open the hood; refer to [Opening the Hood \(page 43\)](#)
2. Separate the generator cooling-air shrouds; refer to [Separating the Generator Cooling-Air Shrouds \(page 45\)](#).
3. Lubricate all grease fittings for the bearings and bushings with the specified grease. The grease fitting locations and quantities are as follows:

- Pump driveshaft U-joint (3) ([Figure 70](#))

**Note:** Access the pump driveshaft from the bottom of the machine.

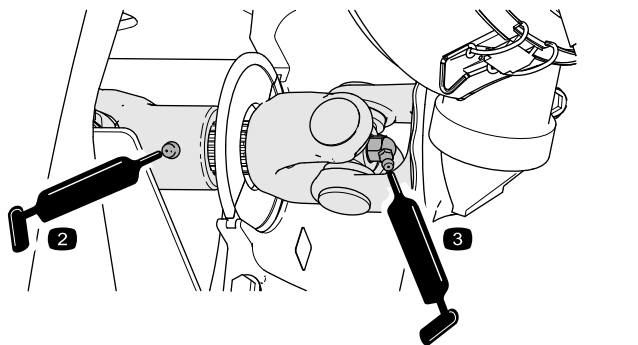
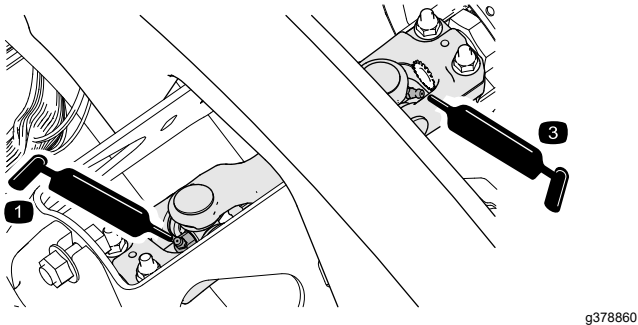

Figure 70

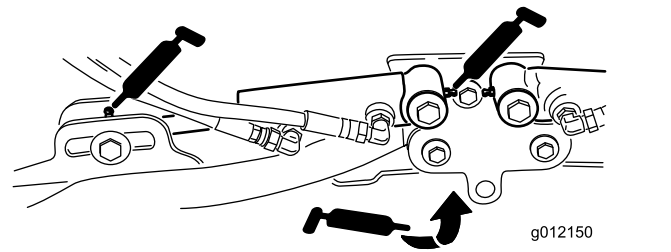

Figure 71

- Lift-arm pivots (1 each) ([Figure 71](#))
- Cutting-unit carrier-frame and pivot (2 each) ([Figure 72](#))

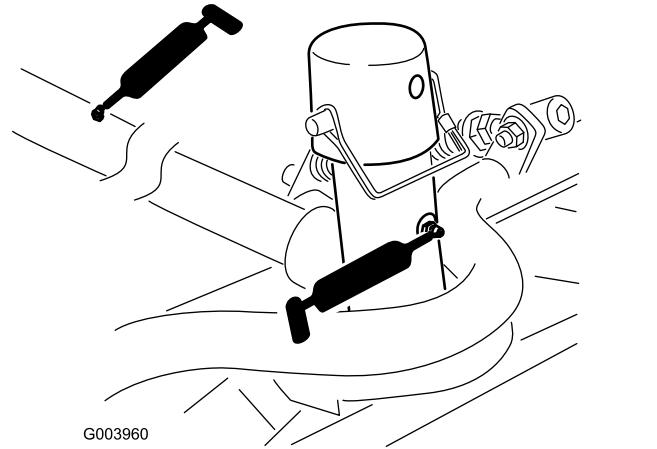

Figure 72

- Lift-arm-pivot shaft (1 each) ([Figure 73](#))

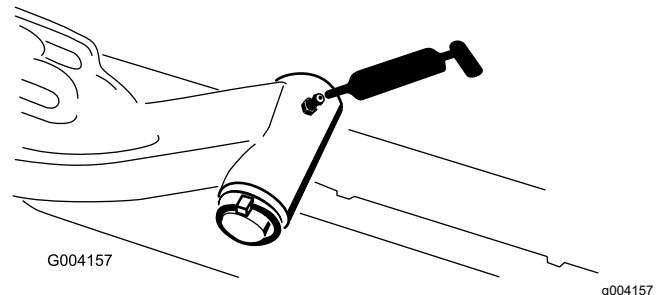

Figure 73

- Axle-steering pivot (1) ([Figure 74](#))

- Cutting-unit lift-arm cylinders (2 each) ([Figure 71](#))

# Engine Maintenance

## Engine Safety

- Shut off the engine before checking the oil or adding oil to the crankcase.
- Do not change the governor speed or overspeed the engine.

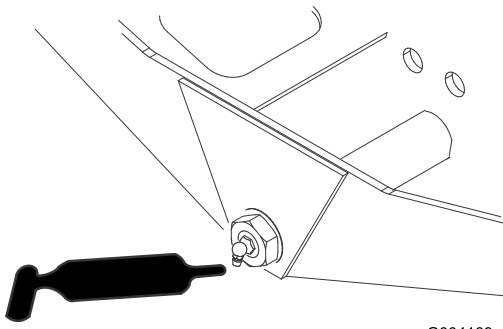

Figure 74

- Steering-cylinder ball joints (2) (Figure 75)

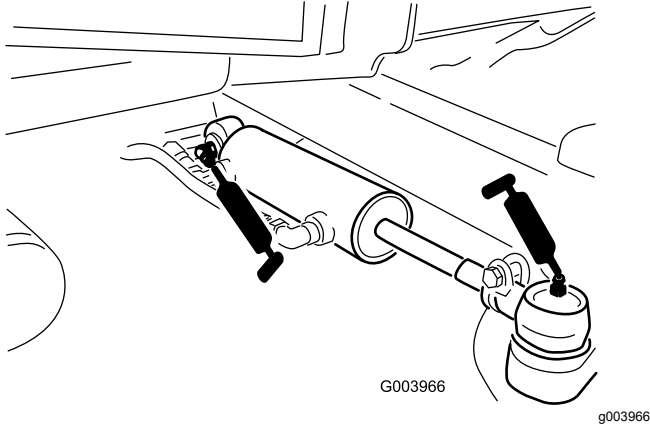

Figure 75

- Brake pedal (1) (Figure 76)

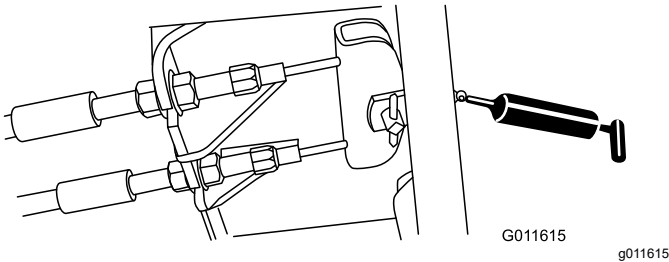

Figure 76

4. Assemble the generator cooling-air shrouds; refer to [Assembling the Generator Cooling-Air Shrouds \(page 45\)](#).
5. Lower and latch the seat; refer to [Lowering the Seat \(page 44\)](#).
6. Close and latch the hood; refer to [Closing the Hood \(page 43\)](#).

## Checking the Air Filter

**Service Interval:** Before each use or daily

1. Prepare the machine for maintenance; refer to [Preparing for Maintenance \(page 43\)](#).
2. Open the hood; refer to [Opening the Hood \(page 43\)](#).
3. Check the service indicator at the end of the air filter housing (Figure 77).

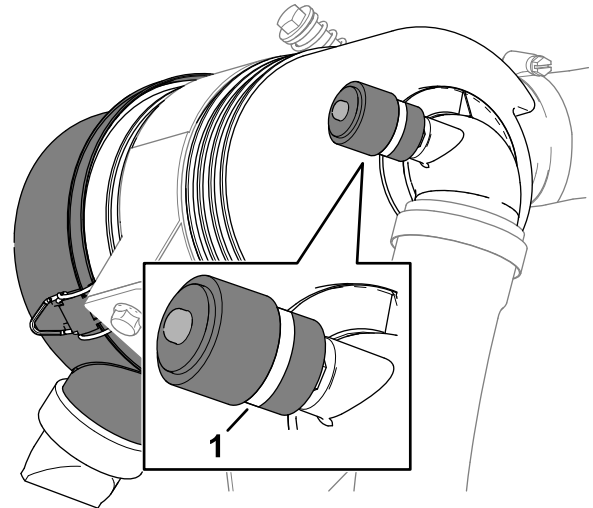

Figure 77

1. Service indicator

4. If a red band displays in the service indicator, change the air filter; refer to [Servicing the Air Cleaner \(page 49\)](#).
5. Squeeze the dust-ejector valve (Figure 78).

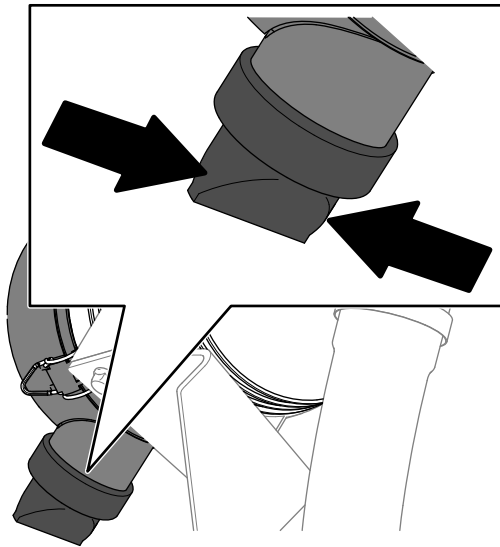

Figure 78

g373568

6. Close and latch the hood; refer to [Closing the Hood \(page 43\)](#).

## Servicing the Air Cleaner

**Service Interval:** Every 400 hours (more frequently in extremely dirty or dusty conditions). Service the air cleaner earlier if the air-cleaner indicator shows red.

Check the air-cleaner body for damage which could cause an air leak. Replace it if it is damaged. Check the whole intake system for leaks, damage, or loose hose clamps.

Service the air-cleaner filter only when the service indicator requires it. Changing the air filter before it is necessary only increases the chance of dirt entering the engine when you remove the filter.

**Important:** Make sure that the cover is seated correctly and seals with the air-cleaner body.

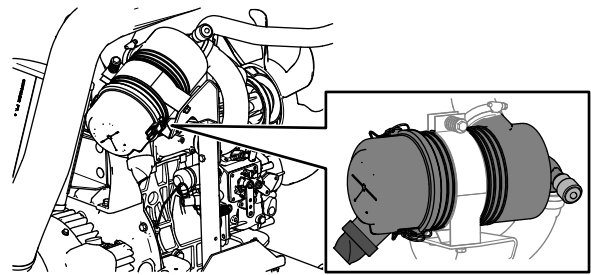

g378927

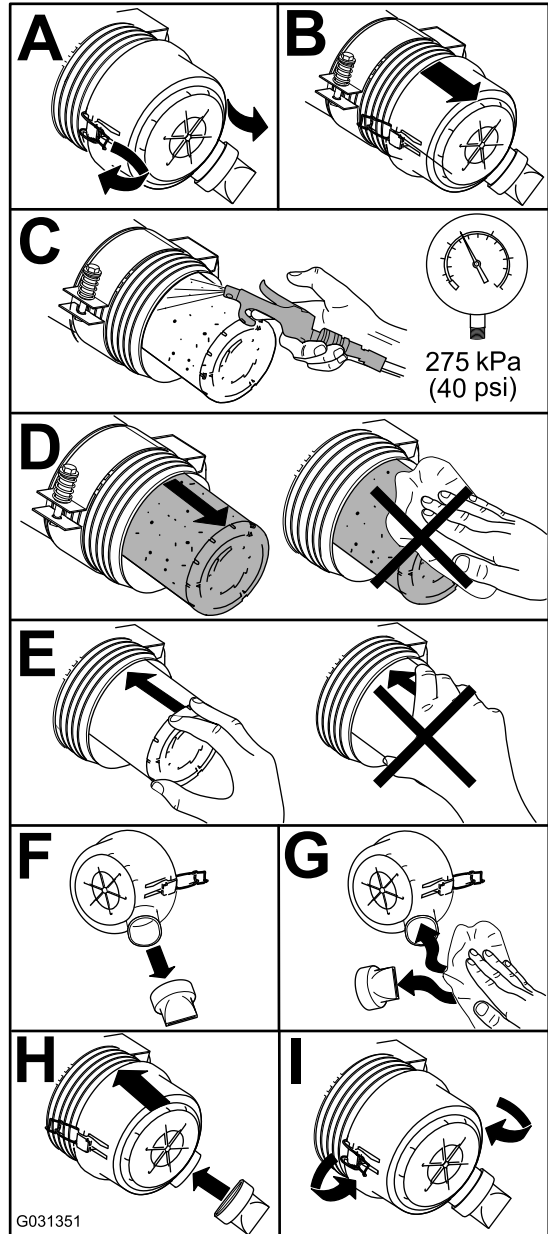

G031351

g031351

Figure 79

# Resetting the Air Filter Service Indicator

1. If a red band displays in the service indicator, press the reset button at the end of the indicator (Figure 80).

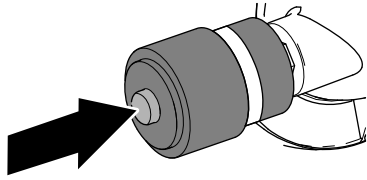

Figure 80

g373569

2. Close and latch the hood; refer to [Closing the Hood \(page 43\)](#).

## Oil Specification

Use high-quality, low-ash engine oil that meets or exceeds API service category CH-4 or higher.

Use the following engine oil viscosity grade:

- Preferred oil: SAE 15W-40 (above 0°F)
- Alternate oil: SAE 10W-30 or 5W-30 (all temperatures)

Toro Premium Engine Oil is available from your authorized Toro distributor in either 15W-40 or 10W-30 viscosity grades.

## Checking the Level of the Engine Oil

**Service Interval:** Before each use or daily

**Important:** Check the engine oil daily. If the engine-oil level is above the Full mark on the dipstick, the engine oil may be diluted with fuel; if the engine oil level is above the Full mark, change the engine oil.

The best time to check the engine oil is when the engine is cool before it has been started for the day. If it has already been run, allow the oil to drain back down to the sump for at least 10 minutes before checking. If the oil level is at or below the Add mark on the dipstick, add oil to bring the oil level to the Full mark. **Do not overfill the engine with oil.**

**Important:** Keep the engine oil level between the upper and lower limits on the oil gauge; the engine may fail if you run it with too much or too little oil.

1. Prepare the machine for maintenance; refer to [Preparing for Maintenance \(page 43\)](#).

2. Open the hood; refer to [Opening the Hood \(page 43\)](#).
3. Check the level of the engine oil (Figure 81).

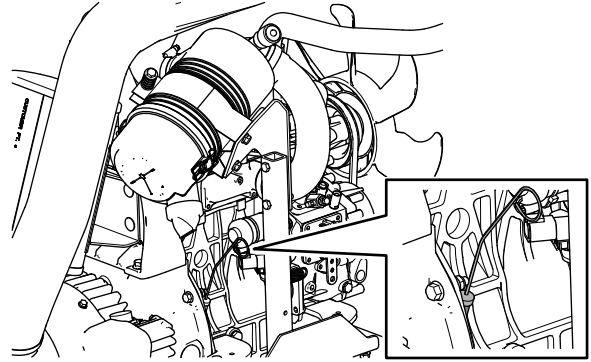

g378928

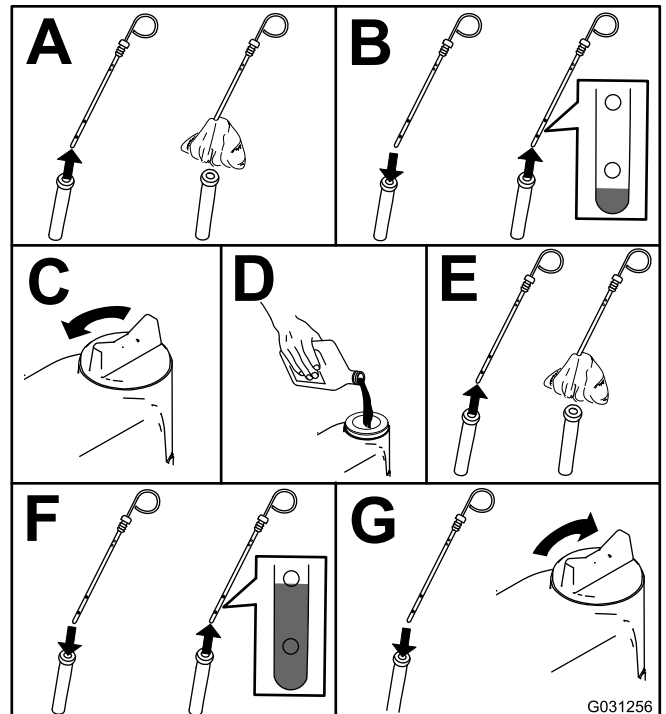

G031256

g031256

Figure 81

**Important:** Be sure to keep the level of the engine oil between the upper and lower limits on the oil gauge. Engine failure may occur because of over filling or under filling the engine oil.

4. Close and latch the hood; refer to [Closing the Hood \(page 43\)](#).

# Crankcase Oil Capacity

Approximately 3.3 L (3.5 US qt) with the filter.

## Changing the Engine Oil and Filter

**Service Interval:** After the first 50 hours—Change the engine oil and filter.

Every 150 hours

1. Prepare the machine; refer to [Preparing for Maintenance \(page 43\)](#).
2. Drain the oil and change the filter.

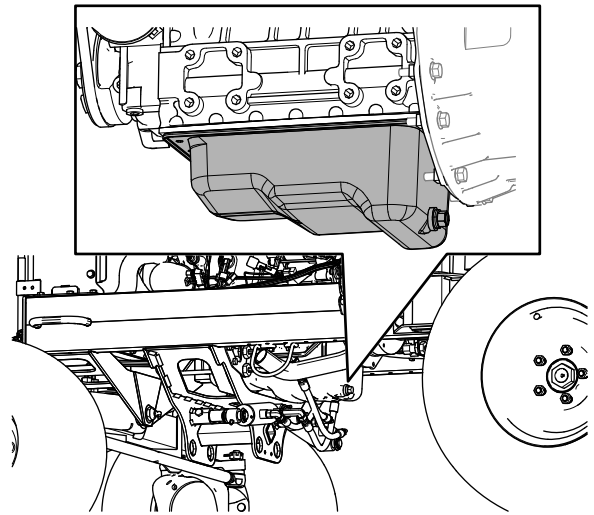

g373614

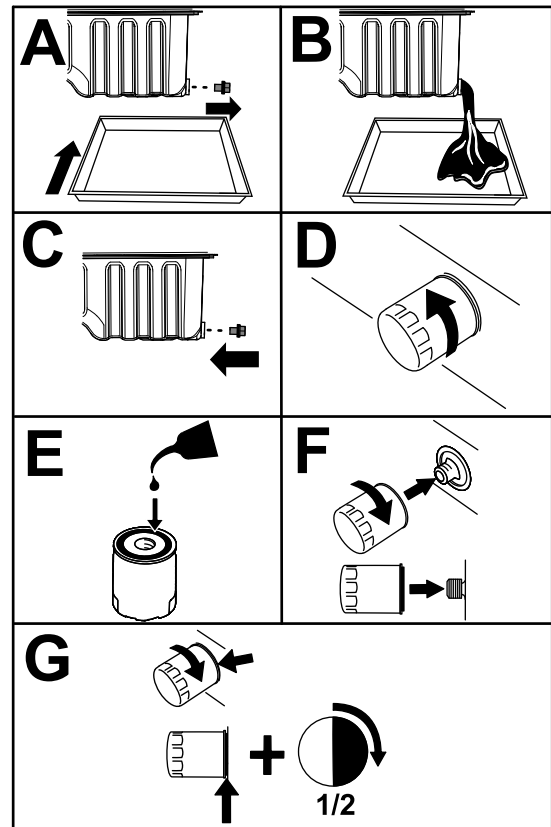

g378573

Figure 82

**Important:** Do not overtighten the filter.

3. Open the hood; refer to [Opening the Hood \(page 43\)](#).
4. Add oil to the crankcase; refer to [Oil Specification \(page 50\)](#), [Crankcase Oil Capacity \(page 51\)](#), and [Checking the Level of the Engine Oil \(page 50\)](#).
5. Close and latch the hood; refer to [Closing the Hood \(page 43\)](#).



# Fuel System Maintenance

## **⚠ DANGER**

Under certain conditions, fuel and fuel vapors are highly flammable and explosive. A fire or explosion from fuel can burn you and others and can cause property damage.

- Fill the fuel tank outdoors, in an open area, when the engine is off and is cold. Wipe up any fuel that spills.
- Do not fill the fuel tank completely full. Add fuel to the fuel tank until the level is 25 mm (1 inch) below the top of the tank, not the filler neck. This empty space in the tank allows the fuel to expand.
- Never smoke when handling fuel, and stay away from an open flame or where fuel fumes may be ignited by a spark.
- Store fuel in a clean, safety-approved container and keep the cap in place.

## Draining Water from the Fuel-Water Separator

**Service Interval:** Before each use or daily—Drain water and contaminants from the fuel-water separator.

1. Prepare the machine for maintenance; refer to [Preparing for Maintenance \(page 43\)](#).
2. Open the hood; [Opening the Hood \(page 43\)](#).
3. Align a drain pan under the drain valve of the fuel-water separator ([Figure 83](#)).

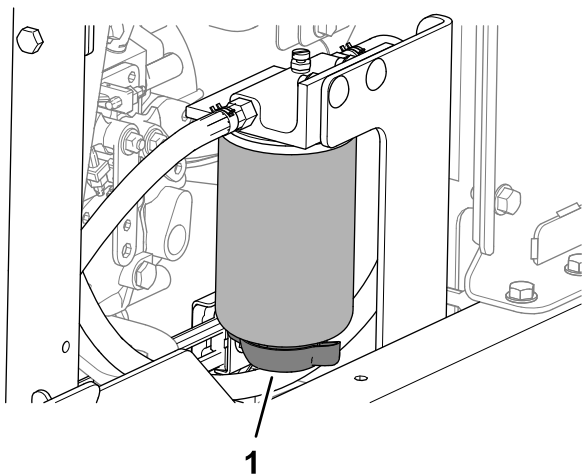

**Figure 83**

g375850

1. Drain valve (fuel-water separator)

4. Open the valve and drain the water and contaminants from the separator.
5. Close the valve of the fuel-water separator.
6. Start the engine and check for leaks.

**Note:** Repair all leaks.

7. Shut off the engine and remove the key.
8. Close and latch the hood; [Closing the Hood \(page 43\)](#).

## Replacing the Water-Separator Filter

**Service Interval:** Every 400 hours

1. Fully drain the fuel-water separator; refer to [Draining Water from the Fuel-Water Separator \(page 52\)](#).
2. Clean the filter head and filter canister ([Figure 84](#)).

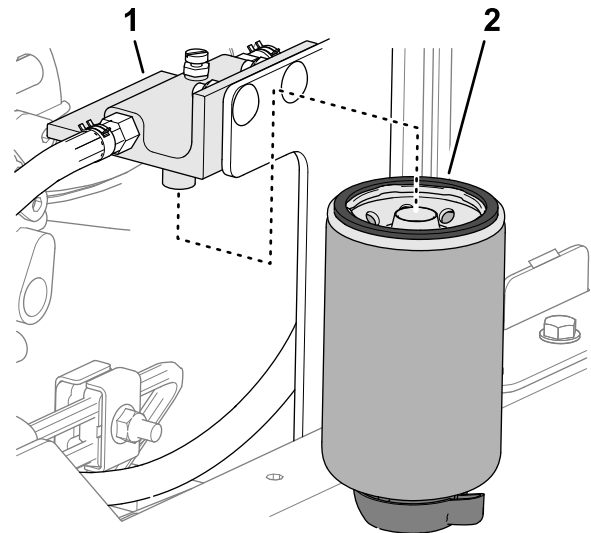

**Figure 84**

g375851

1. Filter head
2. Filter canister

3. Remove the filter canister, and clean the mounting surface of the filter head.
4. Lubricate the gasket on the filter canister with clean fuel.
5. Install the filter canister by hand until the gasket contacts the mounting surface, then rotate it an additional 1/2 turn.
6. Tighten the drain valve at the bottom of the filter canister.
7. Start the engine and check for leaks.

**Note:** Repair all leaks.

8. Shut off the engine and remove the key.



9. Close and latch the hood; refer to [Closing the Hood \(page 43\)](#).

## Bleeding the Fuel System

1. Prepare the machine for maintenance; refer to [Preparing for Maintenance \(page 43\)](#).
2. Ensure that the fuel tank is at least half full.
3. Open the hood; refer to [Opening the Hood \(page 43\)](#).
4. Open the air-bleed screw on the fuel-injection pump ([Figure 85](#)).

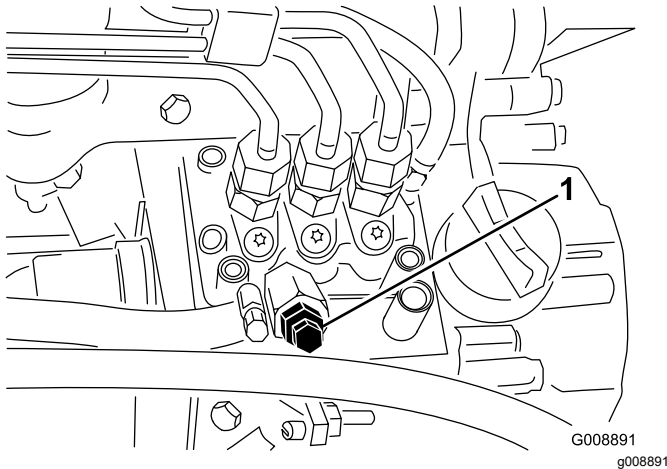

**Figure 85**

1. Fuel-injection pump bleed screw

5. Turn the key in the ignition switch to the ON position.  
The electric fuel pump runs, forcing air out around the air-bleed screw.  
**Note:** Leave the key in the ON position until a solid stream of fuel flows out around the screw.
6. Tighten the screw and turn the ignition key to OFF.
7. Close and latch the hood; refer to [Closing the Hood \(page 43\)](#).

## Checking the Fuel Lines and Connections

**Service Interval:** Every 400 hours (Or yearly, whichever comes first).

Check the fuel lines and connections for deterioration, damage, or loose connections.

## Draining the Fuel Tank

**Service Interval:** Every 800 hours Drain and clean the fuel tank if the fuel system becomes contaminated.

Before storage Drain and clean the fuel tank if you store the machine for an extended period.

**Fuel-tank capacity:** 53 L (14 US gallons)

1. Prepare the machine for maintenance; refer to [Preparing for Maintenance \(page 43\)](#).
2. Align a drain pan under the fuel tank-drain valve ([Figure 86](#)).

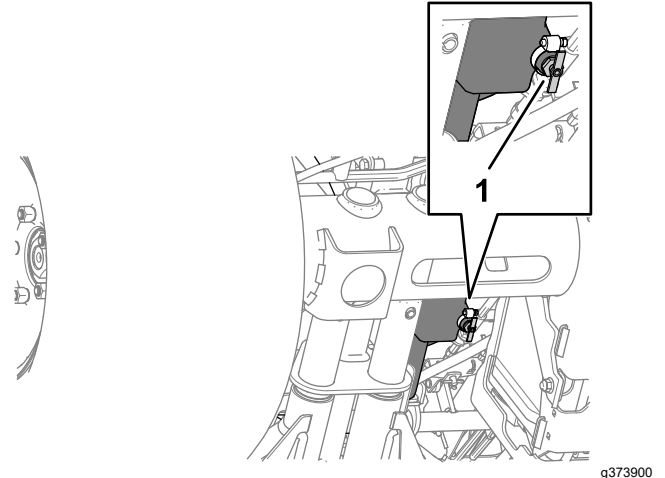

**Figure 86**

1. Drain valve (fuel tank)
3. Open the drain valve and allow the fuel to drain from the tank.
4. Use clean fuel to flush out the tank.
5. Close the drain valve.

## Cleaning the Fuel-Pickup Tube Screen

### Removing the Fuel-Pickup Tube

The fuel-pickup tube, located inside the fuel tank, comes with a screen to help prevent debris from entering the fuel system. Remove the fuel-pickup tube and clean the screen as required.

1. Prepare the machine for maintenance; refer to [Preparing for Maintenance \(page 43\)](#).
2. Remove the 5 Phillips-head screws that secure the fuel-sender cover to the fuel tank, and remove the cover ([Figure 87](#)).

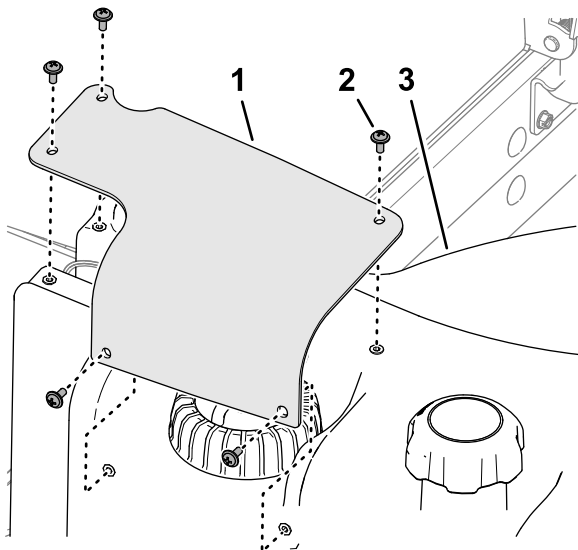
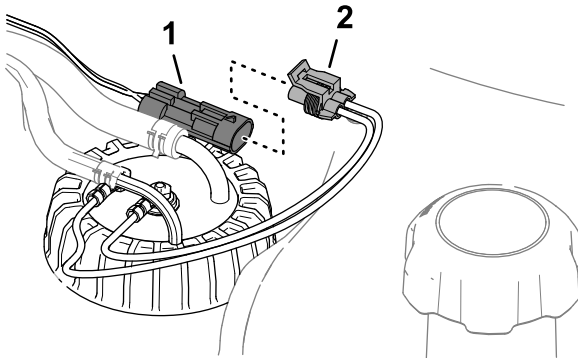

**Figure 87**

g373885

1. Fuel-sender cover
2. Phillips-head screw
3. Fuel tank

3. Remove the 2-socket connector of the fuel-sender harness from the 2-pin connector of the machine wire harness ([Figure 88](#)).

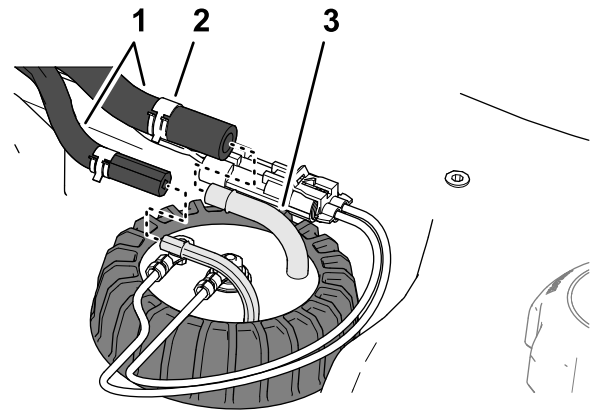

**Figure 88**

g373884

1. 2-pin connector (machine wire harness)
2. 2-socket connector (fuel sender)

4. Move the clamps that secure the hoses to the fittings of the fuel sender inboard, and remove the hoses from the fittings ([Figure 89](#)).

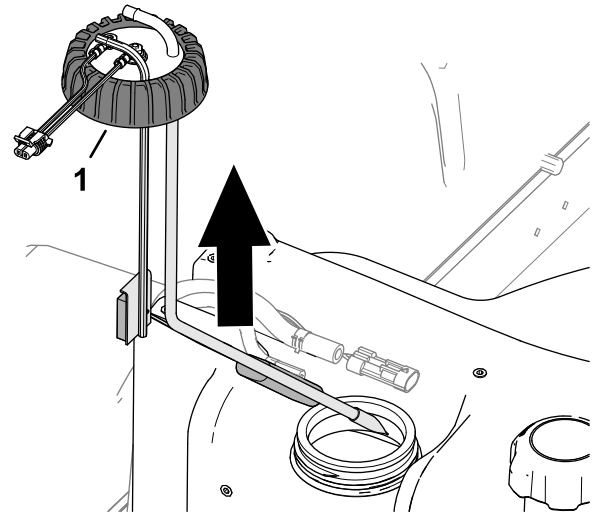

**Figure 89**

g373882

1. Hoses
2. Clamp
3. Fitting (fuel sender)

5. Loosen the fuel-sender cap ([Figure 90](#)).



**Figure 90**

g373883

1. Cap (fuel sender)

6. Carefully lift the fuel sender from the tank.

**Note:** Do not bend the pick-up tube, return tube, or float arm.

# Cleaning the Installing the Fuel-Pickup Tube

1. Clean the screen at the end of the fuel pick-up tube (Figure 91).

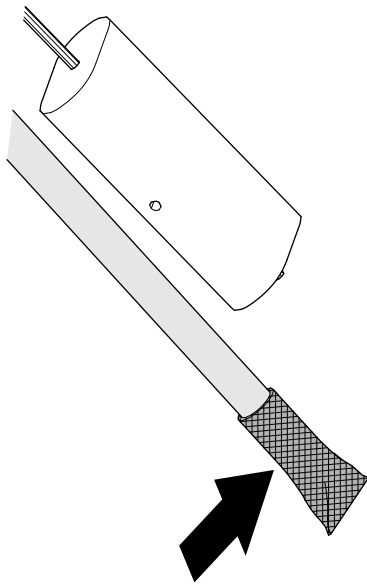

Figure 91

g373881

2. Carefully assemble the fuel pick-up tube and float into the fuel tank (Figure 92).

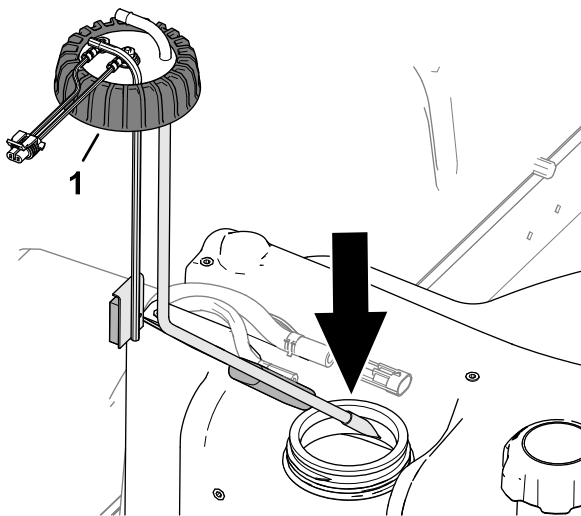

Figure 92

g373886

1. Cap (fuel sender)

3. Align the fittings for the pick-up tube and return tube inboard.
4. Tighten the fuel-sender cap to the fuel tank.
5. Assemble the hose onto the fittings of the fuel sender, and secure the hoses to the fittings with the clamps (Figure 93).

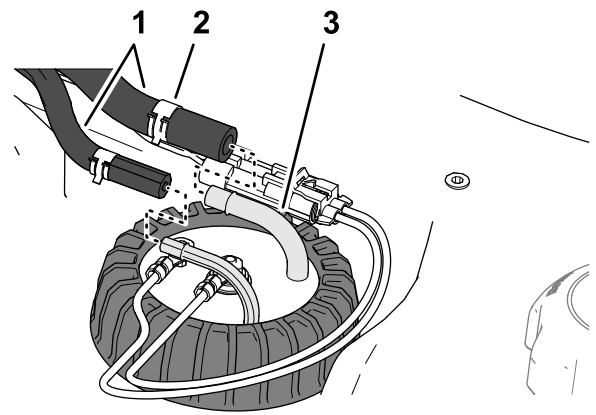

Figure 93

g373882

1. Hoses
2. Clamp
3. Fitting (fuel sender)

6. Plug the connector of the fuel-sender harness into the connector of the machine wire harness (Figure 94).

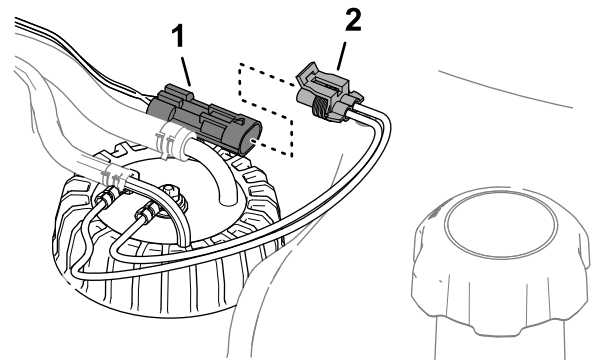
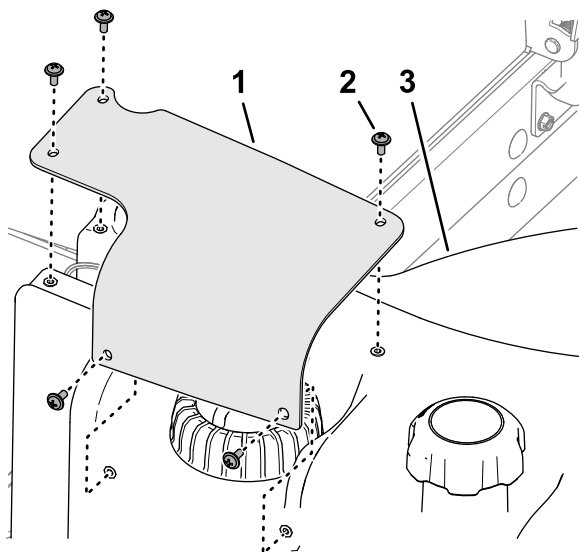

Figure 94

g373884

1. 2-pin connector (machine wire harness)
2. 2-socket connector (fuel sender)

7. Align the holes in the fuel-sender cover with the holes in the fuel tank, and secure the cover to the tank with the 5 Phillips-head screws (Figure 95).



**Figure 95**

g373885

- |                        |              |
|------------------------|--------------|
| 1. Fuel-sender cover   | 3. Fuel tank |
| 2. Phillips-head screw |              |

## Electrical System Maintenance

**Important:** Before welding on the machine, disconnect all cables from the battery, both wire harness plugs from the electronic control module, and the terminal connector from the alternator to prevent damage to the electrical system.

## Electrical System Safety

- Disconnect the battery before repairing the machine. Disconnect the negative terminal first and the positive last. Connect the positive terminal first and the negative last.
- Charge the battery in an open, well-ventilated area, away from sparks and flames. Unplug the charger before connecting or disconnecting the battery. Wear protective clothing and use insulated tools.

## Disconnecting the 12 V Battery

### **⚠ DANGER**

Battery electrolyte contains sulfuric acid, which is fatal if consumed and causes severe burns.

- Do not drink electrolyte and avoid contact with skin, eyes, or clothing. Wear safety glasses to shield your eyes and rubber gloves to protect your hands.
  - Fill the battery where clean water is always available for flushing the skin.
1. Prepare the machine for maintenance; refer to [Preparing for Maintenance \(page 43\)](#).
  2. Open the screen; refer to [Opening the Screen \(page 43\)](#).
  3. Press the sides of the battery cover, and remove the cover from the battery tray ([Figure 96](#)).

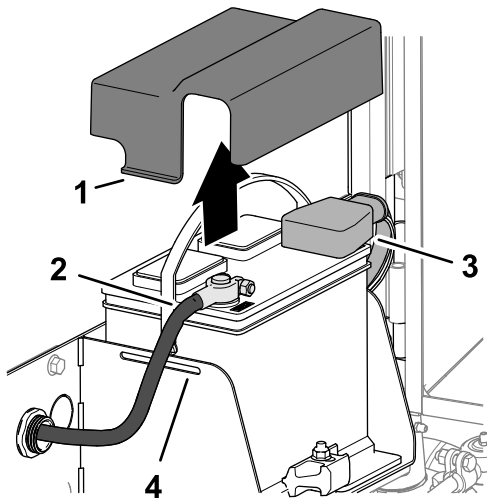

Figure 96

g378176

- |                           |   |
|---------------------------|---|
| 1. Tab (battery cover)    | 3. Insulator cover (positive battery cable) |
| 2. Negative battery cable | 4. Slot (battery tray)                      |

4. Disconnect the negative battery cable.
5. Slide the insulator cover off the positive battery-cable clamp, and disconnect the positive battery cable.

## Connecting the 12 V Battery

1. Install the positive battery cable (red) to the positive (+) battery post (Figure 97).

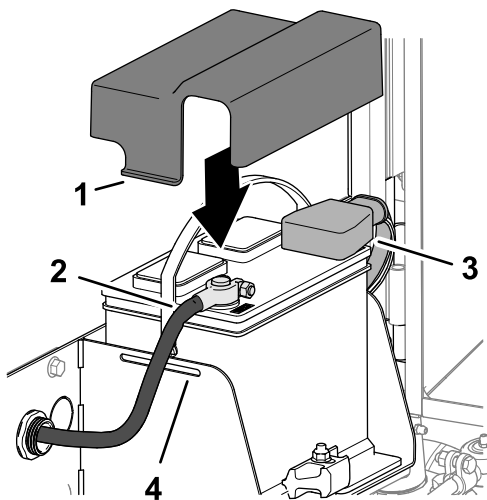

Figure 97

g378177

- |                           |   |
|---------------------------|---|
| 1. Tab (battery cover)    | 3. Insulator cover (positive battery cable) |
| 2. Negative battery cable | 4. Slot (battery tray)                      |

2. Install the negative battery cable (black) to the negative (-) battery post.

3. Apply a coat of Grafo 112X (skin-over) grease, Toro Part No. 505-47 to the battery posts and battery-cable clamps.
4. Slide the rubber boot over the positive battery-cable clamp.
5. Assemble the cover over the battery, inserting the tabs of the cover into the slots in the battery tray.
6. Close and latch the screen; refer to [Closing the Screen \(page 44\)](#).

## Charging the 12 V Battery

1. Disconnect the battery; refer to [Disconnecting the 12 V Battery \(page 56\)](#).
2. Connect a 3 to 4 A battery charger to the battery posts.
3. Charge the battery at a rate of 3 to 4 A for 4 to 8 hours.
4. When the battery is charged, disconnect the charger from the electrical outlet and battery posts.
5. Connect the battery; refer to [Connecting the 12 V Battery \(page 57\)](#).

## Servicing the 12 V Battery

**Service Interval:** Every 50 hours

**Note:** Keep the terminals and the entire battery case clean because a dirty battery will discharge slowly.

1. Prepare the machine for maintenance; refer to [Preparing for Maintenance \(page 43\)](#).
2. Open the screen; refer to [Opening the Screen \(page 43\)](#).
3. Check the condition of the battery.

**Note:** Replace a worn or damaged battery.

4. Disconnect the battery cables, and remove the battery from the machine; refer to [Disconnecting the 12 V Battery \(page 56\)](#).
5. Clean the entire battery case with a solution of sodium bicarbonate (baking soda) and water.
6. Rinse the case with clean water.
7. Assemble the battery to the machine and connect the battery cables; refer to [Connecting the 12 V Battery \(page 57\)](#).
8. Close and latch the screen; refer to [Closing the Screen \(page 44\)](#).

# Replacing a 12 V Fuse-Block Fuse

The fuse block is in the control arm.

1. Prepare the machine for maintenance; refer to [Preparing for Maintenance \(page 43\)](#).
2. Open the 2 latches that secure control-arm cover to the control arm, and remove the cover ([Figure 98](#)).

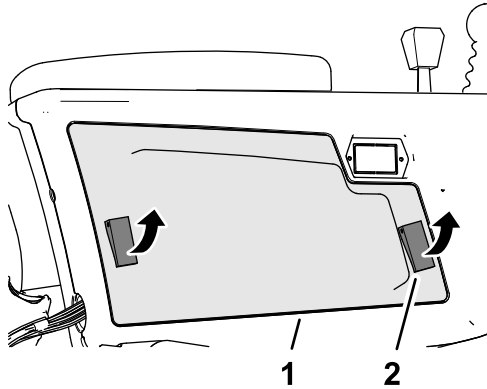

Figure 98

g375760

1. Control-arm cover
2. Latch

3. Replace the open fuse ([Figure 99](#)) with the same fuse type and amperage rating.

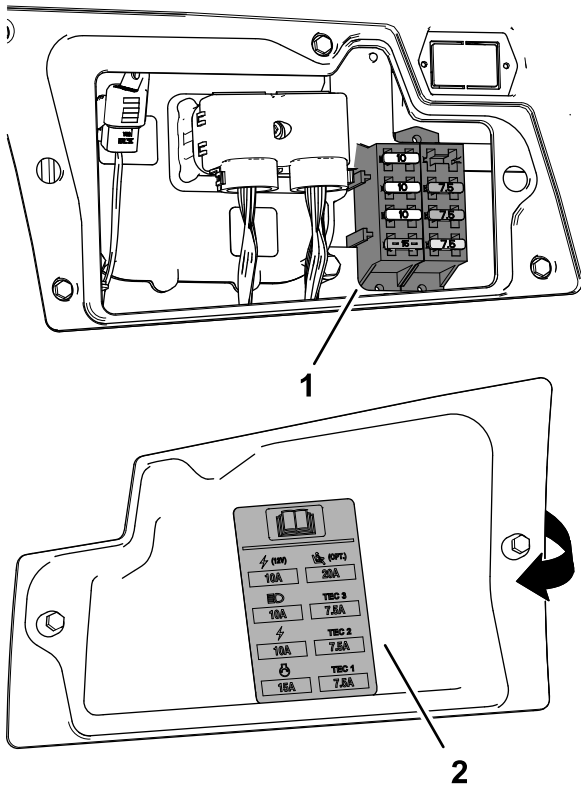

Figure 99

g375761

1. Fuse block
2. Fuse decal (inside the control-arm cover)

4. Assemble the control-arm cover to the control arm, and secure the cover with the 2 latches.

# Replacing a 48 V Cutting Unit Fuse

1. Prepare the machine for maintenance; refer to [Preparing for Maintenance \(page 43\)](#).
2. Unlatch and open the hood; refer to [Opening the Hood \(page 43\)](#).
3. At the front, left side of the engine, remove the cover for the 48 V fuse-block.

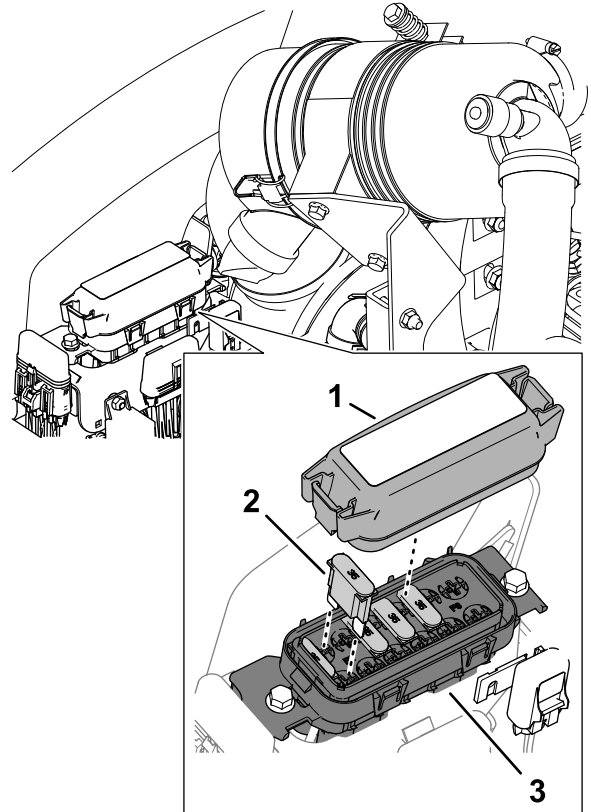

Figure 100

g379036

1. Cover
2. Maxi fuse
3. 48 V fuse block

4. Replace the open fuse with a fuse of the same type and amperage rating.

**Note:** Refer to the decal on the cover.



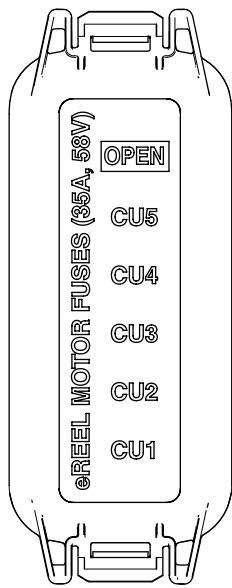

Figure 101

g379037

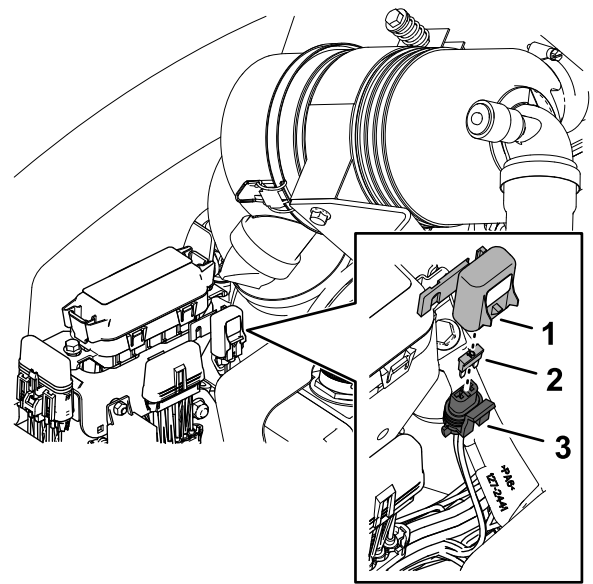

Figure 102

g379038

5. Assemble the cover to the 48 V fuse-block.
6. Close and latch the hood; refer to [Closing the Hood \(page 43\)](#).

## Replacing the Reel Enable Fuse

1. Prepare the machine for maintenance; refer to [Preparing for Maintenance \(page 43\)](#).
2. Unlatch and open the hood; refer to [Opening the Hood \(page 43\)](#).
3. At the front, left side of the engine, Remove the cap from the in-line fuse holder labeled ENABLE FUSE 10 A 125 V.

1. Cap
  2. Fuse
  3. Fuse holder (labeled ENABLE FUSE 10 A 125 V)
4. Replace the open fuse with a fuse of the same type and amperage rating.
  5. Assemble the cap to the in-line fuse holder.
  6. Close and latch the hood; refer to [Closing the Hood \(page 43\)](#).

## Replacing the TEC Fuse

1. Prepare the machine for maintenance; refer to [Preparing for Maintenance \(page 43\)](#).
2. Unlatch and open the hood; refer to [Opening the Hood \(page 43\)](#).
3. At the rear, right side of the engine, remove the cover of the in-line fuse holder labeled 2A FUSE TEC PWR.

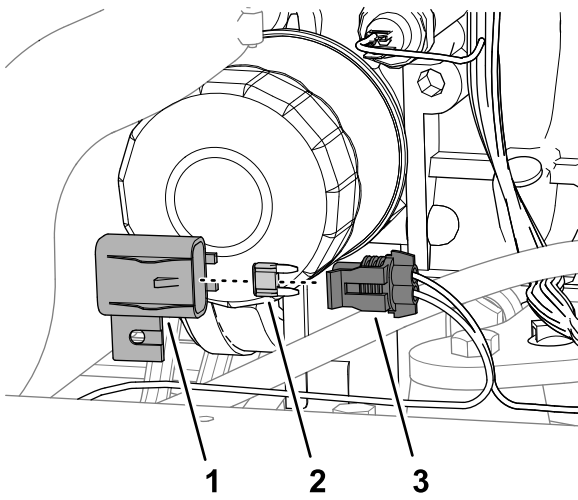

**Figure 103**

g379039

1. Cap
2. Fuse
3. Fuse holder (labeled 2A FUSE TEC PWR)

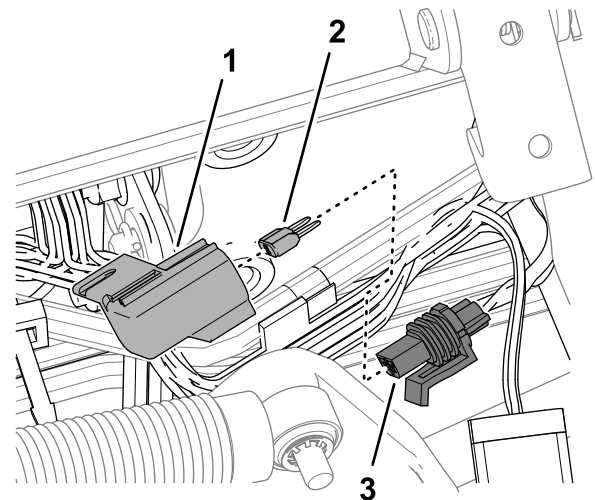

**Figure 104**

g378242

1. Cap
2. Fuse
3. Fuse holder (labeled 10 A FUSE TELEMATIC PWR)

4. Replace the open fuse with a fuse of the same type and amperage rating.
5. Assemble the cap to the in-line fuse holder.
6. Close and latch the hood; refer to [Closing the Hood \(page 43\)](#).

4. Remove the fuse from the fuse holder.
5. Insert a fuse of the same type and amperage.
6. Assemble the cap onto the in-line fuse holder.
7. Lower and latch the seat; refer to [Lowering the Seat \(page 44\)](#).

## Replacing the Telematic Fuse

1. Prepare the machine for maintenance; refer to [Preparing for Maintenance \(page 43\)](#).
2. Unlatch and tilt seat; refer to [Tilting the Seat \(page 44\)](#).
3. Remove the cap from the in-line fuse holder labeled 10 A FUSE TELEMATIC PWR ([Figure 104](#)).



# Drive System Maintenance

## Checking the Tire Air Pressure

**Service Interval:** Before each use or daily

**Important:** Maintain the recommended pressure in all tires to ensure a good quality of cut and proper machine performance. Do not underinflate the tires.

1. Prepare the machine for maintenance; refer to [Preparing for Maintenance \(page 43\)](#).
2. Measure the tire air pressure.  
**Note:** The correct air pressure in the tires is 83 to 103 kPa (12 to 15 psi).
3. If needed add air to or remove air from the tire.
4. Repeat steps 2 and 3 at the other tires.

## Checking the Torque of the Wheel Nuts

**Service Interval:** After the first hour  
After the first 10 hours  
Every 250 hours

### **▲ WARNING**

Failure to maintain proper torque of the wheel nuts could result in personal injury.

Maintain the proper torque on the wheel nuts.

1. Prepare the machine for maintenance; refer to [Preparing for Maintenance \(page 43\)](#).
2. Torque the wheel nuts to 94 to 122 N·m (70 to 90 ft-lb).

## Adjusting the Traction Drive for Neutral

**Important:** The machine must not move when the traction pedal is released (in the NEUTRAL position). If the machine moves, adjust traction pump as follows:

1. Prepare the machine for maintenance; refer to [Preparing for Maintenance \(page 43\)](#).
2. Jack up the front of the machine until the both front tires are off the ground, and support the

machine with jack stands, refer to [Specifications \(page 30\)](#) and [Jacking Point Locations \(page 46\)](#).

3. From the bottom of the machine and at the right side of the traction pump, loosen the locknut that secures the neutral return-adjustment screw ([Figure 105](#)).

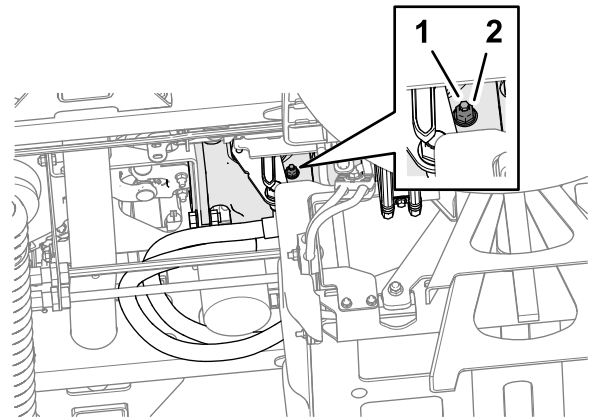

**Figure 105**

g379040

1. Neutral return-adjustment screw
2. Locknut
3. Traction pump

### **▲ WARNING**

The engine must be running so the final adjustment of the traction adjustment cam can be performed. This could cause personal injury.

Keep hands, feet, face, and other body parts away from the muffler, other hot parts of the engine, and any rotating parts.

4. Start the engine and release the parking brake.
5. Rotate the neutral return-adjustment screw in either direction until the wheels stop rotating.
6. Torque the locknut to 22 N·m (16 ft-lb).
7. Shut off the engine and remove the key.
8. Remove the jack stands, and lower the machine to the ground.
9. Test drive the machine to ensure that it does not move when the traction pedal is in the NEUTRAL position.

# Checking the Rear-Wheel Alignment

**Service Interval:** Every 800 hours—Check the rear wheel toe-in.

1. Rotate the steering wheel to position the rear wheels straight ahead.
2. Prepare the machine for maintenance; refer to [Preparing for Maintenance \(page 43\)](#).
3. At axle height, measure the center-to-center distance at the front and rear of the steering tires.

**Note:** The rear wheel toe-in adjustment is correct if the difference between the front wheel measurement and the rear wheel measurement is 6 mm (1/4 inch) or less. (Figure 106).

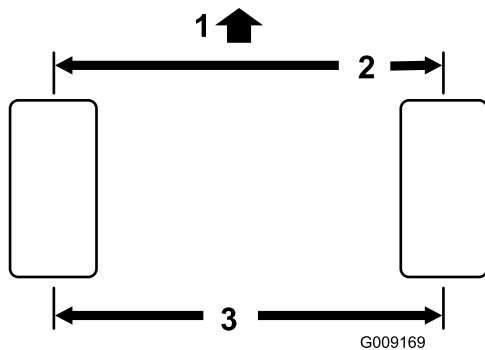

**Figure 106**

1. Front of the traction unit
2. 6 mm (1/4 inch) or less than the rear of the tire
3. Center-to-center distance

4. If the measurement is greater than 6 mm (1/4 inch), adjust the rear wheel toe-in; refer to [Adjusting the Rear Wheel Toe-in \(page 62\)](#).

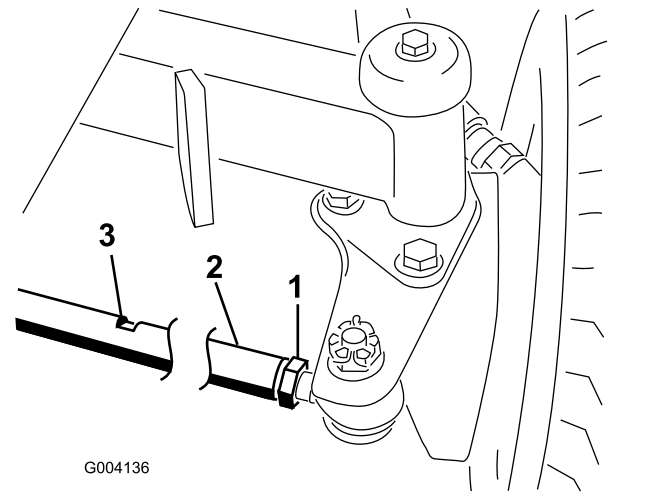

**Figure 107**

1. Jam nut
2. Tie rod
3. Wrench flat

2. Using the wrench flat to rotate the tie rod.
3. At axle height, measure the center-to-center distance at the front and rear of the steering tires.

**Note:** The rear wheel toe-in adjustment is correct if the difference between the front wheel measurement and the rear wheel measurement is 6 mm (1/4 inch) or less.

4. Repeat steps 2 and 3 as required.
5. Tighten the jam nuts.

# Adjusting the Rear Wheel Toe-in

1. Loosen the jam nut on each end of the tie rod ([Figure 107](#)).

**Note:** The end of the tie rod with the external groove is a left-hand thread.

# Cooling System Maintenance

## Cooling System Safety

- Swallowing engine coolant can cause poisoning; keep out of reach from children and pets.
- Discharge of hot, pressurized coolant or touching a hot radiator and surrounding parts can cause severe burns.
  - Always allow the engine to cool at least 15 minutes before removing the radiator cap.
  - Use a rag when opening the radiator cap, and open the cap slowly to allow steam to escape.

## Coolant Specification

The coolant reservoir is filled at the factory with a 50/50 solution of water and ethylene glycol base extended-life coolant.

**Important:** Use only commercially available coolants that meet the specifications listed in the Extended Life Coolant Standards Table.

Do not use conventional (green) inorganic-acid technology (IAT) coolant in your machine. Do not mix conventional coolant with extended-life coolant.

### Coolant Type Table

Ethylene-Glycol Coolant Type	Corrosion Inhibitor Type
Extended-life antifreeze	Organic-acid technology (OAT)

**Important:** Do not rely on the color of the coolant to identify the difference between conventional (green) inorganic-acid technology (IAT) coolant and extended-life coolant.

Coolant manufacturers may dye extended-life coolant in one of the following colors: red, pink, orange, yellow, blue, teal, violet, and green. Use coolant that meets the specifications in the Extended Life Coolant Standards Table.

### Extended Life Coolant Standards

ATSM International	SAE International
D3306 and D4985	J1034, J814, and 1941

**Important:** Coolant concentration should be a 50/50 mixture of coolant to water.

- **Preferred:** When mixing coolant from a concentrate, mix it with distilled water.

- **Preferred option:** If distilled water is not available, use a pre-mix coolant instead of a concentrate.
- **Minimum requirement:** If distilled water and pre-mix coolant are not available, mix concentrated coolant with clean drinkable water.

## Checking the Coolant Level

### ⚠ CAUTION

If the engine has been running, the pressurized, hot coolant can escape and cause burns.

- Do not open the radiator cap when the engine is running.
- Use a rag when opening the radiator cap, and open the cap slowly to allow steam to escape.

1. Prepare the machine for maintenance; refer to [Preparing for Maintenance \(page 43\)](#).
2. Open the hood; refer to [Opening the Hood \(page 43\)](#).
3. Check the level of coolant in the expansion tank ([Figure 108](#)).

**Note:** The coolant level is correct if it is between the add and full marks on the side of the tank.

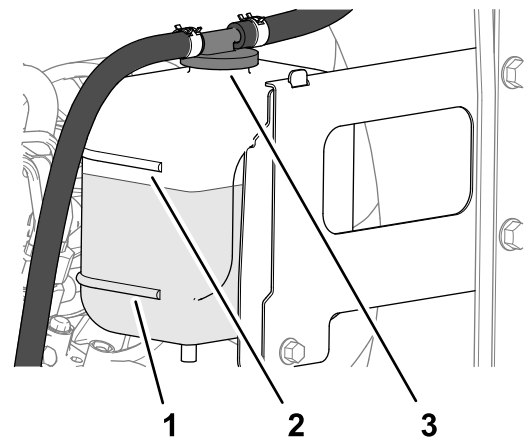

Figure 108

g375925

1. Expansion tank cap
2. Full mark
3. Add mark

4. If the coolant level is low, remove the expansion-tank cap and add the specified coolant until the level it is at the full mark.

**Note:** Do not overfill the expansion tank with coolant.

5. Install the expansion-tank cap.

6. Close and latch the hood; refer to [Closing the Hood \(page 43\)](#).

## Removing Debris from the Cooling System

**Service Interval:** Before each use or daily (More frequently in dirty operating conditions).

Every 100 hours—Inspect the cooling system hoses.

Every 2 years—Flush and replace the cooling system fluid.

1. Prepare the machine for maintenance; refer to [Preparing for Maintenance \(page 43\)](#).
2. Open the hood; refer to [Opening the Hood \(page 43\)](#).
3. Thoroughly clean all debris out of the engine area.
4. Close and latch the hood; refer to [Closing the Hood \(page 43\)](#).
5. Unlatch the rear screen and pivot it open ([Figure 109](#)).

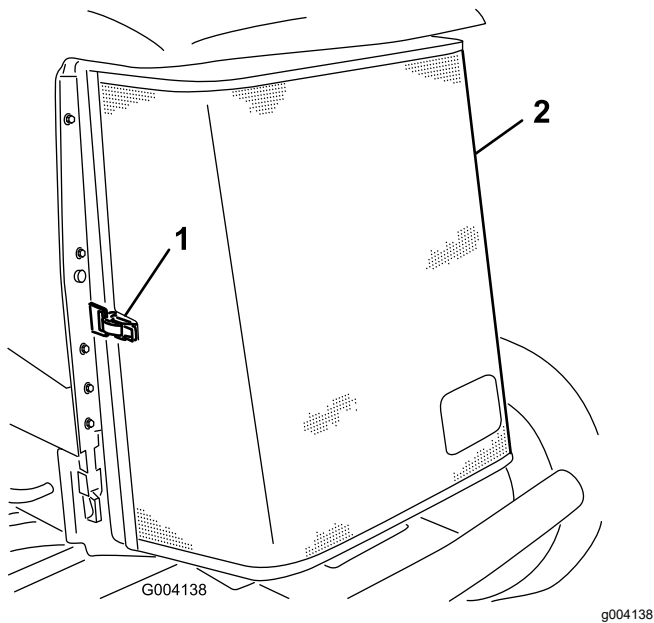

**Figure 109**

1. Latch
2. Rear screen

6. Thoroughly clean the screen with compressed air.
7. Rotate the 2 oil-cooler latches inward, and tilt the oil cooler ([Figure 110](#)).

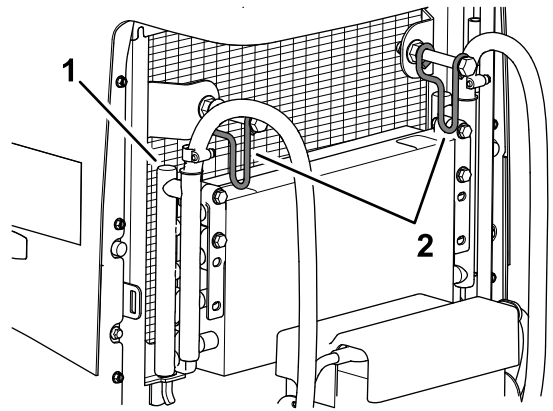

**Figure 110**

1. Oil cooler
2. Oil-cooler latches

8. Thoroughly clean both sides of the oil cooler and the radiator ([Figure 111](#)) with compressed air.

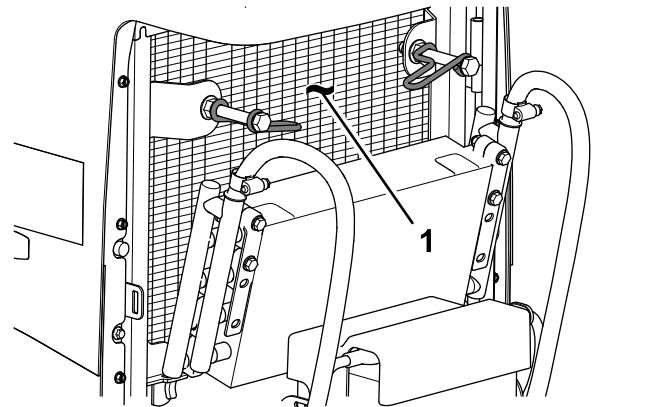

**Figure 111**

1. Radiator

9. Raise the oil cooler and secure it with the 2 latches.
10. Close and latch the screen.

# Brake Maintenance

## Adjusting the Parking Brakes

Adjust the service brakes when there is more than 13 mm (1/2 inch) of free travel of the brake pedal, or if the brakes slip. Free travel is the distance the brake pedal moves before you feel braking-pedal resistance.

1. Prepare the machine, refer to [Preparing for Maintenance \(page 43\)](#).
2. Release the parking brake.
3. Use the wheel-motor backlash to rock the drums back and forth to ensure that they are free, prior to and after the adjustment.
4. Lightly press the brake pedal; and measure the distance the pedal moves without resistance ([Figure 112](#)).

**Note:** Adjust the brakes if there is more than 2.5 cm (1 inch) of free travel ([Figure 112](#)) of the brake pedal, or if more parking-brake force is required.

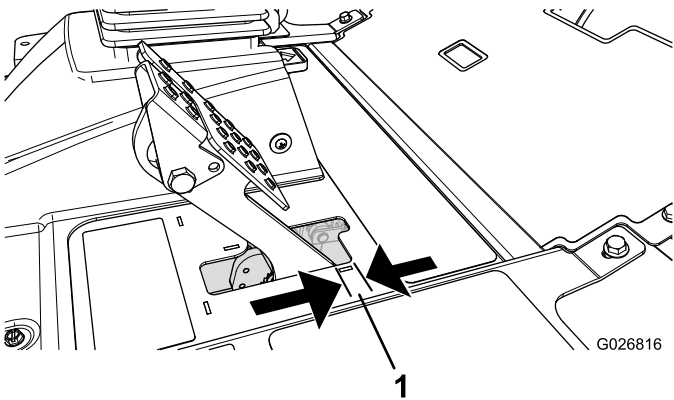

**Figure 112**

1. Free travel

5. To reduce brake pedal-free travel, loosen the front jam nuts on the threaded end of each brake cable ([Figure 113](#)).

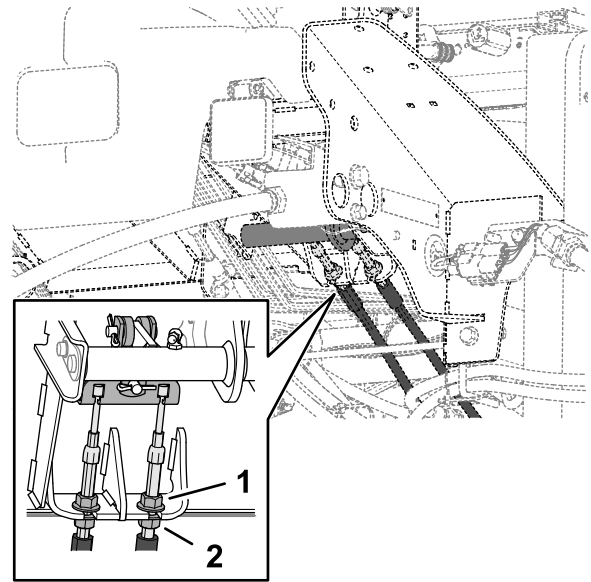

**Figure 113**

1. Front jam nut (brake cable) 2. Rear jam nut

6. Tighten the rear nuts to move the cable backward, until brake pedal has 6 to 13 mm (1/4 to 1/2 inch) of free travel ([Figure 112](#)), before the parking brake engages the wheels.
7. Tighten the front jam nuts, ensuring that both cables actuate the brakes simultaneously.

**Note:** Ensure that the cable conduit does not rotate while tightening the jam nuts.

## Adjusting the Parking-Brake Latch

If the parking brake fails to engage and latch, an adjustment to the brake pawl is required.

1. Prepare the machine, refer to [Preparing for Maintenance \(page 43\)](#).
2. Loosen the 2 screws securing the parking-brake pawl to the frame ([Figure 114](#)).

# Belt Maintenance

## Tensioning the Alternator Belt

**Service Interval:** After the first 8 hours—Check the condition and tension of the alternator belt.

Every 100 hours

1. Prepare the machine for maintenance; refer to [Preparing for Maintenance \(page 43\)](#).
2. Open the hood; refer to [Opening the Hood \(page 43\)](#).
3. Check the tension of the alternator belt by pressing it ([Figure 115](#)) midway between the alternator and the crankshaft pulleys with 10 kg (22 lb) of force.

**Note:** The belt should deflect 11 mm (7/16 inch). If the deflection is incorrect, proceed to step 4. If belt tension is correct, skip to step 7.

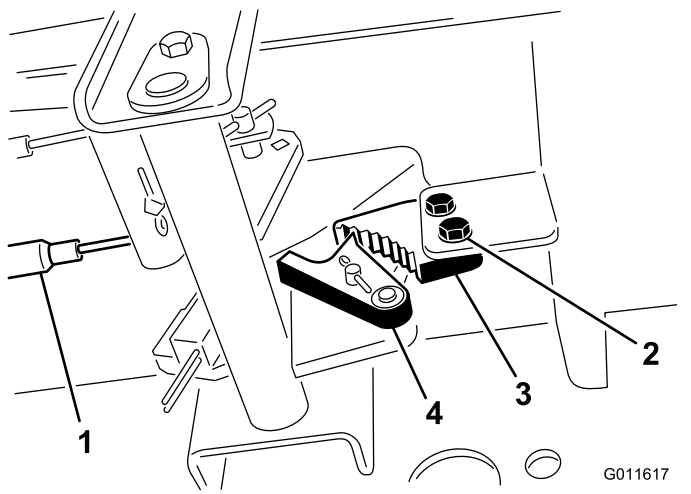

**Figure 114**

1. Brake cables
2. Screws (2)
3. Parking-brake pawl
4. Brake detent

3. Press the parking-brake pedal forward until the brake detent completely engages on the brake pawl ([Figure 114](#)).
4. Tighten the 2 screws locking the adjustment.
5. Press the brake pedal to release the parking brake.
6. Check the adjustment and adjust it as required.

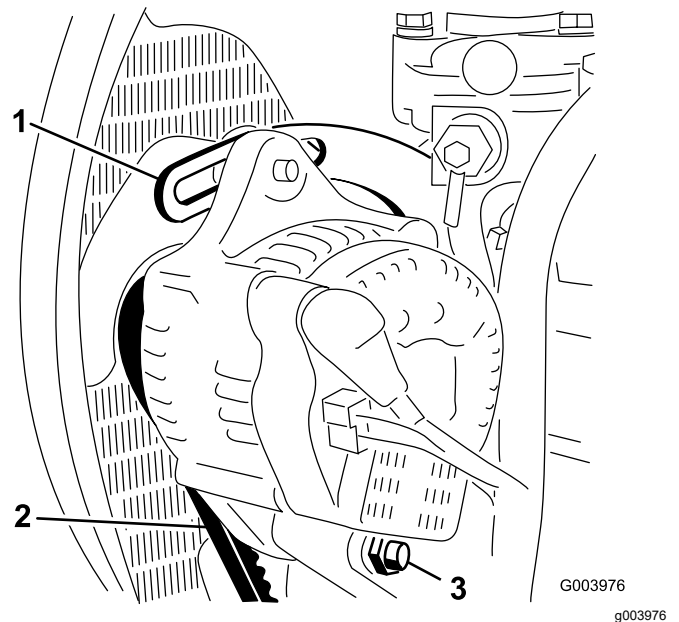

**Figure 115**

1. Brace
2. Alternator belt
3. Pivot bolt

4. Loosen the bolt securing the alternator to the brace, and the alternator pivot bolt. ([Figure 115](#))
5. Insert a pry bar between the alternator and the engine and move the alternator outward.
6. When the belt is tensioned as described in step 3, tighten the bolts securing the alternator to the brace, and the alternator pivot bolt.
7. Close and latch the hood; refer to [Closing the Hood \(page 43\)](#).



# Hydraulic System Maintenance

## Hydraulic System Safety

- Seek immediate medical attention if fluid is injected into skin. Injected fluid must be surgically removed within a few hours by a doctor.
- Ensure that all hydraulic-fluid hoses and lines are in good condition and all hydraulic connections and fittings are tight before applying pressure to the hydraulic system.
- Keep your body and hands away from pinhole leaks or nozzles that eject high-pressure hydraulic fluid.
- Use cardboard or paper to find hydraulic leaks.
- Safely relieve all pressure in the hydraulic system before performing any work on the hydraulic system.

## Hydraulic Fluid Specification

The reservoir is filled at the factory with high-quality hydraulic fluid. Check the level of the hydraulic fluid before you first start the engine and daily thereafter; refer to [Checking the Hydraulic-Fluid Level \(page 67\)](#).

**Recommended hydraulic fluid:** Toro PX Extended Life Hydraulic Fluid; available in 19 L (5 US gallon) pails or 208 L (55 US gallon) drums.

**Note:** A machine using the recommended replacement fluid requires less frequent fluid and filter changes.

**Alternative hydraulic fluids:** If Toro PX Extended Life Hydraulic Fluid is not available, you may use another conventional, petroleum-based hydraulic fluid having specifications that fall within the listed range for all the following material properties and that it meets industry standards. Do not use synthetic fluid. Consult with your lubricant distributor to identify a satisfactory product.

**Note:** Toro does not assume responsibility for damage caused by improper substitutions, so use products only from reputable manufacturers who will stand behind their recommendation.

## High Viscosity Index/Low Pour Point Anti-wear Hydraulic Fluid, ISO VG 46

Material Properties:

Viscosity, ASTM D445                      cSt @ 40°C (104°F)  
44 to 48

## High Viscosity Index/Low Pour Point Anti-wear Hydraulic Fluid, ISO VG 46 (cont'd.)

Viscosity Index ASTM D2270	140 or higher
Pour Point, ASTM D97	-37°C to -45°C (-34°F to -49°F)
Industry Specifications:	Eaton Vickers 694 (I-286-S, M-2950-S/35VQ25 or M-2952-S)

**Note:** Many hydraulic fluids are almost colorless, making it difficult to spot leaks. A red dye additive for the hydraulic fluid is available in 20 ml (0.67 fl oz) bottles. A bottle is sufficient for 15 to 22 L (4 to 6 US gallons) of hydraulic fluid. Order Part No. 44-2500 from your authorized Toro distributor.

**Important:** Toro Premium Synthetic Biodegradable Hydraulic Fluid is the only synthetic biodegradable fluid approved by Toro. This fluid is compatible with the elastomers used in Toro hydraulic systems and is suitable for a wide-range of temperature conditions. This fluid is compatible with conventional mineral oils, but for maximum biodegradability and performance, the hydraulic system should be thoroughly flushed of conventional fluid. Toro Premium Synthetic Biodegradable Hydraulic Fluid is available from your authorized Toro distributor in 19 L (5 US gallon) pails or 208 L (55 US gallon) drums.

## Checking the Hydraulic-Fluid Level

**Service Interval:** Before each use or daily

The reservoir is filled at the factory with high-quality hydraulic fluid. The best time to check the hydraulic oil is when the fluid is cold. The machine should be in its transport configuration.

1. Prepare the machine for maintenance; refer to [Preparing for Maintenance \(page 43\)](#).
2. Clean the area around the filler neck and the cap of the hydraulic tank ([Figure 116](#)).



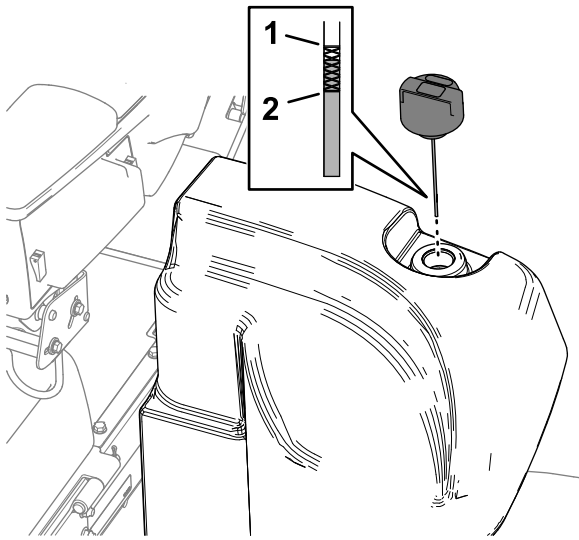

**Figure 116**

g376007

1. Full mark (dipstick)
2. Add mark (dipstick)

3. Remove the cap/dipstick from the filler neck and wipe it with a clean rag.
4. Insert the dipstick into the filler neck; then remove it and check the level of fluid.

**Note:** The fluid level should be within operating range on the dipstick.

**Important:** Do not overfill the tank.

5. If the level is low, add the appropriate amount of fluid to raise the level to the full mark.
6. Install the cap/dipstick onto the filler neck.

## Checking the Hydraulic Lines and Hoses

**Service Interval:** Before each use or daily

Check the hydraulic lines and hoses for leaks, kinked lines, loose mounting supports, wear, loose fittings, weather deterioration, and chemical deterioration. Make all necessary repairs before operating.

## Changing the Charge Filter

**Service Interval:** Every 1,000 hours—If you are using the recommended hydraulic fluid, replace the charge filter.

Every 800 hours—If you are not using the recommended hydraulic fluid or have ever filled the reservoir with an alternative fluid, replace the charge filter.

**Important:** Use of any other filters may void the warranty on some components.

1. Prepare the machine for maintenance; refer to [Preparing for Maintenance \(page 43\)](#).
2. Tilt the seat; refer to [Tilting the Seat \(page 44\)](#).
3. At the left side of the machine, align a drain pan under the charge filter ([Figure 117](#)).

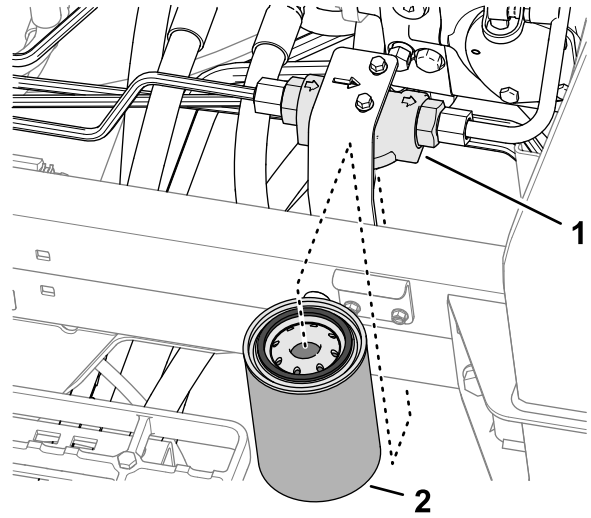

**Figure 117**

g376339

1. Filter head
2. Charge filter

4. Remove the filter.
5. Wipe clean the filter mounting area of the filter head.
6. Apply a thin coat of the specified hydraulic fluid to the gasket of the new charge filter.
7. Thread the filter onto the filter head by hand until the gasket contacts the mounting surface, then rotate the filter an additional 1/2 turn.
8. Lower and latch the seat; refer to [Lowering the Seat \(page 44\)](#).

## Checking for Leaks

1. Start the engine and run it for 2 minutes to purge air from the hydraulic system.
2. Shut off the engine, remove the key, and check for leaks at the return and charge filters.

**Note:** Repair all hydraulic leaks.

## Hydraulic Fluid Capacity

41.6 L (11 US gallons); refer to [Hydraulic Fluid Specification \(page 67\)](#)

# Changing the Hydraulic Fluid

**Service Interval:** Every 2,000 hours—**If you are using the recommended hydraulic fluid**, change the hydraulic fluid.

Every 800 hours—**If you are not using the recommended hydraulic fluid or have ever filled the reservoir with an alternative fluid**, change the hydraulic fluid.

If the fluid becomes contaminated, contact your Toro Distributor because the system must be flushed. Contaminated fluid looks milky or black when compared to clean fluid.

1. Prepare the machine for maintenance; refer to [Preparing for Maintenance \(page 43\)](#).
2. Place a large drain pan under the 90° fitting (Figure 118) of the hydraulic tank; refer to [Hydraulic Fluid Capacity \(page 68\)](#).

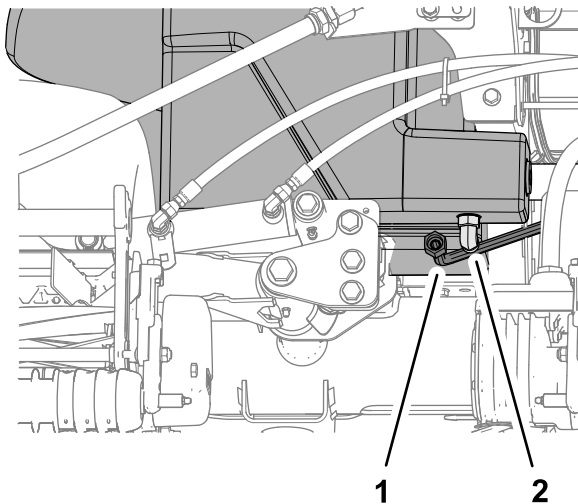

**Figure 118**

g379100

1. 90° fitting (hydraulic tank)
  2. Tube (cooler return)
- 
3. Disconnect the cooler-return tube from the 90° fitting, and allow the tank to drain.
  4. When hydraulic fluid stops draining from the tank, install the tube.
  5. Fill the tank with the specified hydraulic fluid; refer to [Hydraulic Fluid Specification \(page 67\)](#) and [Hydraulic Fluid Capacity \(page 68\)](#).
- Important:** Use only the hydraulic fluids specified. Other fluids could cause system damage.
6. Install the tank cap.
  7. Start the engine, and use all the hydraulic controls to distribute hydraulic fluid throughout the system.

8. Check for hydraulic-fluid leaks; refer to [Checking for Leaks \(page 68\)](#).
9. Check the level; refer to [Checking the Hydraulic-Fluid Level \(page 67\)](#)

# Cutting Unit System Maintenance

## Blade Safety

A worn or damaged blade or bedknife can break, and a piece could be thrown toward you or bystanders, resulting in serious personal injury or death.

- Inspect the blades and bedknives periodically for excessive wear or damage.
- Use care when checking the blades. Wear gloves and use caution when servicing them. Only replace or backlap the blades and bedknives; never straighten or weld them.
- On machines with multiple cutting units, take care when rotating a cutting unit; it can cause the reels in the other cutting units to rotate.

## Checking the Reel-to-Bedknife Contact

**Service Interval:** Before each use or daily

Each day before operating, check the reel-to-bedknife contact, regardless if the quality of cut had previously been acceptable. There must be light contact across the full length of the reel and the bedknife (refer to Adjusting the Reel to Bedknife in the cutting unit *Operator's Manual*).

## Backlapping the Cutting Units

### ▲ WARNING

Contact with the cutting units or other moving parts can result in personal injury.

- **Keep your fingers, hands, and clothing away from the cutting units and other moving parts.**
- **Never attempt to turn the cutting units by hand or foot while the engine is running.**

**Note:** Additional instructions and procedures on backlapping are available in the Toro Reel Mower Basics (with sharpening guidelines), Form 09168SL.

**Note:** When backlapping, the front units all operate together, and the rear units operate together.

## Preparing the Machine

1. Prepare the machine for maintenance; refer to [Preparing for Maintenance \(page 43\)](#).
2. With the engine off, but the key in the run position, access the Main Menu of the InfoCenter.
3. From the Main Menu, scroll down to Service Menu using the center button and select it using the right button.
4. In the Service Menu, scroll down to Front Backlap, Rear Backlap, and activate front, rear or both by using the right button to turn the desired set of cutting units from OFF to ON.
5. Press the left button to save the settings and exit the Settings menu.
6. Make initial reel-to-bedknife adjustments appropriate for backlapping on all cutting units which are to be backlapped; refer to the cutting unit *Operator's Manual*.

## Lapping the Reels and Bedknife

1. Start the engine and run at low idle speed.

### ▲ DANGER

**Changing the engine speed while backlapping may cause the reels to stall.**

- **Never change the engine speed while backlapping.**
- **Only backlap at idle engine speed.**

2. With the Mow/Transport lever in the MOW position, move the Enable/Disable switch to the ENABLE position. Move the Lower Mow/Lift control forward to start the backlapping operation on the designated reels.
3. Apply lapping compound with a long-handled brush.

**Important:** Never use a short-handled brush.

4. If the reels stall or become erratic while backlapping, select a higher reel speed setting until the speed stabilizes, then return the reel speed to your desired speed. This can be done using the buttons on the InfoCenter.
5. If you need to make an adjustment to the cutting units while backlapping, perform the following steps:
  - A. Moving the Lower Mow/Raise lever rearward and press the Enable/Disable switch to DISABLE position.
  - B. Shut off the engine and remove the key.
  - C. Adjust to the cutting units.

- D. Repeat steps 1 through 3.
6. Repeat step 3 for the other cutting units that you want to backlap.

## Finishing Backlapping

1. Moving the Lower Mow/Raise lever rearward and press the Enable/Disable switch to DISABLE position.
2. Shut off the backlap functions using the buttons in the InfoCenter.

**Important:** If you do not return the backlap function to the OFF setting after backlapping, the cutting units do not raise or function properly.

3. Shut off the engine and remove the key.
4. Wash all lapping compound off from the cutting units.
5. For a better cutting edge, run a file across the front face of the bedknife after lapping.

**Note:** Burrs or rough edges may result from lapping the cutting edge. For a better cutting edge, file across the cutting edge 90° to the front face of the bedknife to remove the burrs.

6. Adjust the cutting unit reel to bedknife as needed.
7. Adjust the cutting unit reel speed to the desired mowing setting.

# Chassis Maintenance

## Inspecting the Seat Belt

**Service Interval:** Before each use or daily

1. Inspect the seat belt for wear, cuts, and other damage. Replace the seat belt(s) if any component does not operate properly.
2. Clean the seat belt as necessary.

# ***Extended Maintenance***

## **Chassis and Engine**

**Service Interval:** Every 2 years—Replace the hydraulic hoses.

Every 2 years—Replace the coolant hoses.

Every 2 years—Flush and replace the coolant.

# ***Cleaning***

## **Washing the Machine**

Wash the machine as needed using water alone or with a mild detergent. You may use a rag when washing the machine.

***Important:*** Do not use brackish or reclaimed water to clean the machine.

***Important:*** Do not use power-washing equipment to wash the machine. Power-washing equipment may damage the electrical system, loosen important decals, or wash away necessary grease at friction points. Avoid excessive use of water near the control panel, engine, and battery.

***Important:*** Do not wash the machine with the engine running. Doing so may result in internal engine damage.

# Storage

## Storage Safety

- Before you leave the operator's position, do the following:
  - Park the machine on a level surface.
  - Disengage and lower the cutting units.
  - Engage the parking brake.
  - Shut off the engine and remove the key.
  - Wait for all movement to stop.
  - Allow the machine to cool before adjusting, servicing, cleaning, or storing it.
- Do not store the machine or fuel container where there is an open flame, spark, or pilot light, such as on a water heater or other appliance.

## Preparing the Traction Unit

1. Park the machine on a level surface, lower the cutting units, engage the parking brake, shut off the engine, and remove the key.
2. Thoroughly clean the traction unit, cutting units, and the engine.
3. Check the tire pressure; refer to [Checking the Tire Air Pressure \(page 61\)](#).
4. Check all fasteners for looseness; tighten them as necessary.
5. Grease or oil all grease fittings and pivot points. Wipe up any excess lubricant.
6. Lightly sand and use touch-up paint on painted areas that are scratched, chipped, or rusted. Repair any dents in the metal body.
7. Service the battery and cables as follows; refer to [Electrical System Safety \(page 56\)](#):
  - A. Remove the battery terminals from the battery posts.
  - B. Clean the battery, terminals, and posts with a wire brush and baking-soda solution.
  - C. Coat the cable terminals and battery posts with Grafo 112X skin-over grease (Toro Part No. 505-47) or petroleum jelly to prevent corrosion.
  - D. Slowly charge the battery every 60 days for 24 hours to prevent lead sulfation of the battery.

## Preparing the Engine

1. Drain the engine oil from the oil pan and install the drain plug.
2. Remove and discard the oil filter. Install a new oil filter.
3. Fill the engine with specified motor oil.
4. Start the engine and run it at idle speed for approximately 2 minutes.
5. Shut off the engine and remove the key.
6. Flush the fuel tank with fresh, clean fuel.
7. Secure all of the fuel-system fittings.
8. Thoroughly clean and service the air-cleaner assembly.
9. Seal the air-cleaner inlet and the exhaust outlet with weatherproof tape.
10. Check the antifreeze protection and add a 50/50 solution of water and ethylene glycol antifreeze as needed for the expected minimum temperature in your area.

## Storing the Battery

If you are storing the machine for more than 30 days, remove the battery and charge it fully. Store it either on the shelf or on the machine. Leave the cables disconnected if they are stored on the machine. Store the battery in a cool atmosphere to avoid quick deterioration of the charge in the battery. To prevent the battery from freezing, ensure that it is fully charged. The specific gravity of a fully charged battery is 1.265 to 1.299.

**Notes:**



## EEA/UK Privacy Notice

### **Toro's Use of Your Personal Information**

The Toro Company ("Toro") respects your privacy. When you purchase our products, we may collect certain personal information about you, either directly from you or through your local Toro company or dealer. Toro uses this information to fulfil contractual obligations - such as to register your warranty, process your warranty claim or to contact you in the event of a product recall - and for legitimate business purposes - such as to gauge customer satisfaction, improve our products or provide you with product information which may be of interest. Toro may share your information with our subsidiaries, affiliates, dealers or other business partners in connection these activities. We may also disclose personal information when required by law or in connection with the sale, purchase or merger of a business. We will never sell your personal information to any other company for marketing purposes.

### **Retention of your Personal Information**

Toro will keep your personal information as long as it is relevant for the above purposes and in accordance with legal requirements. For more information about applicable retention periods please contact [legal@toro.com](mailto:legal@toro.com).

### **Toro's Commitment to Security**

Your personal information may be processed in the US or another country which may have less strict data protection laws than your country of residence. Whenever we transfer your information outside of your country of residence, we will take legally required steps to ensure that appropriate safeguards are in place to protect your information and to make sure it is treated securely.

### **Access and Correction**

You may have the right to correct or review your personal data, or object to or restrict the processing of your data. To do so, please contact us by email at [legal@toro.com](mailto:legal@toro.com). If you have concerns about the way in which Toro has handled your information, we encourage you to raise this directly with us. Please note that European residents have the right to complain to your Data Protection Authority.



# The Toro Warranty

Two-Year or 1,500 Hours Limited Warranty

## Conditions and Products Covered

The Toro Company warrants your Toro Commercial product ("Product") to be free from defects in materials or workmanship for 2 years or 1,500 operational hours\*, whichever occurs first. This warranty is applicable to all products with the exception of Aerators (refer to separate warranty statements for these products). Where a warrantable condition exists, we will repair the Product at no cost to you including diagnostics, labor, parts, and transportation. This warranty begins on the date the Product is delivered to the original retail purchaser.

\* Product equipped with an hour meter.

## Instructions for Obtaining Warranty Service

You are responsible for notifying the Commercial Products Distributor or Authorized Commercial Products Dealer from whom you purchased the Product as soon as you believe a warrantable condition exists. If you need help locating a Commercial Products Distributor or Authorized Dealer, or if you have questions regarding your warranty rights or responsibilities, you may contact us at:

Toro Commercial Products Service Department  
8111 Lyndale Avenue South  
Bloomington, MN 55420-1196

952-888-8801 or 800-952-2740  
E-mail: [commercial.warranty@toro.com](mailto:commercial.warranty@toro.com)

## Owner Responsibilities

As the product owner, you are responsible for required maintenance and adjustments stated in your *Operator's Manual*. Repairs for product issues caused by failure to perform required maintenance and adjustments are not covered under this warranty.

## Items and Conditions Not Covered

Not all product failures or malfunctions that occur during the warranty period are defects in materials or workmanship. This warranty does not cover the following:

- Product failures which result from the use of non-Toro replacement parts, or from installation and use of add-on, or modified non-Toro branded accessories and products.
- Product failures which result from failure to perform recommended maintenance and/or adjustments.
- Product failures which result from operating the Product in an abusive, negligent, or reckless manner.
- Parts consumed through use that are not defective. Examples of parts which are consumed, or used up, during normal Product operation include, but are not limited to, brake pads and linings, clutch linings, blades, reels, rollers and bearings (sealed or greasable), bed knives, spark plugs, castor wheels and bearings, tires, filters, belts, and certain sprayer components such as diaphragms, nozzles, flow meters, and check valves.
- Failures caused by outside influence, including, but not limited to, weather, storage practices, contamination, use of unapproved fuels, coolants, lubricants, additives, fertilizers, water, or chemicals.
- Failure or performance issues due to the use of fuels (e.g. gasoline, diesel, or biodiesel) that do not conform to their respective industry standards.
- Normal noise, vibration, wear and tear, and deterioration. Normal "wear and tear" includes, but is not limited to, damage to seats due to wear or abrasion, worn painted surfaces, scratched decals or windows.

## Countries Other than the United States or Canada

Customers who have purchased Toro products exported from the United States or Canada should contact their Toro Distributor (Dealer) to obtain guarantee policies for your country, province, or state. If for any reason you are dissatisfied with your Distributor's service or have difficulty obtaining guarantee information, contact your Authorized Toro Service Center.

## Parts

Parts scheduled for replacement as required maintenance are warranted for the period of time up to the scheduled replacement time for that part. Parts replaced under this warranty are covered for the duration of the original product warranty and become the property of Toro. Toro will make the final decision whether to repair any existing part or assembly or replace it. Toro may use remanufactured parts for warranty repairs.

## Deep Cycle and Lithium-Ion Battery Warranty

Deep cycle and Lithium-Ion batteries have a specified total number of kilowatt-hours they can deliver during their lifetime. Operating, recharging, and maintenance techniques can extend or reduce total battery life. As the batteries in this product are consumed, the amount of useful work between charging intervals will slowly decrease until the battery is completely worn out. Replacement of worn out batteries, due to normal consumption, is the responsibility of the product owner. Note: (Lithium-Ion battery only): Refer to the battery warranty for additional information.

## Lifetime Crankshaft Warranty (ProStripe 02657 Model Only)

The ProStripe which is fitted with a genuine Toro Friction Disc and Crank-Safe Blade Brake Clutch (integrated Blade Brake Clutch (BBC) + Friction Disc assembly) as original equipment and used by the original purchaser in accordance with recommended operating and maintenance procedures, are covered by a Lifetime Warranty against engine crankshaft bending. Machines fitted with friction washers, Blade Brake Clutch (BBC) units and other such devices are not covered by the Lifetime Crankshaft Warranty.

## Maintenance is at Owner's Expense

Engine tune-up, lubrication, cleaning and polishing, replacement of filters, coolant, and completing recommended maintenance are some of the normal services Toro products require that are at the owner's expense.

## General Conditions

Repair by an Authorized Toro Distributor or Dealer is your sole remedy under this warranty.

**The Toro Company is not liable for indirect, incidental or consequential damages in connection with the use of the Toro Products covered by this warranty, including any cost or expense of providing substitute equipment or service during reasonable periods of malfunction or non-use pending completion of repairs under this warranty. Except for the Emissions warranty referenced below, if applicable, there is no other express warranty. All implied warranties of merchantability and fitness for use are limited to the duration of this express warranty.**

Some states do not allow exclusions of incidental or consequential damages, or limitations on how long an implied warranty lasts, so the above exclusions and limitations may not apply to you. This warranty gives you specific legal rights, and you may also have other rights which vary from state to state.

## Note Regarding Emissions Warranty

The Emissions Control System on your Product may be covered by a separate warranty meeting requirements established by the U.S. Environmental Protection Agency (EPA) and/or the California Air Resources Board (CARB). The hour limitations set forth above do not apply to the Emissions Control System Warranty. Refer to the Engine Emission Control Warranty Statement supplied with your product or contained in the engine manufacturer's documentation.