



Count on it.

Form No. 3453-435 Rev A

Operator's Manual

Groundsmaster® 4300-D Traction Unit

Model No. 30864—Serial No. 412437987 and Up



This product complies with all relevant European directives; for details, please see the separate product specific Declaration of Conformity (DOC) sheet.

It is a violation of California Public Resource Code Section 4442 or 4443 to use or operate the engine on any forest-covered, brush-covered, or grass-covered land unless the engine is equipped with a spark arrester, as defined in Section 4442, maintained in effective working order or the engine is constructed, equipped, and maintained for the prevention of fire.

The enclosed engine owner's manual is supplied for information regarding the US Environmental Protection Agency (EPA) and the California Emission Control Regulation of emission systems, maintenance, and warranty. Replacements may be ordered through the engine manufacturer.

⚠ WARNING

**CALIFORNIA
Proposition 65 Warning**

Diesel engine exhaust and some of its constituents are known to the State of California to cause cancer, birth defects, and other reproductive harm.

Battery posts, terminals, and related accessories contain lead and lead compounds, chemicals known to the State of California to cause cancer and reproductive harm. Wash hands after handling.

Use of this product may cause exposure to chemicals known to the State of California to cause cancer, birth defects, or other reproductive harm.

Introduction

This machine is a ride-on, rotary-blade lawn mower intended to be used by professional, hired operators in commercial applications. It is primarily designed for cutting grass on well-maintained lawns in parks, sports fields, and on commercial grounds. Using this product for purposes other than its intended use could prove dangerous to you and bystanders.

Read this information carefully to learn how to operate and maintain your product properly and to avoid injury and product damage. You are responsible for operating the product properly and safely.

Visit www.Toro.com for product safety and operation training materials, accessory information, help finding a dealer, or to register your product.

Whenever you need service, genuine Toro parts, or additional information, contact an Authorized Service Dealer or Toro Customer Service and have the model and serial numbers of your product ready. **Figure 1** identifies the location of the model and serial numbers on the product. Write the numbers in the space provided.

Important: With your mobile device, you can scan the QR code on the serial number decal (if equipped) to access warranty, parts, and other product information.

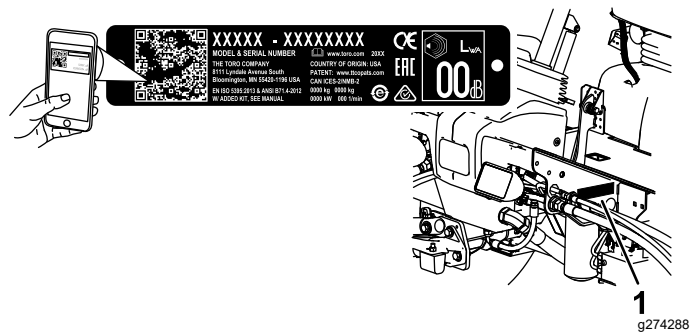

Figure 1

1. Serial number

Model No. _____

Serial No. _____

This manual identifies potential hazards and has safety messages identified by the safety-alert symbol (**Figure 2**), which signals a hazard that may cause serious injury or death if you do not follow the recommended precautions.



Figure 2

1. Safety-alert symbol

This manual uses 2 words to highlight information. **Important** calls attention to special mechanical information and **Note** emphasizes general information worthy of special attention.

Contents

Safety	4	Lubrication	51
General Safety	4	Greasing the Bearings and Bushings	51
Safety and Instructional Decals	5	Engine Maintenance	53
Setup	10	Engine Safety	53
1 Installing the Decals (CE Machines Only)	10	Servicing the Air Cleaner	53
2 Adjusting the Control Arm Position	11	Servicing the Engine Oil	54
3 Removing the Shipping Blocks and Pins	11	Fuel System Maintenance	56
4 Installing the Hood Latch	12	Servicing the Fuel Filter	56
5 Adjusting the Carrier Frame	12	Inspecting the Fuel Lines and Connections	56
6 Adjusting the Roller Scraper	13	Servicing the Fuel-Pickup Tube	56
7 Installing the Mulching Baffle	14	Servicing the Water Separator	56
8 Adjusting the Machine Software	14	Draining the Fuel Tank	57
9 Preparing the Machine	14	Servicing the Diesel-Oxidation Catalyst (DOC) and the Soot Filter	57
Product Overview	15	Priming the Fuel System	57
Controls	15	Electrical System Maintenance	58
Specifications	22	Electrical System Safety	58
Cutting Unit Specifications	23	Servicing the Battery	58
Attachments/Accessories	23	Locating the Fuses	58
Before Operation	24	Charging the Battery	59
Before Operation Safety	24	Drive System Maintenance	59
Filling the Fuel Tank	24	Adjusting the Traction Drive for Neutral	59
Checking the Engine-Oil Level	26	Adjusting the Rear Wheel Toe-in	60
Checking the Cooling System	26	Cooling System Maintenance	60
Checking the Hydraulic System	26	Cooling System Safety	60
Draining the Water Separator	26	Coolant Specification	60
Checking the Tire Pressure	26	Checking the Cooling System	61
Checking the Torque of the Wheel-Lug Nuts	26	Cleaning the Cooling System	61
Adjusting the Height of Cut	27	Brake Maintenance	62
Checking the Safety-Interlock Switches	28	Adjusting the Parking Brakes	62
Checking the Blade Stopping Time	28	Adjusting the Parking-Brake Latch	63
Burnishing the Brakes	28	Belt Maintenance	63
Selecting a Blade	28	Servicing the Alternator Belt	63
Understanding the Diagnostic Light	29	Hydraulic System Maintenance	64
Changing the Counterbalance Settings	29	Hydraulic System Safety	64
Choosing Accessories	30	Servicing the Hydraulic Fluid	64
During Operation	31	Checking the Hydraulic Lines and Hoses	67
During Operation Safety	31	Testing the Hydraulic-System Pressure	67
Starting the Engine	32	Hydraulic Valve Solenoid Functions	67
Shutting Off the Engine	32	Cutting Unit Maintenance	67
Cutting Grass with the Machine	32	Separating the Cutting Unit from the Traction Unit	67
Diesel Particulate Filter Regeneration	33	Mounting the Cutting Units to the Traction Unit	68
Operating Tips	45	Servicing the Front Roller	68
After Operation	46	Blade Maintenance	69
General Safety	46	Blade Safety	69
Identifying the Tie-Down Points	46	Servicing the Blade Plane	69
Hauling the Machine	46	Removing and Installing the Cutting-Unit Blade(s)	70
Pushing or Towing the Machine	47	Inspecting and Sharpening the Blade	70
Maintenance	48	Storage	71
Maintenance Safety	48	Storage Safety	71
Recommended Maintenance Schedule(s)	48	Preparing the Machine for Storage	71
Daily Maintenance Checklist	50	Storing the Cutting Units	72
Pre-Maintenance Procedures	51		
Raising the Machine	51		

Safety

This machine has been designed in accordance with EN ISO 5395 (when you complete the setup procedures) and ANSI B71.4-2017.

General Safety

This product is capable of amputating hands and feet and of throwing objects. Always follow all safety instructions to avoid serious personal injury.

- Read and understand the contents of this *Operator's Manual* before starting the engine.
- Use your full attention while operating the machine. Do not engage in any activity that causes distractions; otherwise, injury or property damage may occur.
- Do not operate the machine without all guards and other safety protective devices in place and functioning properly on the machine.
- Keep your hands and feet away from rotating parts. Keep clear of the discharge opening.
- Keep bystanders and children out of the operating area. Never allow children to operate the machine.
- Shut off the engine, remove the key, and wait for all movement to stop before you leave the operator's position. Allow the machine to cool before adjusting, servicing, cleaning, or storing it.

Improperly using or maintaining this machine can result in injury. To reduce the potential for injury, comply with these safety instructions and always pay attention to the safety-alert symbol , which means Caution, Warning, or Danger—personal safety instruction. Failure to comply with these instructions may result in personal injury or death.

Safety and Instructional Decals



Safety decals and instructions are easily visible to the operator and are located near any area of potential danger. Replace any decal that is damaged or missing.

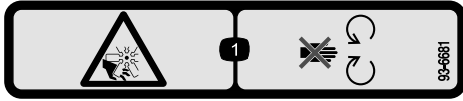

93-6681

decal93-6681

1. Cutting/dismemberment hazard, fan—stay away from moving parts.

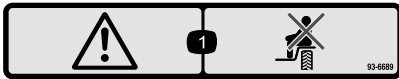

93-6689

decal93-6689

1. Warning—do not carry passengers.

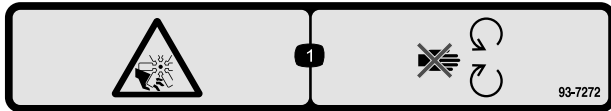

93-7272

decal93-7272

1. Cutting/dismemberment hazard; fan—stay away from moving parts.

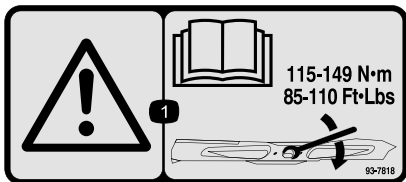

93-7818

decal93-7818

1. Warning—read the *Operator's Manual* for instructions on torquing the blade bolt/nut to 115 to 149 N·m (85 to 110 ft-lb).



106-6754

decal106-6754

1. Warning—do not touch the hot surface.
2. Cutting/dismemberment hazard, fan and entanglement hazard, belt—stay away from moving parts.

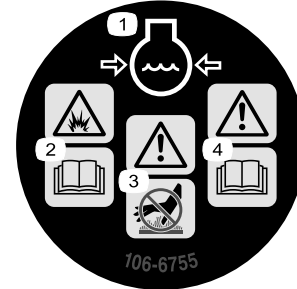

106-6755

decal106-6755

1. Engine coolant under pressure.
2. Explosion hazard—read the *Operator's Manual*.
3. Warning—do not touch the hot surface.
4. Warning—read the *Operator's Manual*.

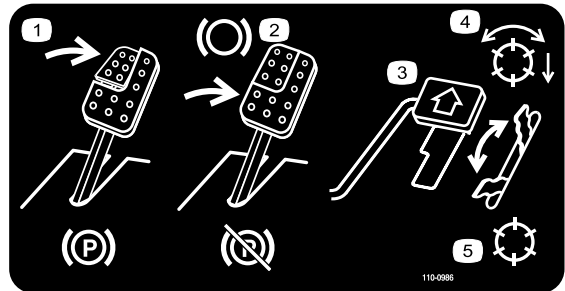

110-0986

decal110-0986

1. Press the brake pedal and parking-brake pedal to engage the parking brake.
2. Press the brake pedal to apply the brake.
3. Press the traction pedal to move the machine forward.
4. PTO enabled mode
5. Transport mode (No PTO)

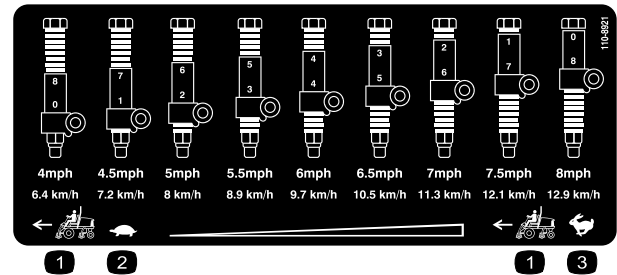

110-8921

decal110-8921

1. Traction unit speed
2. Slow
3. Fast

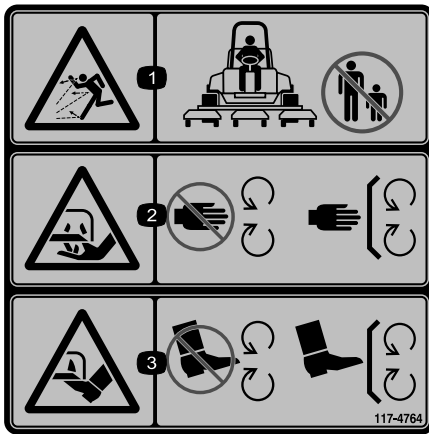

117-4764

decal117-4764

1. Thrown object hazard—keep bystanders out of the operating area.
2. Cutting hazard of hand, mower blade—stay away from moving parts, keep all guards and shields in place.
3. Cutting hazard of foot, mower blade—stay away from moving parts, keep all guards and shields in place.

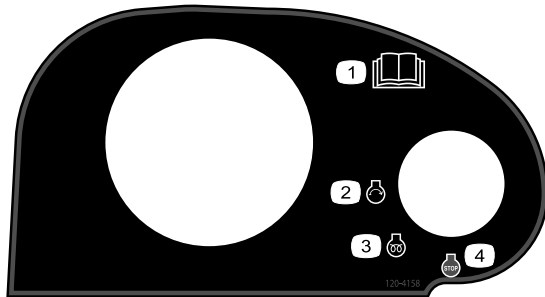

120-4158

decal120-4158

1. Read the *Operator's Manual*.
2. Engine—start
3. Engine—preheat
4. Engine—shut off

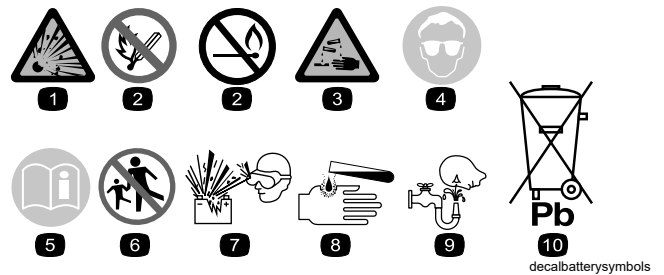

decalbatterysymbols

Battery Symbols

Some or all of these symbols are on your battery.

1. Explosion hazard
2. No fire, open flame, or smoking
3. Caustic liquid/chemical burn hazard
4. Wear eye protection.
5. Read the *Operator's Manual*.
6. Keep bystanders away from the battery.
7. Wear eye protection; explosive gases can cause blindness and other injuries.
8. Battery acid can cause blindness or severe burns.
9. Flush eyes immediately with water and get medical help fast.
10. Contains lead; do not discard



decal133-8062

133-8062

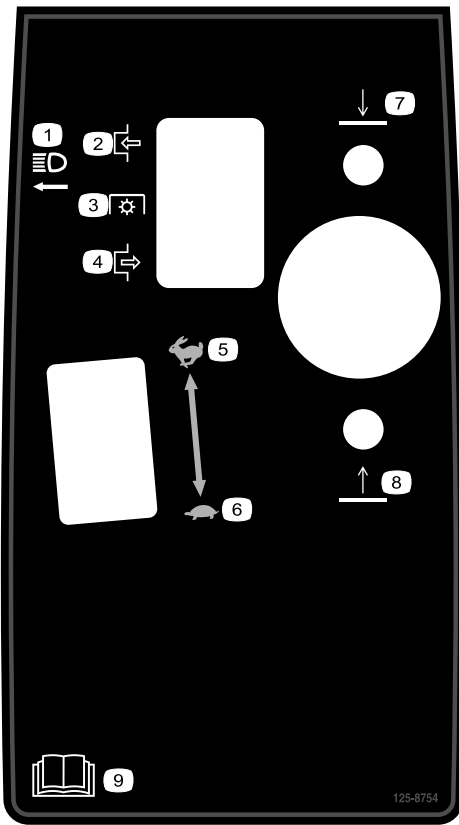

125-8754

decal125-8754

- | | |
|-------------------------|--|
| 1. Head lights | 6. Slow |
| 2. Engage | 7. Lower the cutting units |
| 3. Power take-off (PTO) | 8. Raise the cutting units |
| 4. Disengage | 9. Read the <i>Operator's Manual</i> . |
| 5. Fast | |

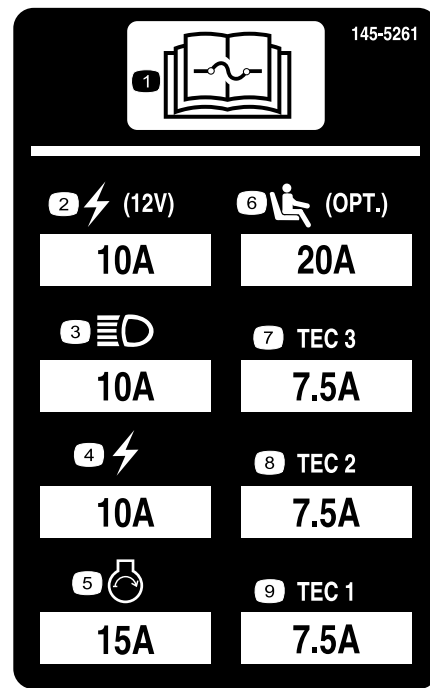

145-5261

decal145-5261

- | | | |
|--|--|----------------------|
| 1. Read the <i>Operator's Manual</i> for fuse information. | 4. Electric | 7. TEC controller |
| 2. Power point (12V) | 5. Engine start | 8. TEC controller V) |
| 3. Headlights | 6. Air ride seat suspension (optional) | 9. TEC controller |

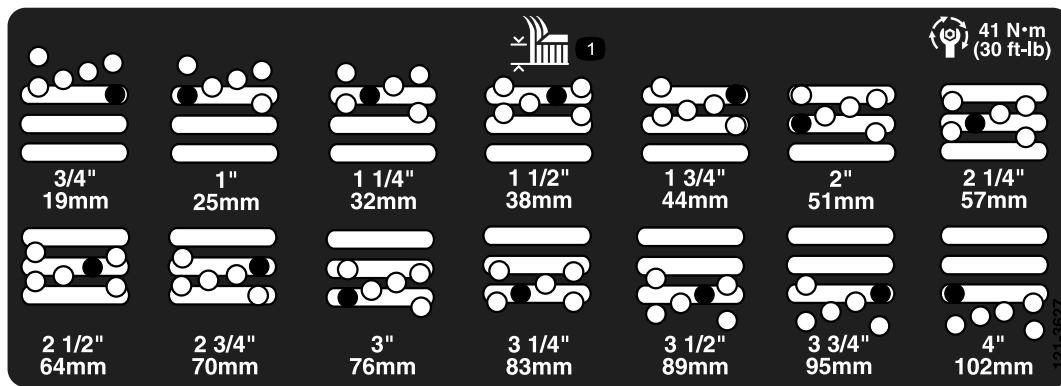

121-3627

decal121-3627

1. Height-of-cut settings

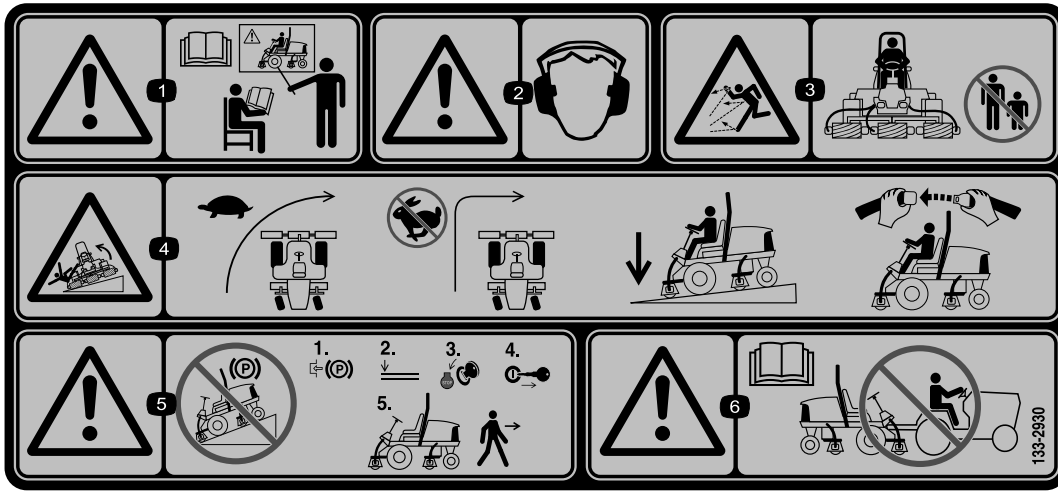

133-2930

decal133-2930

1. Warning—do not operate this machine unless you are trained.
2. Warning—wear hearing protection.
3. Thrown object hazard—keep bystanders out of the operating area.
4. Tipping hazard—drive slowly when turning; do not turn sharply while traveling fast; only drive on slopes with the cutting units lowered; always wear a seatbelt.
5. Warning—do not park on slopes; engage the parking brake, lower the cutting units, shut off the engine, and remove the ignition key before leaving the machine.
6. Warning—read the *Operator's Manual*; do not tow the machine.

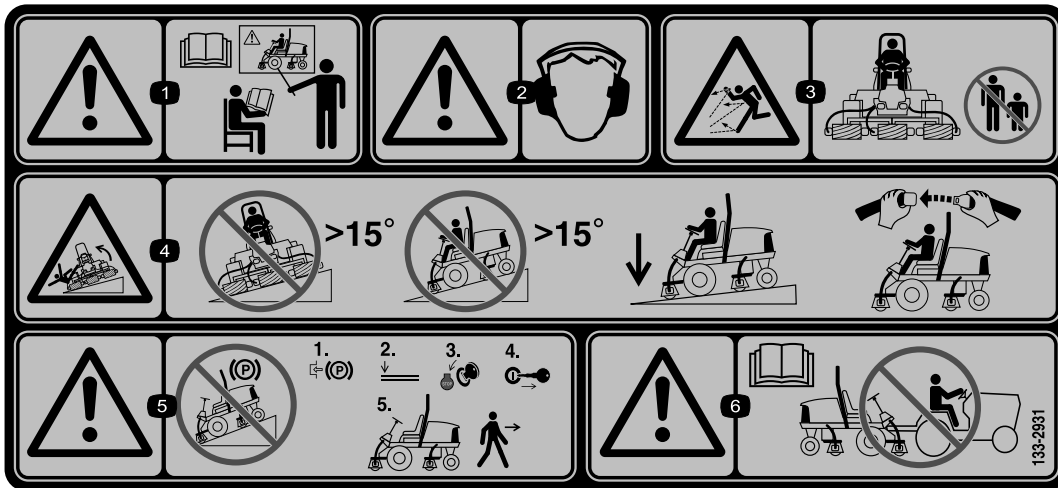

133-2931

decal133-2931

Note: This machine complies with the industry standard stability test in the static lateral and longitudinal tests with the maximum recommended slope indicated on the decal. Review the instructions for operating the machine on slopes in the *Operator's Manual* as well as the conditions in which you would operate the machine to determine whether you can operate the machine in the conditions on that day and at that site. Changes in the terrain can result in a change in slope operation for the machine. If possible, keep the cutting units lowered to the ground while operating the machine on slopes. Raising the cutting units while operating on slopes can cause the machine to become unstable.

1. Warning—read the *Operator's Manual*; do not operate this machine unless you are trained.
2. Warning—wear hearing protection.
3. Thrown object hazard—keep bystanders away.
4. Tipping hazard—do not drive across or down slopes greater than 15°; only drive on slopes with the cutting units lowered; always wear a seatbelt.
5. Warning—do not park on slopes; engage the parking brake, lower the cutting units, shut off the engine, and remove the ignition key before leaving the machine.
6. Warning—read the *Operator's Manual*; do not tow the machine.

REELMASTER 5410-D / 5510-D / 5610-D GROUNDMASTER 4300-D

	16 ●	17 ●	18 ⏰	19 ⏰	
10	SAE 15W-40 C.J-4	5.5 QTS. 5.2 L	250	250	(A) 125-7025
3	14	15 GALS 56.8 L	2000	1000	(B) 94-2621 (B) 86-3010
5				14	(C) 108-3810
12	NO. 2 DIESEL	14 GALS. 53 L	2 YRS	2 YRS	(D) 125-8752
7	50% WATER 50% ETHYL GLYCOL	7.0 QTS. 6.6 L	2 YRS	2 YRS	
15				400	(E) 125-2915

136-3723

decal136-3723

136-3723

- | | | |
|-------------------------|--|-----------------------------|
| 1. Brake functions | 8. Battery | 15. Fuel/Water separator |
| 2. Check every 8 hours. | 9. Radiator screen | 16. Fluids |
| 3. Hydraulic fluid | 10. Engine oil | 17. Capacity |
| 4. Tire pressure | 11. Engine oil level | 18. Fluid interval (hours) |
| 5. Engine air filter | 12. Fuel | 19. Filter interval (hours) |
| 6. Fan belt | 13. Read the <i>Operator's Manual</i> for lubrication information. | |
| 7. Engine coolant | 14. Read the <i>Operator's Manual</i> . | |

Setup

Loose Parts

Use the chart below to verify that all parts have been shipped.

Procedure	Description	Qty.	Use
1	Warning decal CE decal	1 1	Install the decals (CE Machines Only).
2	No parts required	–	Adjust the control arm position.
3	No parts required	–	Remove shipping blocks and pins.
4	Hood-latch assembly Washer	1 1	Install the hood latch (for CE compliance).
5	No parts required	–	Adjust the carrier frame.
6	No parts required	–	Adjust the roller scraper (optional).
7	No parts required	–	Install the mulching baffle (optional).
8	No parts required	–	Adjust the machine software.
9	No parts required	–	Prepare the machine.

Media and Additional Parts

Description	Qty.	Use
Operator's Manual	1	
Engine owner's manual	1	
Declaration of Conformity	1	

Note: Determine the left and right sides of the machine from the normal operating position.

1

Installing the Decals (CE Machines Only)

Parts needed for this procedure:

1	Warning decal
1	CE decal

Procedure

- On machines requiring CE compliance, install the warning decal included in the loose parts over the existing decal (Figure 3).
- Install the CE decal next to the serial number plate on the machine (Figure 3).

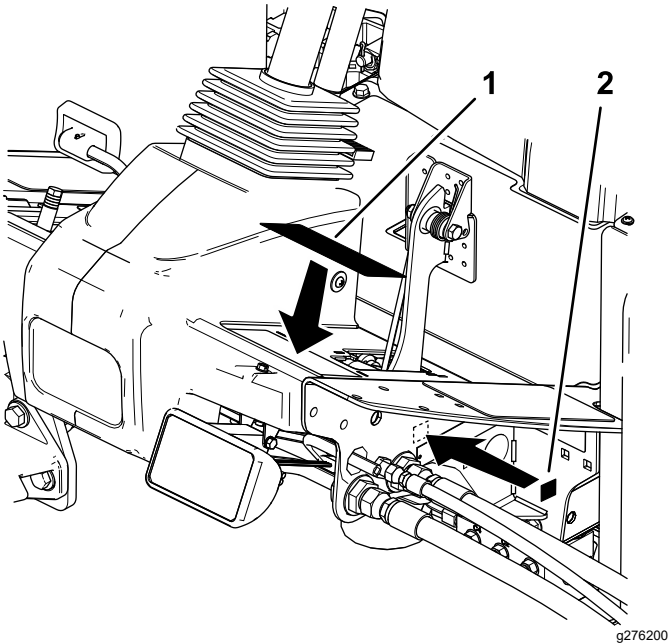

Figure 3

- 1. Warning decal
- 2. CE decal

2

Adjusting the Control Arm Position

No Parts Required

Procedure

You can adjust the control arm position for your comfort.

1. Loosen the 2 bolts securing the control arm to the retaining bracket (Figure 4).

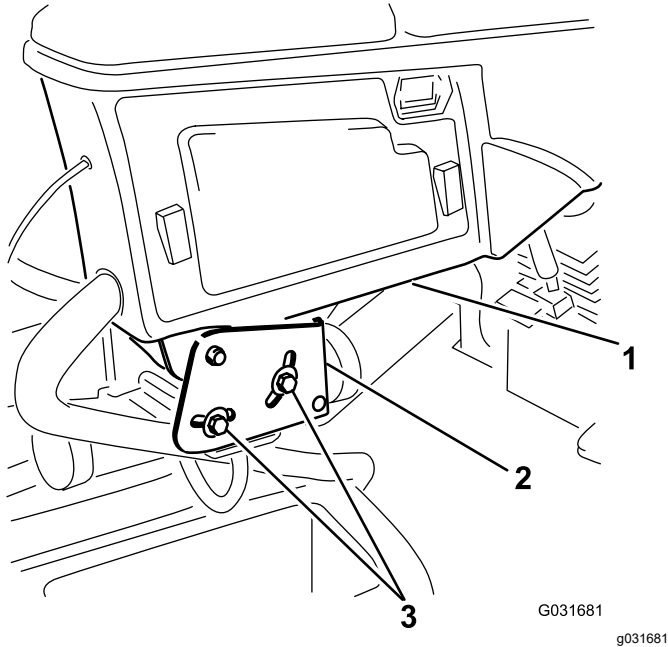

Figure 4

- 1. Control arm
 - 2. Retaining brackets
 - 3. Bolts (2)
2. Rotate the control arm to the desired position and tighten the 2 bolts.

3

Removing the Shipping Blocks and Pins

No Parts Required

Procedure

1. Remove and discard the shipping blocks from the cutting units.
2. Remove and discard the shipping pins from the cutting-unit suspension arms.

Note: The shipping pins stabilize the cutting units during shipping; remove them before operating the machine.

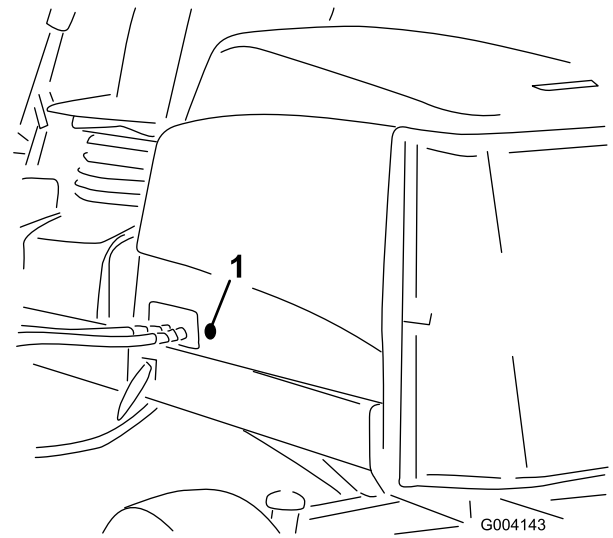

Figure 5

1. Rubber grommet

3. Remove the nut from the hood-latch assembly (Figure 6).

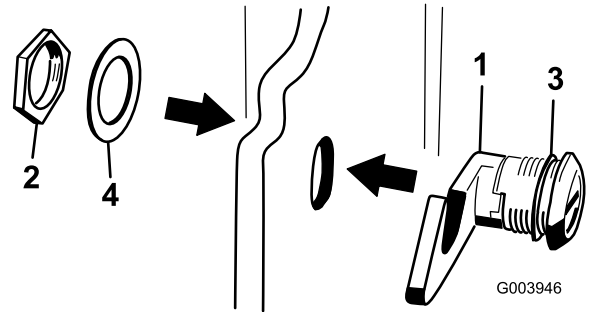

Figure 6

1. Nut
2. Metal washer
3. Hood latch
4. Rubber washer

4

Installing the Hood Latch For CE Compliance

Parts needed for this procedure:

1	Hood-latch assembly
1	Washer

Procedure

1. Unlatch and raise the hood.
2. Remove the rubber grommet from the hole in the left side of the hood (Figure 5).

4. On the outside of the hood, insert the hook end of the latch through the hole in the hood and ensure that the rubber-sealing washer remains to the outer side of the hood (Figure 6).
5. On the inside of the hood, insert the metal washer onto the latch, secure the latch with the nut, and ensure that the latch engages the frame catch when it is locked.

Note: Use the enclosed hood-latch key to operate the hood latch.

5

Adjusting the Carrier Frame

No Parts Required

Adjusting the Front Cutting Units

The front and rear cutting units require different mounting positions. The front cutting unit has 2 mounting positions depending on what height of cut and degree of cutting unit rotation you desire.

- For heights of cut between 2.0 to 7.6 cm (0.75 to 3 inches), mount the front carrier frames in the lower front mounting holes (Figure 7).

Note: This position allows more forward positioning of the cutting units relative to the traction unit when approaching quick uphill changes in terrain. However, it does limit the clearance of the chamber to the carrier when cresting sharp knolls.

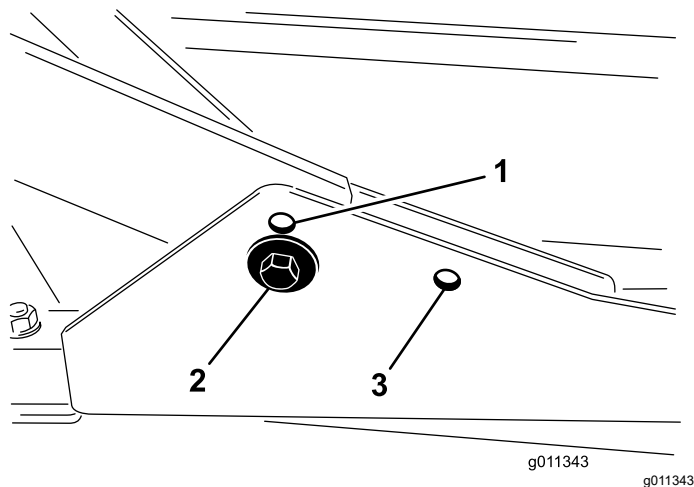

Figure 7

1. Front-cutting-unit mounting hole (upper)
2. Front-cutting-unit mounting hole (lower)
3. Rear-cutting-unit mounting hole

- For heights of cut between 6.3 to 10 cm (2.5 to 4 inches), mount the front carrier frames in the upper front mounting holes (Figure 7).

Note: This increases the chamber to carrier clearance due to the higher position of the cutting chamber, but will cause the cutting units to reach their maximum forward travel sooner.

Adjusting the Rear Cutting Units

The front and rear cutting units require different mounting positions. The rear cutting unit has 1 mounting position for proper alignment with the sidewinder under frame.

For all heights of cut, mount the rear cutting unit in the rear-mounting holes (Figure 7).

6

Adjusting the Roller Scraper

Optional

No Parts Required

Procedure

The optional rear roller scraper functions best when there is an even gap of 0.5 to 1 mm (0.02 to 0.04 inch) between the scraper and the roller.

1. Loosen the grease fitting and the mounting screw (Figure 8).

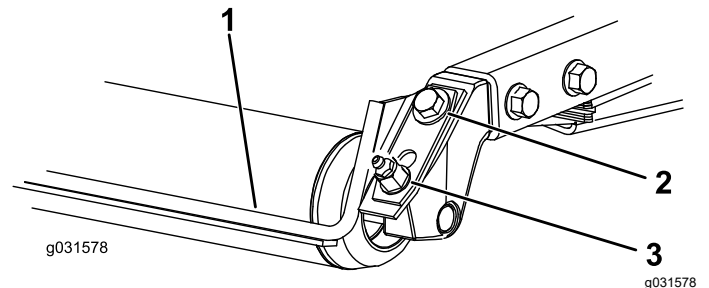

Figure 8

1. Roller scraper
2. Mounting screw
3. Grease fitting

2. Slide the scraper up or down until you obtain a gap of 0.5 to 1 mm (0.02 to 0.04 inch) between the rod and the roller.
3. Tighten the grease fitting and screw to 41 N·m (30 ft-lb) in an alternating sequence.

7

Installing the Mulching Baffle

Optional

No Parts Required

Procedure

Contact your authorized Toro distributor for the correct mulching baffle.

1. Thoroughly clean debris from the mounting holes on the rear wall and left wall of the chamber.
2. Install the mulching baffle in the rear opening and secure it with 5 flange-head bolts (Figure 9).

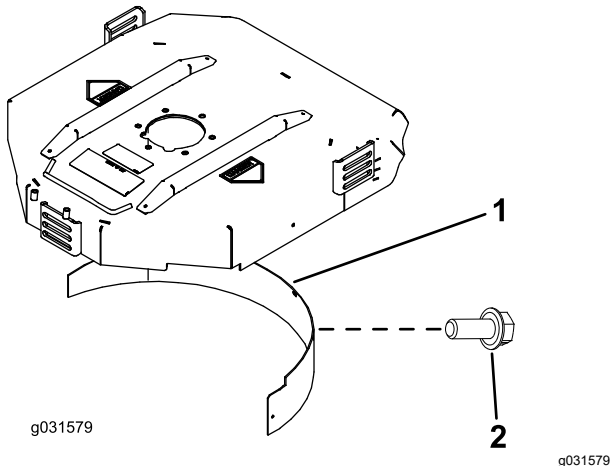

Figure 9

1. Mulching baffle
2. Flange-head bolt

3. Verify that the mulching baffle does not interfere with the tip of the blade and does not protrude inside the surface of the rear chamber wall.

⚠ DANGER

Using the high-lift blade with the mulching baffle could cause the blade to break, resulting in personal injury or death.

Do not use the high-lift blade with the baffle.

8

Adjusting the Machine Software

No Parts Required

Procedure

Contact your authorized Toro distributor to set the machine software to the CE mode.

9

Preparing the Machine

No Parts Required

Checking the Tire Pressure

Check the tire pressure before use; refer to [Checking the Tire Pressure \(page 26\)](#).

Important: Maintain pressure in all tires to ensure a good quality-of-cut and proper machine performance. *Do not underinflate the tires.*

Checking the Fluid Levels

1. Check the engine-oil level before starting the engine; refer to [Checking the Engine-Oil Level \(page 54\)](#).
2. Check the hydraulic-fluid level before starting the engine; refer to [Checking the Hydraulic-Fluid Level \(page 64\)](#).
3. Check the cooling system before starting the engine; refer to [Checking the Cooling System \(page 61\)](#).

Greasing the Machine

Grease the machine before use; refer to [Greasing the Bearings and Bushings \(page 51\)](#). Failure to properly grease the machine results in premature failure of critical parts.

Product Overview

Controls

Traction Pedal

The traction pedal (Figure 10) controls the forward and reverse operation. Press the top of the pedal to move forward and the bottom to move rearward. Ground speed depends on how far you press the pedal. For no load, maximum ground speed, fully press the pedal while the throttle is in the FAST position.

To stop, reduce foot pressure on the traction pedal and allow it to return to the center position.

Mow-Speed Limiter

When the mow-speed limiter (Figure 10) is flipped up it will control the mow speed and allow the cutting decks to be engaged. Each spacer adjusts the mowing speed by 0.8 km/h (0.5 mph). The more spacers you have on the top of the bolt, the slower you will go. For transport, flip back the mow speed limiter for maximum-transport speed.

Brake Pedal

Press the brake pedal (Figure 10) to stop the machine.

Parking Brake

To engage the parking brake, (Figure 10) push down the brake pedal and press the top forward to latch. To disengage the parking brake, press the brake pedal until the parking-brake latch retracts.

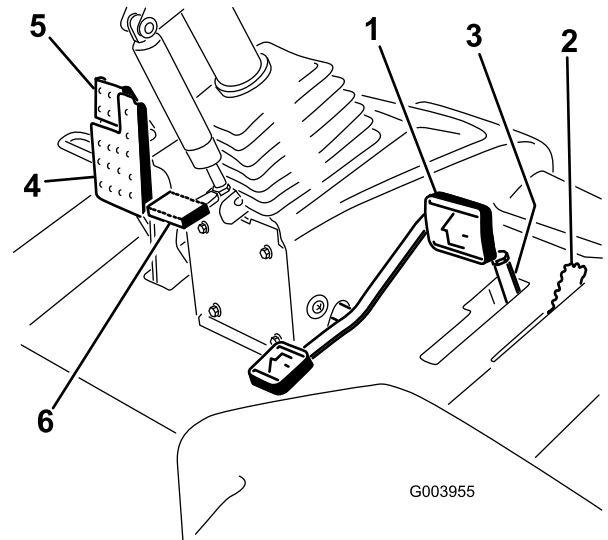

Figure 10

- | | |
|----------------------|------------------------|
| 1. Traction pedal | 4. Brake pedal |
| 2. Mow-speed limiter | 5. Parking brake |
| 3. Spacers | 6. Tilt-steering pedal |

Tilt-Steering Pedal

To tilt the steering wheel toward you, press the foot pedal down, pull the steering tower toward you to the most comfortable position, and release the pedal (Figure 10). To move the steering wheel away from you, press the foot pedal and release it when the steering wheel reaches the desired operating position.

Headlight Switch

Pivot the switch downward to turn on the headlights (Figure 11).

Engine-Speed Switch

The engine-speed switch (Figure 11) has 2 modes to change the engine speed. Tap the switch to increase or decrease the engine speed in 100 rpm increments. Hold the switch down to automatically move the engine to High or Low idle, depending on which end of the switch that you press.

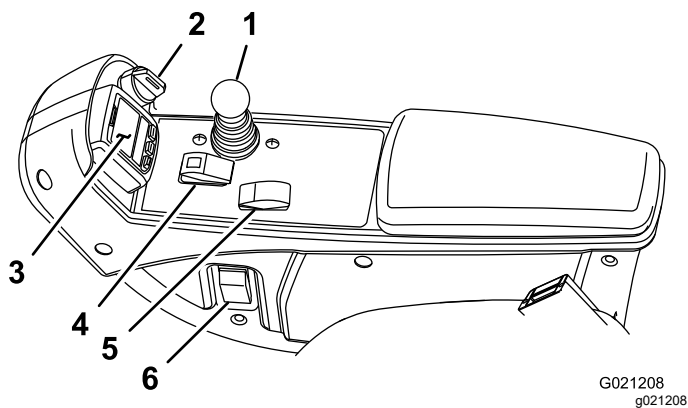

Figure 11

- | | |
|----------------------------------|--------------------------|
| 1. Lower mow/raise control lever | 4. Enable/disable switch |
| 2. Key switch | 5. Engine-speed switch |
| 3. InfoCenter | 6. Headlight switch |

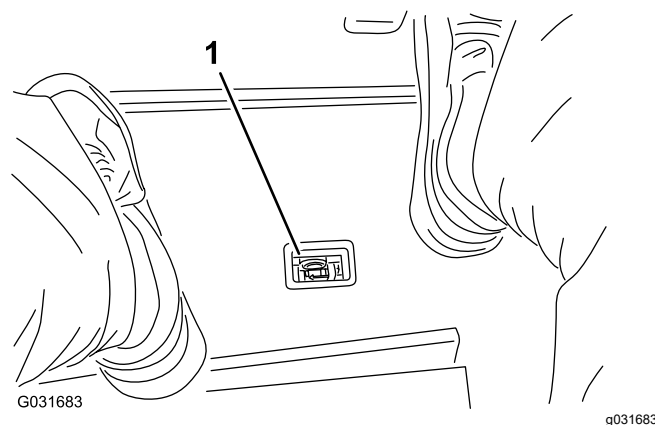

Figure 12

1. Hydraulic-filter-restriction indicator

Key Switch

The key switch (Figure 11) has 3 positions: OFF, ON/PREHEAT, and START.

Lower Mow/Raise Control Lever

The lower mow/raise control lever (Figure 11) raises and lowers the cutting units and also starts and stops the cutting units when the cutting units are enabled in the mow mode. When starting the cutting units in the down position, this lever will turn the cutting units on if the PTO and the mow speed limiter are engaged.

Enable/Disable Switch

Use the enable/disable switch (Figure 11) in conjunction with the lower mow/raise control lever to operate the mowers. The mowers cannot be lowered when the mow/transport lever is in the TRANSPORT position.

Hydraulic-Filter-Restriction Indicator

The hydraulic-filter-restriction indicator alerts you when the hydraulic filters must be changed; refer to [Replacing the Hydraulic Filters \(page 66\)](#).

Power Point

The power point (Figure 13) is a 12 V power supply for electronic devices.

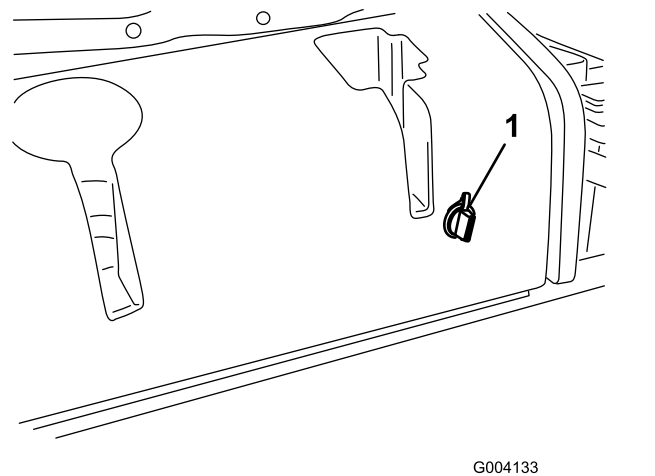

Figure 13

1. Power point

Seat-Adjustment Controls

Refer to Figure 14 for an illustration of the seat-adjustment controls.

- The seat-adjustment lever allows you to adjust the seat forward and rearward.
- The weight-adjusting knob adjusts the seat for your weight.
- The weight gauge indicates when the seat is adjusted to your weight.
- The height-adjusting knob adjusts the seat for your height.

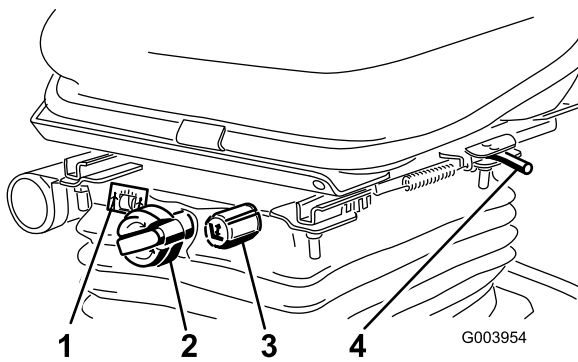

Figure 14

- | | |
|--------------------------|--|
| 1. Weight gauge | 3. Height-adjusting knob |
| 2. Weight-adjusting knob | 4. Seat-adjustment lever
(forward and rearward) |

- Middle Button—use this button to scroll down menus.
- Right Button—use this button to open a menu where a right arrow indicates additional content.
- Beeper—activated when lowering the cutting units or for advisories and faults.

Note: The purpose of each button may change depending on what is required at the time. Each button is labeled with an icon displaying its current function.

InfoCenter

The InfoCenter LCD display shows the operating status, various diagnostics, and other information about the machine (Figure 15).

Using the InfoCenter LCD Display

The InfoCenter LCD display shows information about your machine, such as the operating status, various diagnostics and other information about the machine (Figure 15). There is a splash screen and main information screen of the InfoCenter. You can switch between the splash screen and main information screen at any time by pressing any of the InfoCenter buttons and then selecting the appropriate directional arrow.

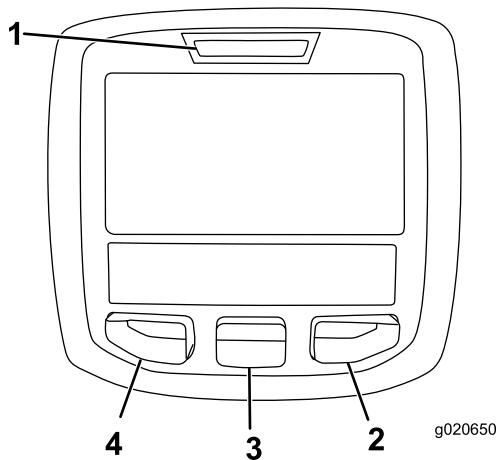























Figure 15













- | | |
|--------------------|------------------|
| 1. Indicator light | 3. Middle button |
| 2. Right button | 4. Left button |

- Left Button, Menu Access/Back Button—press this button to access the InfoCenter menus. You can use it to exit any menu that you are currently using.













InfoCenter Icon Description

SERVICE DUE	Indicates when scheduled service should be performed
	Hours remaining until service
	Reset the service hours 
	The status of the engine speed (rpm)
	Info icon
	Maximum traction speed setting
	Fast
	Slow
	The fan is reversed.
	The air-intake heater is active.
	Raise the left cutting unit.
	Raise the center cutting unit.
	Raise the right cutting unit.
	The operator must sit in the seat.
	The parking brake is engaged.
H	The range is high.
N	Neutral
L	Identifies the range as Low
	Coolant temperature (°C or °F)
	Temperature (hot)
	Traction or Traction Pedal
	Not allowed
	Start the engine.
	The PTO is on.

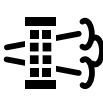
InfoCenter Icon Description (cont'd.)

	The cruise control is on.
	Shut off the engine
	Engine
	Key switch
	Cutting units are lowering
	Cutting units are raising
	PIN code
	Hydraulic fluid temperature
CAN	CAN bus
	InfoCenter
Bad	Bad or failed
Ctr	Center
Rht	Right
Left	Left
	Bulb
OUT	Output of TEC controller or control wire in harness
HI	Over the allowed range
LO	Under the allowed range
HI LO	Out of range
	Switch
	Operator must release switch
	Operator should change to indicated state
Symbols are often combined to form sentences. Some examples are shown below.	

InfoCenter Icon Description (cont'd.)

	Operator should put machine in neutral
	Engine start is denied
	Engine shutdown
	Engine coolant is too hot
	Hydraulic fluid is too hot
	DPF ash accumulation notification. Refer to Servicing the Diesel Particulate Filter (DPF) in the maintenance section for details
	Reset-standby regeneration request
	Parked or recovery regeneration request
	A parked or recovery regeneration is processing.
	High exhaust temperature
	NOx control diagnosis malfunction; drive the machine back to the shop and contact your authorized Toro distributor (software version U and later).
	The power take-off is disabled.
	Sit down or engage the parking brake.

 Accessible only by entering PIN

Using the Menu



To access the InfoCenter menu system, press the menu access button while at the main screen. This brings you to the main menu. Refer to the following tables for a synopsis of the options available from the menus:

Main Menu—Menu Item	Description
Faults	Contains a list of the recent machine faults. Refer to the <i>Service Manual</i> or your authorized Toro distributor for more information on the Faults menu and the information contained there.
Service	Contains information on the machine such as hours of use, counters, and other similar numbers
Diagnostics	Displays the state of each machine switch, sensor, and control output. You can use this to troubleshoot certain issues as it quickly tells you which machine controls are ON and which are OFF.
Settings	Allows you to customize and modify configuration variables on the InfoCenter display.
About	Lists the model number, serial number, and software version of your machine.

Service—Menu Item	Description
Hours	Lists the total number of hours that the machine, engine, and PTO have been on, as well as the number of hours the machine has been transported and service due
Counts	Lists numerous counts the machine has experienced.
DPF Regeneration	The diesel particulate filter regeneration option and DPF submenus
Inhibit Regen	Use to control reset regeneration
Parked Regen	Use to initiate a parked regeneration
Last Regen	Lists the number hours since the last reset, parked, or recovery regeneration
Recover Regen	Use to initiate a recovery regeneration

Diagnostics—Menu Item	Description
Cutting Units	Indicates the inputs, qualifiers, and outputs for raising and lowering the cutting units

Hi/Low Range	Indicates the inputs, qualifiers, and outputs for driving in transport mode
PTO	Indicates the inputs, qualifiers, and outputs for enabling the PTO circuit
Engine Run	Indicates the inputs, qualifiers, and outputs for starting the engine

Settings—Menu Item	Description
Units	Controls the units used on the InfoCenter (English or Metric)
Language	Controls the language used on the InfoCenter*
LCD Backlight	Controls the brightness of the LCD display
LCD Contrast	Controls the contrast of the LCD display
Protected Menus 	Allows a person authorized by your company with the PIN code to access protected menus
Protect Settings 	Allows the ability to change the settings in the protected settings
Counterbalance 	Controls the amount of counterbalance applied to the cutting decks

 Protected under Protected Menus—accessible only by entering PIN

About—Menu Item	Description
Model	Lists the model number of the machine
SN	Lists the serial number of the machine
Machine Controller Revision	Lists the software revision of the master controller
InfoCenter Revision	Lists the software revision of the InfoCenter
CAN Bus	Lists the machine communication bus status

Protected Menu

There are 2 operating configuration settings that are adjustable within the Settings Menu of the InfoCenter: auto idle time delay and counterbalance. To lock these settings, use the Protected Menu.

Note: At the time of delivery, the initial password code is programmed by your distributor.

Accessing Protected Menu

Note: The factory default PIN code for you machine is either 0000 or 1234.

If you changed the PIN code and forgot the code, contact your authorized Toro distributor for assistance.

1. From the MAIN MENU, use the center button to scroll down to the SETTINGS MENU and press the right button (Figure 16).

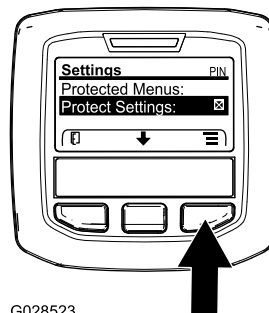

G028523

g028523

Figure 16

2. In the SETTINGS MENU, use the center button to scroll down to the PROTECTED MENU and press the right button (Figure 17A).

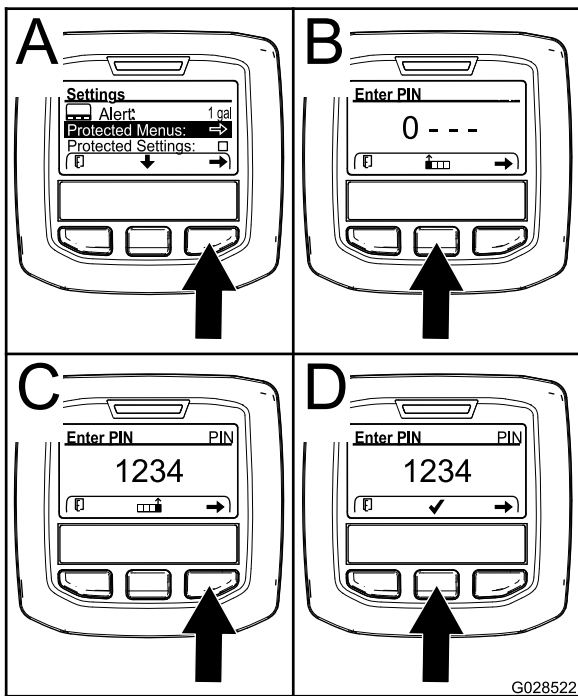

Figure 17

G028522

g028522

Viewing and Changing the Protected Menu Settings

1. In the Protected Menu, scroll down to Protect Settings.
2. To view and change the settings without entering a PIN code, use the right button to change the Protect Settings to OFF.
3. To view and change the settings with a PIN code, use the left button to change the Protect Settings to ON, set the PIN code, and turn the key in the ignition switch to the OFF position and then to the ON position.

Setting the Counterbalance

1. In the Settings Menu, scroll down to Counterbalance.
2. Press the right button to select counterbalance and change between the low, medium, and high settings.

Setting the Auto Idle

1. In the Settings Menu, scroll down to Auto Idle.
2. Press the right button to change the auto idle time between OFF, 8S, 10S, 15S, 20S, and 30S.

3. To enter the PIN code, press the center button until the correct first digit appears, then press the right button to move on to the next digit (Figure 17B and Figure 17C). Repeat this step until the last digit is entered and press the right button once more.
4. Press the middle button to enter the PIN code (Figure 17D).

Wait until the red indicator light of the InfoCenter illuminates.

Note: If the InfoCenter accepts the PIN code and the protected menu is unlocked, the word "PIN" displays in the upper right corner of the screen.

Note: Rotate the key switch to the OFF position and then to the ON position locks the protected menu.

You can view and change the settings in the Protected Menu. Once you access the Protected Menu, scroll down to Protect Settings option. Use the right button to change the setting. Setting the Protect Settings to OFF allows you to view and change the settings in the Protected Menu without entering the PIN code. Setting the Protect Settings to ON hides the protected options and requires you to enter the PIN code to change the setting in the Protected Menu. After you set the PIN code, rotate the key switch OFF and back to the ON position to enable and save this feature.

Specifications

Note: Specifications and design are subject to change without notice.

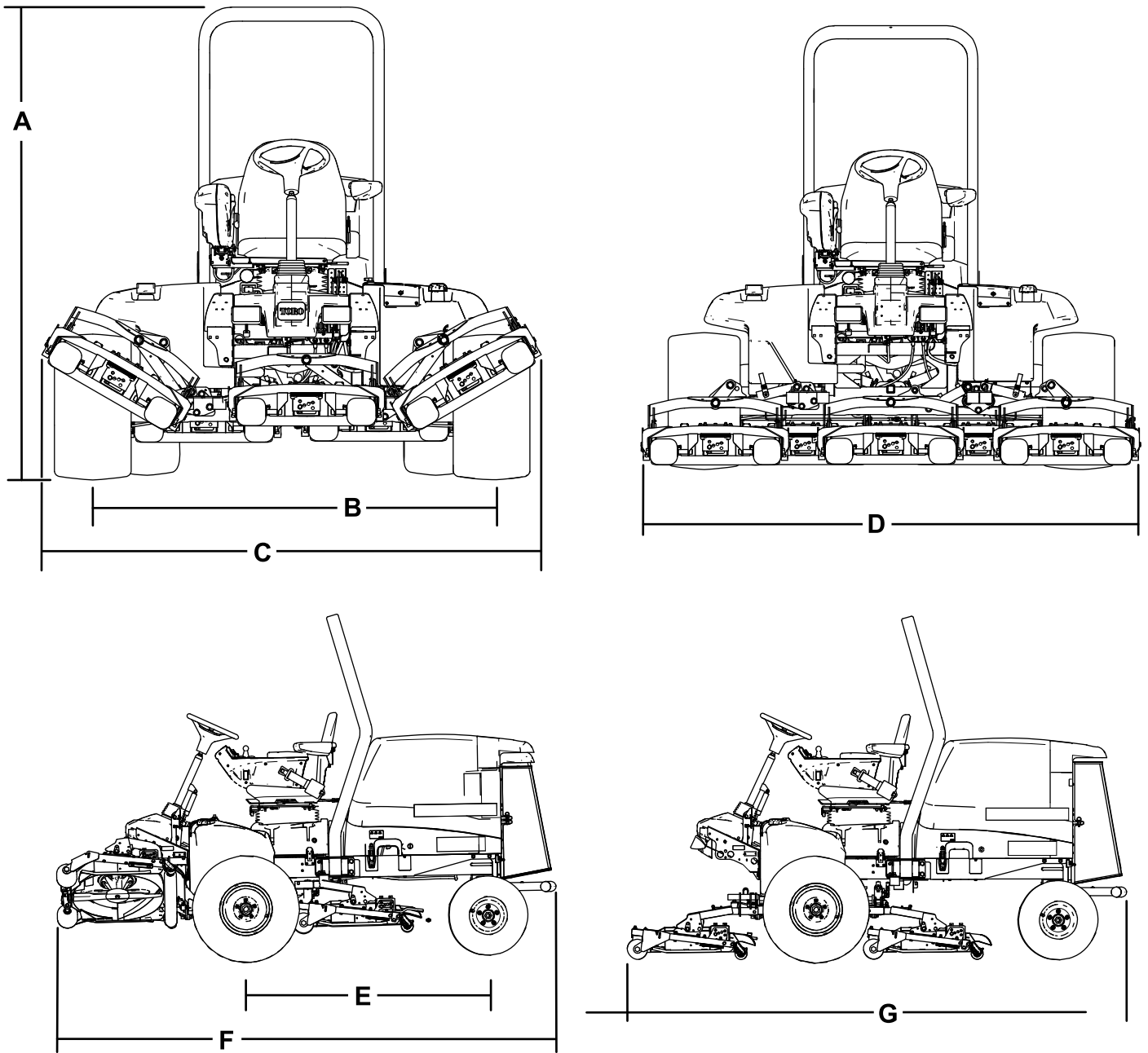

Figure 18

g193881

Description	Figure 18 reference	Dimension or Weight
Overall height	A	217 cm (85.5 inches)
Wheel tread (tire center to center) rear	B	185 cm (72.5 inches)
Overall width (transport position)	C	231 cm (91 inches)
Overall width (mowing position)	D	247 cm (97 inches)
Wheel base	E	152 cm (60 inches)
Overall length (transport position)	F	315 cm (124 inches)
Overall length (mowing position)	G	315 cm (124 inches)
Fuel-tank capacity		51 L (13.5 US gallons)
Transport speed		0 to 16 km/h (0 to 10 mph)
Mowing speed		0 to 13 km/h (0 to 8 mph)
Net weight (with cutting decks and fluids)		1492 kg (3,289 lb)

Cutting Unit Specifications

Length	86.4 cm (34 inches)
Width	86.4 cm (34 inches)
Height	24.4 cm (9.6 inches) to carrier mount 26.7 cm (10-1/2 inches) at 3/4 inch height of cut 34.9 cm (13-3/4 inches) at 4 inch height of cut
Weight	88 kg (195 lb)

Attachments/Accessories

A selection of Toro approved attachments and accessories is available for use with the machine to enhance and expand its capabilities. Contact your Authorized Service Dealer or authorized Toro distributor or go to www.Toro.com for a list of all approved attachments and accessories.

To ensure optimum performance and continued safety certification of the machine, use only genuine Toro replacement parts and accessories. Replacement parts and accessories made by other manufacturers could be dangerous, and such use could void the product warranty.

Operation

Note: Determine the left and right sides of the machine from the normal operating position.

Before Operation

Before Operation Safety

General Safety

- Never allow children or untrained people to operate or service the machine. Local regulations may restrict the age of the operator. The owner is responsible for training all operators and mechanics.
- Become familiar with the safe operation of the equipment, operator controls, and safety signs.
- Shut off the engine, remove the key, and wait for all movement to stop before you leave the operator's position. Allow the machine to cool before adjusting, servicing, cleaning, or storing it.
- Know how to stop the machine and shut off the engine quickly.
- Check that operator-presence controls, safety switches, and guards are attached and functioning properly. Do not operate the machine unless they are functioning properly.
- Before mowing, always inspect the machine to ensure that the blades, blade bolts, and cutting assemblies are in good working condition. Replace worn or damaged blades and bolts in sets to preserve balance.
- Inspect the area where you will use the machine and remove all objects that the machine could throw.

Fuel Safety

- Use extreme care in handling fuel. It is flammable and its vapors are explosive.
- Extinguish all cigarettes, cigars, pipes, and other sources of ignition.
- Use only an approved fuel container.
- Do not remove the fuel cap or fill the fuel tank while the engine is running or hot.
- Do not add or drain fuel in an enclosed space.
- Do not store the machine or fuel container where there is an open flame, spark, or pilot light, such as on a water heater or other appliance.
- If you spill fuel, do not attempt to start the engine; avoid creating any source of ignition until the fuel vapors have dissipated.

Filling the Fuel Tank

Fuel Tank Capacity

53 L (14 US gallons)

Fuel Specification

Important: Use only ultra-low sulphur diesel fuel. Fuel with higher rates of sulfur degrades the diesel oxidation catalyst (DOC), which causes operational problems and shortens the service life of engine components.

Failure to observe the following cautions may damage the engine.

- Never use kerosene or gasoline instead of diesel fuel.
- Never mix kerosene or used engine oil with the diesel fuel.
- Never keep fuel in containers with zinc plating on the inside.
- Do not use fuel additives.

Petroleum Diesel

Cetane rating: 45 or higher

Sulfur content: Ultra-low sulfur (<15 ppm)

Fuel Table

Diesel fuel specification	Location
ASTM D975 No. 1-D S15 No. 2-D S15	USA
EN 590	European Union
ISO 8217 DMX	International
JIS K2204 Grade No. 2	Japan
KSM-2610	Korea

- Use only clean, fresh diesel fuel or biodiesel fuels.
- Purchase fuel in quantities that can be used within 180 days to ensure fuel freshness.

Use summer-grade diesel fuel (No. 2-D) at temperatures above -7°C (20°F) and winter-grade fuel (No. 1-D or No. 1-D/2-D blend) below that temperature.

Note: Use of winter-grade fuel at lower temperatures provides lower flash point and cold flow characteristics which eases starting and reduces fuel filter plugging.

Using summer-grade fuel above -7°C (20°F) contributes toward longer fuel pump life and increased power compared to winter-grade fuel.

Biodiesel

This machine can also use a biodiesel blended fuel of up to B20 (20% biodiesel, 80% petroleum diesel).

Sulfur content: Ultra-low sulfur (<15 ppm)

Biodiesel fuel specification: ASTM D6751 or EN14214

Blended fuel specification: ASTM D975, EN590, or JIS K2204

Important: The petroleum diesel portion must be ultra-low sulfur.

Observe the following precautions:

- Biodiesel blends may damage painted surfaces.
- Use B5 (biodiesel content of 5%) or lesser blends in cold weather.
- Monitor seals, hoses, gaskets in contact with fuel as they may be degraded over time.
- Fuel filter plugging may be expected for a time after converting to biodiesel blends.
- Contact your authorized Toro distributor for more information on biodiesel.

Adding Fuel

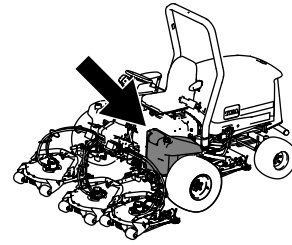

g194207

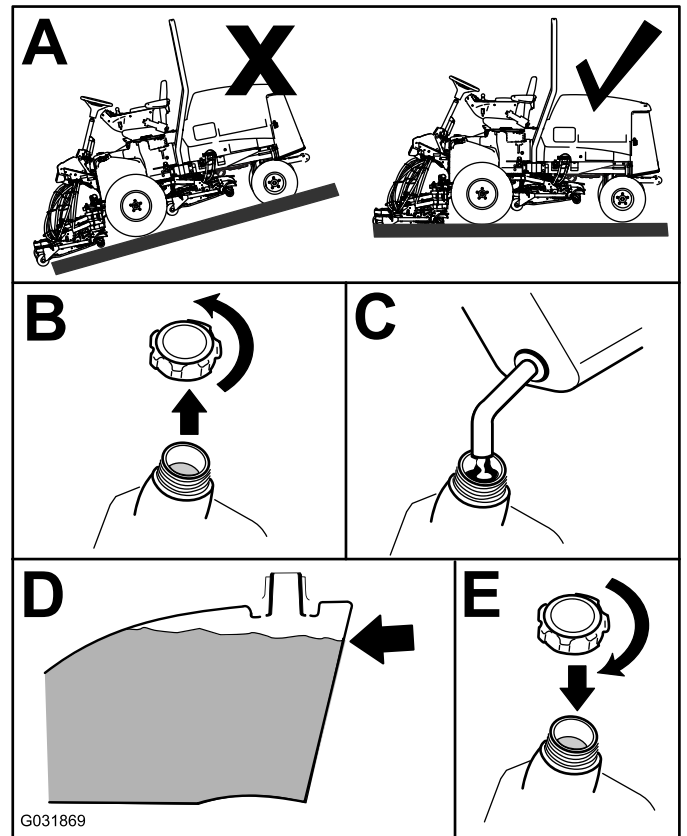

G031869

g031869

Figure 19

Fill the tank to about 6 to 13 mm ($1/4$ to $1/2$ inch) below the top of the tank, not the filler neck, with Number 2-D diesel fuel.

Note: If possible, fill the fuel tank after each use; this will minimize possible buildup of condensation inside the fuel tank.

Checking the Engine-Oil Level

Before you start the engine and use the machine, check the oil level in the engine crankcase; refer to [Checking the Engine-Oil Level \(page 54\)](#).

Checking the Cooling System

Before you start the engine and use the machine, check the cooling system; refer to [Checking the Cooling System \(page 26\)](#).

Checking the Hydraulic System

Before you start the engine and use the machine, check the hydraulic system; refer to [Checking the Hydraulic-Fluid Level \(page 64\)](#).

Draining the Water Separator

Drain water or other contaminants from the water separator; refer to [Servicing the Water Separator \(page 56\)](#).

Checking the Tire Pressure

Service Interval: Before each use or daily

The correct air pressure in the front and rear tires is 83 to 103 kPa (12 to 15 psi).

Important: Maintain pressure in all tires to ensure a good quality of cut and proper machine performance. *Do not under-inflate the tires.*

Check the air pressure in all the tires before operating the machine.

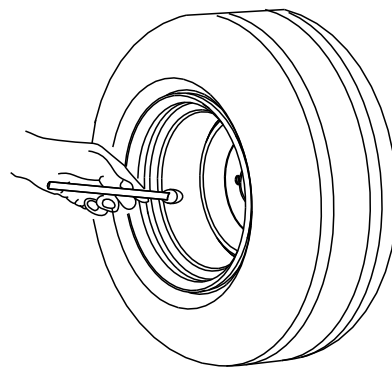

G001055

g001055

Figure 20

Checking the Torque of the Wheel-Lug Nuts

Service Interval: After the first hour

After the first 10 hours

Every 250 hours

⚠ WARNING

Failure to maintain the proper torque of the wheel nuts could result in failure or loss of a wheel, and may result in personal injury.

Torque the front and rear-wheel nuts to 94 to 122 N·m (70 to 90 ft-lb) at the recommended service intervals.

Adjusting the Height of Cut

Important: The cutting units often cut approximately 6 mm (1/4 inch) lower than a reel cutting unit with the same bench setting. It may be necessary to set the cutting-unit bench measurement at 6 mm (1/4 inch) above that of reel cutting units cutting in the same area.

Important: Access to the rear cutting units is greatly improved by removing the cutting unit from the machine.

1. Park the machine on a level surface, engage the parking brake, lower the cutting unit to the ground, shut off the engine, and remove the key.
2. Loosen the bolt securing each height-of-cut bracket to the height-of-cut plate (front and each side) as shown in Figure 21.
3. Beginning with front adjustment, remove the bolt.

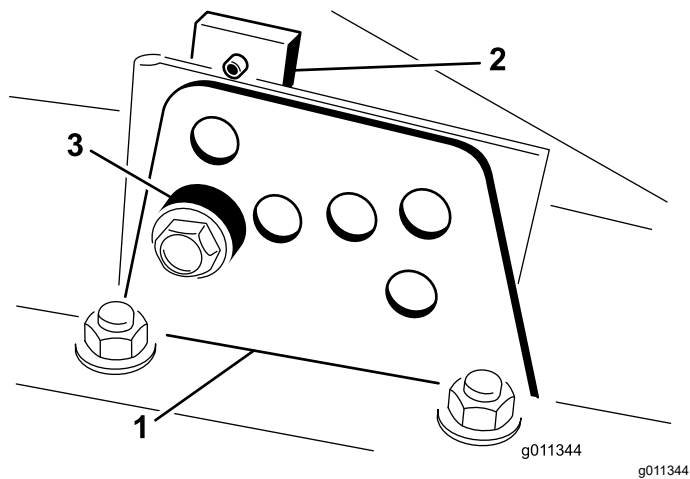

Figure 21

1. Height-of-cut bracket
2. Height-of-cut plate
3. Spacer

4. While supporting the chamber, remove the spacer (Figure 21).
5. Move the chamber to the desired height of cut and install a spacer into the designated height-of-cut hole and slot (Figure 22).

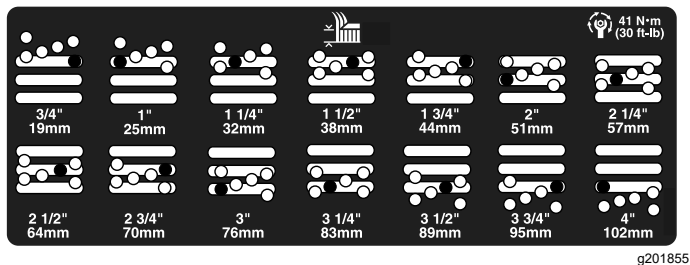

Figure 22

6. Position the tapped plate in-line with the spacer.
7. Install the bolt finger-tight.
8. Repeat steps 4 through 7 for each side adjustment.
9. Torque all 3 bolts to 41 N·m (30 ft-lb). Always tighten the front bolt first.

Note: Adjustments of more than 3.8 cm (1-1/2 inches) may require temporary assembly to an intermediate height to prevent binding (e.g., changing from 3.1 to 7 cm (1-1/4 to 2-3/4 inches) height of cut).

Checking the Safety-Interlock Switches

Service Interval: Before each use or daily

⚠ CAUTION

If the safety-interlock switches are disconnected or damaged, the machine could operate unexpectedly and cause personal injury.

- Do not tamper with the safety-interlock switches.
- Check the operation of the safety-interlock switches daily and replace any damaged switches before operating the machine.

The machine has interlock switches in the electrical system. These switches disengage either the traction or the PTO whenever you leave the seat. Although the engine continues to run if you disengage the PTO switch, and you release the traction pedal, shut off the engine before rising from the seat.

1. Park the machine on a level surface, lower the cutting unit, shut off the engine, and engage the parking brake.
2. Press the traction pedal. Turn the key in the ignition switch to the ON position.

Note: If the engine cranks, there is a malfunction in the interlock system. Correct this malfunction before operating the machine.

3. Turn the key in the ignition switch to the ON position, start the engine, rise from the seat, and move the PTO switch to the ON position.

Note: The PTO should not engage. If the PTO engages, there is a malfunction in the interlock system. Correct this malfunction before operating the machine.

4. Engage the parking brake, turn the key in the ignition switch to the ON position, start the engine, and move the traction pedal out of the NEUTRAL position.

Note: The InfoCenter displays "traction denied" and the machine should not move. If the machine does move, there is a malfunction in the interlock system. Correct this malfunction before operating the machine.

5. Start the engine with the PTO engaged.

Note: If the engine cranks, there is a malfunction in the interlock system. Correct this malfunction before operating the machine.

Checking the Blade Stopping Time

Service Interval: Before each use or daily

The blades of the cutting deck should come to a complete stop in approximately 5 seconds after you shut down the cutting-deck-engagement switch.

Note: Make sure that the decks are lowered onto a clean section of turf or hard surface to avoid thrown dust and debris.

1. Have a second person stand back from the deck at least 6 m (20 feet) and watch the blades on 1 of the cutting decks.
2. Shut the cutting decks down and record the time it takes for the blades to come to a complete stop.

Note: If this time is greater than 7 seconds, the braking valve needs adjustment. Call your authorized Toro distributor for assistance in making this adjustment.

Burnishing the Brakes

To ensure optimum performance of the parking-brake system, burnish (break in) the brakes before use. Set the forward traction speed to 6.4 km/h (4 mph) to match the reverse traction speed (all 8 spacers moved to the top of the mow-speed control). With the engine at high idle, proceed forward with the mow-speed-control stop engaged and ride the brake for 15 seconds. Proceed backward at full reverse speed and ride the brake for 15 seconds. Repeat this 5 times, waiting 1 minute between each forward and reverse cycle to avoid overheating the brakes; refer to [Adjusting the Parking Brakes \(page 62\)](#).

Selecting a Blade

Standard Combination Sail

This blade was designed to provide excellent lift and dispersion in almost any condition. If more or less lift and discharge velocity is required, consider a different blade.

Attributes: Excellent lift and dispersion in most conditions

Angled Sail (Not CE Compliant)

The blade generally performs best in lower heights of cut—1.9 to 6.4 cm (3/4 to 2-1/2 inches).

Attributes:

- Discharge remains more even at lower heights of cut.
- Discharge has less tendency to throw left and thus a cleaner look around bunkers and fairways.
- Lower power requirement at lower heights and dense turf.

High-Lift Parallel Sail (Not CE Compliant)

The blade generally performs better in the higher heights of cut—7 to 10 cm (2 to 4 inches).

Attributes:

- More lift and higher discharge velocity
- Sparse or limp turf is picked up significantly at higher heights of cut
- Wet or sticky clippings are discharged more efficiently reducing congestion in the deck
- Requires more horsepower to run
- Tends to discharge further left and can tend to windrow at lower heights of cut

▲ WARNING

Using a high-lift blade with the mulching baffle could cause the blade to break, resulting in personal injury or death.

Do not use the high-lift blade with the mulching baffle.

Atomic Blade

This blade was designed to provide excellent leaf mulching.

Attribute: Excellent leaf mulching

Understanding the Diagnostic Light

The machine is equipped with a diagnostic light, which indicates if the machine detects a malfunction. The diagnostic light is located on the InfoCenter, above the display screen (Figure 23). When the machine functions properly and the key switch is moved to the ON/RUN position, the diagnostic light turns on briefly to indicate that the light is working properly. When a machine advisory message displays, the light illuminates when the message is present. When a fault message is displayed, the light blinks until the fault is resolved.

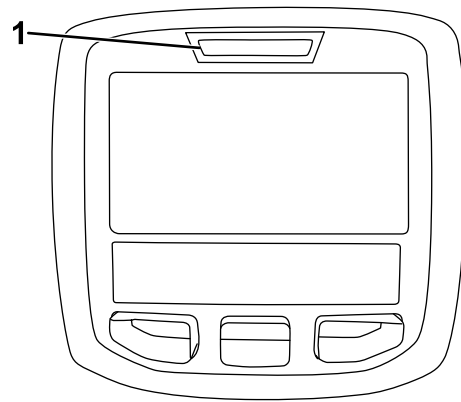

g021272

g021272

Figure 23

1. Diagnostic light

Changing the Counterbalance Settings

You can change the amount of required cutting-unit counterbalance (upward lift) to meet your current mowing conditions.

1. Park the machine on a level surface, lower the cutting decks, turn the key in the switch to the OFF position, and engage the parking brake.
2. Turn the key in the switch to the RUN position.
3. In the InfoCenter Settings Menu, scroll down to **Counterbalance**.
4. Press the right button to select counterbalance and change between the low, medium, and high settings.

Note: Once the adjustment has been completed, move the machine to a test area and operate the machine with the new setting. The new counterbalanced setting may change the effective height of cut.

Choosing Accessories

Optional Equipment Configurations

	Angle Sail Blade	High-Lift, Parallel-Sail Blade (<i>Do not use with the mulching baffle</i>) (Not CE Compliant)	Mulching Baffle	Roller Scraper
Grass Cutting: 1.9 to 4.4 cm (3/4 to 1-3/4 inches) height of cut	Recommended in most applications	May work well in light or sparse turf	Has been shown to improve dispersion and after-cut performance on northern grasses that are cut at least 3 times per week and less than 1/3 of the grass blade is removed. Do not use with the high-lift, parallel-sail blade	Use it whenever the rollers build up with grass or large, flat grass clumps of grass are seen. The scrapers may increase clumping in certain applications.
Grass Cutting: 5 to 6.4 cm (2 to 2-1/2 inches) height of cut	Recommended for thick or lush turf	Recommended for light or sparse turf		
Grass Cutting: 7 to 10 cm (2-3/4 to 4 inches) height of cut	May work well in lush turf	Recommended in most applications		
Leaf Mulching	Recommended for use with the mulching baffle	Not Allowed	Use with combination sail or angle sail blade only	
Pros	Even discharge at lower height of cut; cleaner look around bunkers and fairways; lower power requirements	More lift and higher discharge velocity; sparse or limp turf is picked up at high height of cut; wet or sticky clippings are discharged efficiently	May improve dispersion and appearance in certain grass cutting applications; very good for leaf mulching	Reduces roller buildup in certain applications
Cons	Does not lift the grass well in high height-of-cut applications; wet or sticky grass has a tendency to build up in the chamber, leading to poor quality of cut and higher power requirements	Requires more power to run in some applications; tends to windrow at lower height of cut in lush grass; do not use with the mulching baffle	Grass will build up in the chamber if you attempt to remove too much grass with the baffle in place	

During Operation

During Operation Safety

General Safety

- The owner/operator can prevent and is responsible for accidents that may cause personal injury or property damage.
- Wear appropriate clothing, including eye protection; long pants; substantial, slip-resistant footwear; and hearing protection. Tie back long hair and do not wear loose clothing or loose jewelry.
- Do not operate the machine while ill, tired, or under the influence of alcohol or drugs.
- Use your full attention while operating the machine. Do not engage in any activity that causes distractions; otherwise, injury or property damage may occur.
- Before you start the engine, ensure that all drives are in neutral, the parking brake is engaged, and you are in the operating position.
- Do not carry passengers on the machine and keep bystanders and children out of the operating area.
- Operate the machine only in good visibility to avoid holes or hidden hazards.
- Avoid mowing on wet grass. Reduced traction could cause the machine to slide.
- Keep your hands and feet away from rotating parts. Keep clear of the discharge opening.
- Look behind and down before backing up to be sure of a clear path.
- Use care when approaching blind corners, shrubs, trees, or other objects that may obscure your vision.
- Stop the blades whenever you are not mowing.
- Stop the machine, remove the key, and wait for all moving parts to stop before inspecting the attachment after striking an object or if there is an abnormal vibration in the machine. Make all necessary repairs before resuming operation.
- Slow down and use caution when making turns and crossing roads and sidewalks with the machine. Always yield the right-of-way.
- Disengage the drive to the cutting unit, shut off the engine, remove the key, and wait for all movement to stop before adjusting the height of cut (unless you can adjust it from the operating position).
- Operate the engine only in well-ventilated areas. Exhaust gases contain carbon monoxide, which is lethal if inhaled.
- Never leave a running machine unattended.

- Before you leave the operator's position, do the following:
 - Park the machine on a level surface.
 - Disengage the power takeoff and lower the attachments.
 - Engage the parking brake.
 - Shut off the engine and remove the key.
 - Wait for all movement to stop.
- Operate the machine only in good visibility. Do not operate the machine when there is the risk of lightning.
- Do not use the machine as a towing vehicle.
- Use accessories, attachments, and replacement parts approved by Toro only.

Rollover Protection System (ROPS) Safety

- The ROPS is an integral and effective safety device.
- Do not remove any of the ROPS components from the machine.
- Ensure that the seat belt is attached to the machine.
- Pull the belt strap over your lap and connect the belt to the buckle on the other side of the seat.
- To disconnect the seat belt, hold the belt, press the buckle button to release the belt, and guide the belt into the auto-retract opening. Ensure that you can release the belt quickly in an emergency.
- Check carefully for overhead obstructions and do not contact them.
- Keep the ROPS in safe operating condition by thoroughly inspecting it periodically for damage and keeping all the mounting fasteners tight.
- Replace damaged ROPS components. Do not repair or alter them.

Additional ROPS Safety for Machines with a Cab or a Fixed Roll Bar

- A cab installed by Toro is a roll bar.
- Always wear your seat belt.

Slope Safety

- Slopes are a major factor related to loss of control and rollover accidents, which can result in severe injury or death. You are responsible for safe slope operation. Operating the machine on any slope requires extra caution.
- Evaluate the site conditions to determine if the slope is safe for machine operation, including

surveying the site. Always use common sense and good judgment when performing this survey.

- Review the slope instructions listed below for operating the machine on slopes and to determine whether you can operate the machine in the conditions on that day and at that site. Changes in the terrain can result in a change in slope operation for the machine.
- Avoid starting, stopping, or turning the machine on slopes. Avoid making sudden changes in speed or direction. Make turns slowly and gradually.
- Do not operate a machine under any conditions where traction, steering, or stability is in question.
- Remove or mark obstructions such as ditches, holes, ruts, bumps, rocks, or other hidden hazards. Tall grass can hide obstructions. Uneven terrain could overturn the machine.
- Be aware that operating the machine on wet grass, across slopes, or downhill may cause the machine to lose traction. Loss of traction to the drive wheels may result in sliding and a loss of braking and steering.
- Use extreme caution when operating the machine near drop-offs, ditches, embankments, water hazards, or other hazards. The machine could suddenly roll over if a wheel goes over the edge or the edge caves in. Establish a safety area between the machine and any hazard.
- Identify hazards at the base of the slope. If there are hazards, mow the slope with a pedestrian-controlled machine.
- If possible, keep the cutting unit(s) lowered to the ground while operating on slopes. Raising the cutting unit(s) while operating on slopes can cause the machine to become unstable.
- Use extreme caution with grass-collection systems or other attachments. These can change the stability of the machine and cause a loss of control.

Starting the Engine

Important: The fuel system automatically bleeds itself before starting the engine if you are starting the engine for the first time, the engine has shut off due to lack of fuel, or you have performed maintenance on the fuel system.

1. Sit on the seat, keep your foot off the traction pedal so that it is in NEUTRAL, engage the parking brake, set the engine-speed switch to the MID position, and ensure that the Enable/Disable switch is in the DISABLE position.
2. Turn the key in the switch to the RUN position.
3. When the glow indicator dims, turn the key in the switch to the START position. Release the key immediately when the engine starts and allow it to return to the RUN position.
4. Run the engine at low idle speed until it warms up.

Shutting Off the Engine

1. Move all controls to NEUTRAL, engage the parking brake, move the engine-speed switch to the LOW IDLE position and allow the engine to reach low idle speed.

Important: Allow the engine to idle for 5 minutes before shutting it off after a full load operation. Failure to do so may lead to trouble on a turbo-charged engine.

2. Turn the key in the switch to the OFF position and remove the key.

Cutting Grass with the Machine

Note: Cutting grass at a rate that loads the engine promotes DPF regeneration.

1. Move the machine to the job site.
2. Whenever possible, set the engine-speed switch to high idle.
3. Engage the PTO switch.
4. Gradually move the traction pedal forward and slowly drive the machine over the mowing area.
5. Once the front of the cutting units are over the mowing area, lower the cutting units.
6. Cut grass so that the blades can cut and discharge clippings at a high rate while producing a good quality of cut.

Note: If the cutting rate is too high, the quality of cut may deteriorate. Reduce the ground speed of the machine or reduce the width of cut to regain high idle engine speed.

7. When the cutting units are over the far edge of the mowing area, lift the cutting units.
8. Perform a tear-shaped turn to quickly line up for your next pass.

- If the back pressure in the DPF is too high or a reset regeneration has not occurred for 100 hours, the engine computer signals you through the InfoCenter when reset regeneration is running.
- Allow the reset regeneration process to complete before shutting off the engine.

Diesel Particulate Filter Regeneration

The diesel particulate filter (DPF) is part of the exhaust system. The diesel-oxidation catalyst of the DPF reduces harmful gasses and the soot filter removes soot from the engine exhaust.

The DPF regeneration process uses heat from the engine exhaust to incinerate the soot accumulated on the soot filter, converting the soot to ash, and clears the channels of the soot filter so that filtered engine exhaust flows out the DPF.

The engine computer monitors the accumulation of soot by measuring the back pressure in the DPF. If the back pressure is too high, soot is not incinerating in the soot filter through normal engine operation. To keep the DPF clear of soot, remember the following:

- Passive regeneration occurs continuously while the engine is running—run the engine at full engine speed when possible to promote DPF regeneration.

Operate and maintain your machine with the function of the DPF in mind. Engine load at high idle (full throttle) engine speed generally produces adequate exhaust temperature for DPF regeneration.

Important: Minimize the amount of time that you idle the engine or operate the engine at low-engine speed to help reduce the accumulation of soot in the soot filter.

DPF Soot Accumulation

- Over time, the diesel particulate filter accumulates soot in the soot filter. The computer for the engine monitors the soot level in the DPF.
- When enough soot accumulates, the computer informs you that it is time to regenerate the DPF.
- DPF regeneration is a process that heats the DPF to convert the soot to ash.
- In addition to the warning messages, the computer reduces the power produced by the engine at different soot-accumulation levels.

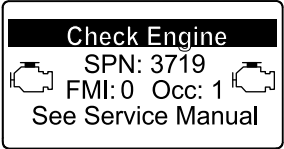

Engine Warning Messages—Soot Accumulation

Indication Level	Fault Code	Engine Power Rating	Recommended Action
Level 1: Engine Warning	 <p style="text-align: center;"><small>g213866</small> Figure 24 Check Engine SPN 3719, FMI 16</p>	The computer de-rates the engine power to 85%.	Perform a parked regeneration as soon as possible; refer to Parked or Recovery Regeneration (page 40) .
Level 2: Engine Warning	 <p style="text-align: center;"><small>g213867</small> Figure 25 Check Engine SPN 3719, FMI 0</p>	The computer de-rates the engine power to 50%.	Perform a recovery regeneration as soon as possible; refer to Parked or Recovery Regeneration (page 40) .

DPF Ash Accumulation

- The lighter ash is discharged through the exhaust system; the heavier ash collects in the soot filter.
- Ash is a residue of the regeneration process. Over time, the diesel particulate filter accumulates ash that does not discharge with the engine exhaust.
- The computer for the engine calculates the amount of ash accumulated in the DPF.
- When enough ash accumulates, the engine computer sends information to the InfoCenter in the form of an engine fault to indicate the accumulation of ash in the DPF.
- The fault messages indicate that it is time to service the DPF.
- In addition to the warnings, the computer reduces the power produced by the engine at different ash-accumulation levels.

InfoCenter Advisory and Engine Warning Messages—Ash Accumulation



Indication Level	Fault Code	Engine Speed Reduction	Engine Power Rating	Recommended Action
Level 1: Engine Warning	 <p>g213863</p> <p>Figure 26 Check Engine SPN 3720, FMI 16</p>	None	The computer de-rates the engine power to 85%.	Service the DPF; refer to Servicing the Diesel-Oxidation Catalyst (DOC) and the Soot Filter (page 57)
Level 2: Engine Warning	 <p>g213863</p> <p>Figure 27 Check Engine SPN 3720, FMI 16</p>	None	The computer de-rates the engine power to 50%.	Service the DPF; refer to Servicing the Diesel-Oxidation Catalyst (DOC) and the Soot Filter (page 57)

Types of Diesel Particulate Filter Regeneration

Types of diesel particulate filter regeneration that are performed while the machine is operating:

Type of Regeneration	Conditions that cause DPF regeneration	DPF description of operation
Passive	Occurs during normal operation of the machine at high-engine speed or high-engine load	<ul style="list-style-type: none"> The InfoCenter does not display an icon indicating passive regeneration. During passive regeneration, the DPF processes high-heat exhaust gasses, oxidizing harmful emissions, and burning soot to ash. Refer to Passive DPF Regeneration (page 37) .
Assist	Occurs because of low-engine speed, low-engine load, or after the computer detects the DPF is becoming obstructed with soot	<ul style="list-style-type: none"> The InfoCenter does not display an icon indicating assist regeneration. During assist regeneration, the engine computer adjusts the engine settings to raise the exhaust temperature. Refer to Assist DPF Regeneration (page 38) .
Reset	Occurs every 100 hours Also occurs after assist regeneration only if the computer detects that assist regeneration did not sufficiently reduce the soot level	 <ul style="list-style-type: none"> When the high exhaust-temperature icon is displayed in the InfoCenter, a regeneration is in progress. During reset regeneration, the engine computer adjusts the engine settings to raise the exhaust temperature. Refer to Reset Regeneration (page 38) .

Types of diesel particulate filter regeneration that require you to park the machine:

Type of Regeneration	Conditions that cause DPF regeneration	DPF description of operation
Parked	Occurs because the computer detects back pressure in the DPF due to soot buildup Also occurs because the operator initiates a parked regeneration May occur because you set the InfoCenter to inhibit reset regeneration and continued operating the machine, adding more soot when the DPF already needs a reset regeneration May result from using the incorrect fuel or engine oil	 <ul style="list-style-type: none"> When the reset-standby/parked or recovery regeneration icon  or ADVISORY #188 displays in the InfoCenter, a regeneration is requested. Perform the parked regeneration as soon as possible to avoid needing a recovery regeneration. A parked regeneration requires 30 to 60 minutes to complete. You must have at least a 1/4 tank of fuel in the tank. You must park the machine to perform a parked regeneration. Refer to Parked or Recovery Regeneration (page 40) .

Types of diesel particulate filter regeneration that require you to park the machine: (cont'd.)

Type of Regeneration	Conditions that cause DPF regeneration	DPF description of operation
Recovery	Occurs because the operator ignored requests for a parked regeneration and continued operating the machine, adding more soot to the DPF	<ul style="list-style-type: none"> When the reset-standby/parked or recovery regeneration icon  or ADVISORY #190 displays in the InfoCenter, a recovery regeneration is requested. A recovery regeneration requires up to 3 hours to complete. You must have at least a 1/2 tank of fuel in the machine. You must park the machine to perform a recovery regeneration. <p>Refer to Parked or Recovery Regeneration (page 40).</p>

Accessing the DPF Regeneration Menus

Accessing the DPF Regeneration Menus

1. Access the Service menu, press the center button to scroll down to the DPF REGENERATION option ([Figure 28](#)).

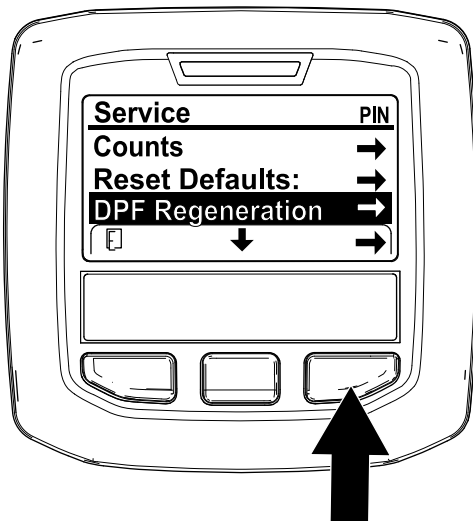

Figure 28

g227667

2. Press the right button to select the DPF Regeneration entry ([Figure 28](#)).

Time Since Last Regeneration

Access the DPF Regeneration menu, press the center button to scroll down to the LAST REGEN field ([Figure 29](#)).

Use the LAST REGEN field to determine how many hours you have run the engine since the last reset, parked, or recovery regeneration.

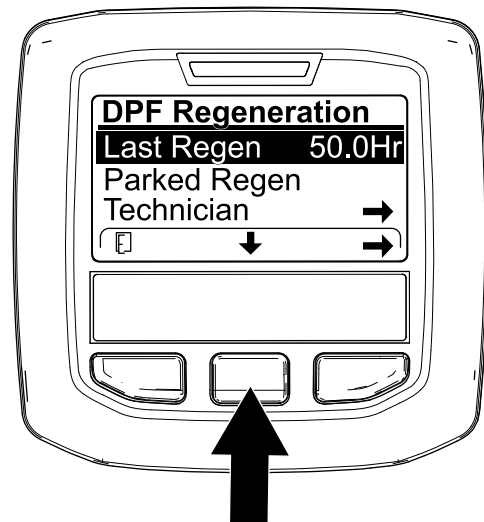

Figure 29

g224693

Technician Menu

Important: For operating convenience, you may decide to perform a parked regeneration before the soot load reaches 100%, provided the engine has run more than 50 hours since the last successful reset, parked, or recovery regeneration.

Use the technician menu to view the current state of engine regeneration control and view the reported soot level.

Access the DPF Regeneration menu, press the center button to scroll down to the TECHNICIAN option, and

press the right button to select the Technician entry (Figure 30).

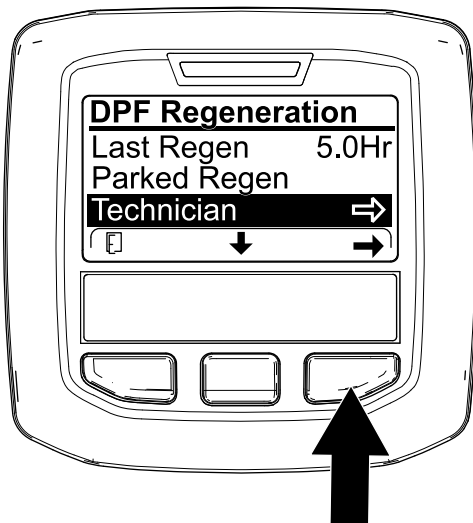

Figure 30

g227348

- Use the DPF operation table to understand the current state of DPF operation (Figure 31).

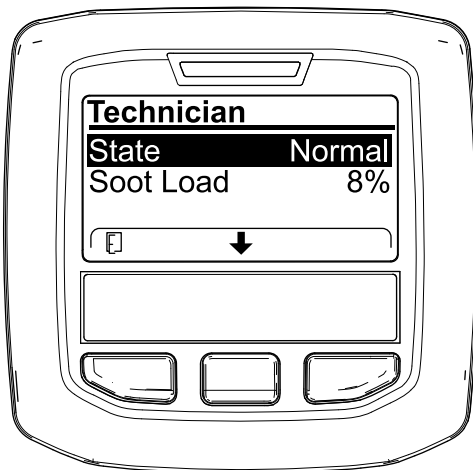

Figure 31

g227360

DPF Operation Table

State	Description	
Normal	The DPF is in normal-operating mode—passive regeneration.	
Assist Regen	The engine computer is performing an assist regeneration.	
Reset Stby	The engine computer is trying to run a reset regeneration, but 1 of the following conditions prevents regeneration:	The regen inhibit setting is set to ON.
		The exhaust temperature is too low for regeneration.

DPF Operation Table (cont'd.)

State	Description
Reset Regen	The engine computer is running a reset regeneration.
Parked Stby	The engine computer is requesting that you run a parked regeneration.
Parked Regen	You initiated a parked regeneration request and the engine computer is processing the regeneration.
Recov. Stby	The engine computer is requesting that you run a recovery regeneration.
Recov. Regen	You initiated a recovery regeneration request and the engine computer is processing the regeneration.

- View the soot load which is measured as the percentage of soot in the DPF (Figure 32); refer to the soot-load table.

Note: The soot load value varies as the machine is operated and DPF regeneration occurs.

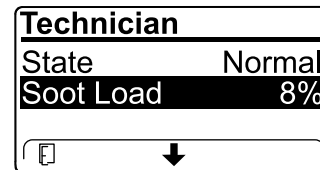

Figure 32

g227359

Soot-Load Table

Important Soot Load Values	Regeneration State
0% to 5%	Minimum soot load range
78%	The engine computer performs an assist regeneration.
100%	The engine computer automatically requests a parked regeneration.
122%	The engine computer automatically requests a recovery regeneration.

Passive DPF Regeneration

- Passive regeneration occurs as part of normal engine operation.
- While operating the machine, run the engine at full-engine speed and high load when possible to promote DPF regeneration.

Assist DPF Regeneration

- The engine computer adjusts engine settings to raise the exhaust temperature.
- While operating the machine, run the engine at full engine speed and high load when possible to promote DPF regeneration.

Reset Regeneration

⚠ CAUTION

The exhaust temperature is hot (approximately 600°C (1,112°F)) during DPF regeneration. Hot exhaust gas can harm you or other people.

- Never operate the engine in an enclosed area.
- Make sure that there are no flammable materials around the exhaust system.
- Never touch a hot exhaust system component.
- Never stand near or around the exhaust pipe of the machine.

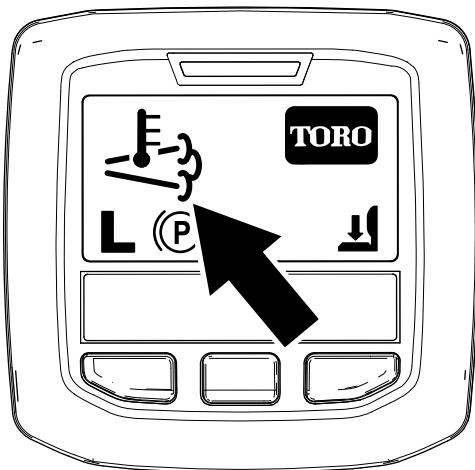



Figure 33

g224417

- The high exhaust-temperature icon  displays in the InfoCenter (Figure 33).
- The engine computer adjusts engine settings to raise the exhaust temperature.

Important: The high exhaust-temperature icon indicates that the exhaust temperature discharged from of your machine may be hotter than during regular operation.

- While operating the machine, run the engine at full engine speed and high load when possible to promote DPF regeneration.

- The icon displays in the InfoCenter while the reset regeneration is processing.
- Whenever possible, do not shut off the engine or reduce engine speed while the reset regeneration is processing.

Important: Whenever possible, allow the machine to complete the reset regeneration process before shutting off the engine.

Periodic Reset Regeneration

If the engine has not completed a successful Reset, Parked, or Recovery regeneration in the previous 100 hours of engine operation, the engine computer will attempt to perform a reset regeneration.

Setting the Inhibit Regen

Reset Regeneration Only

Note: If you set the InfoCenter to inhibit regeneration, the InfoCenter displays ADVISORY #185 (Figure 34) every 15 minutes while the engine requests a reset regeneration.

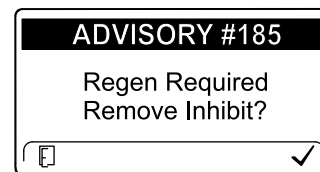

Figure 34

g224692

A reset regeneration produces the elevated engine exhaust. If you are operating the machine around trees, brush, tall grass, or other temperature-sensitive plants or materials, you can use the Inhibit Regen setting to prevent the engine computer from performing a reset regeneration.

Important: When you shut off the engine and start it again, the inhibit regen setting defaults to OFF.

1. Access the DPF Regeneration menu, press the center button to scroll down to the INHIBIT REGEN option, and press the right button to select the Inhibit Regen entry (Figure 35).

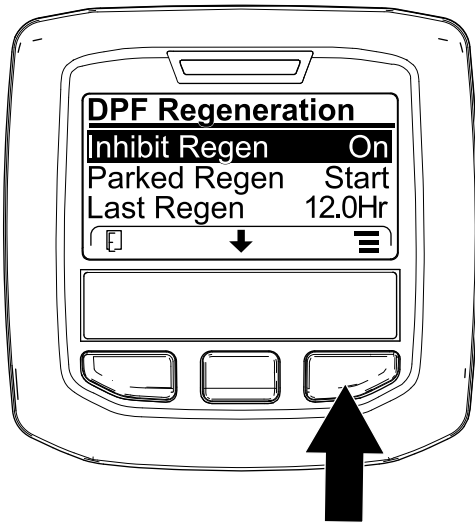

Figure 35

g227304

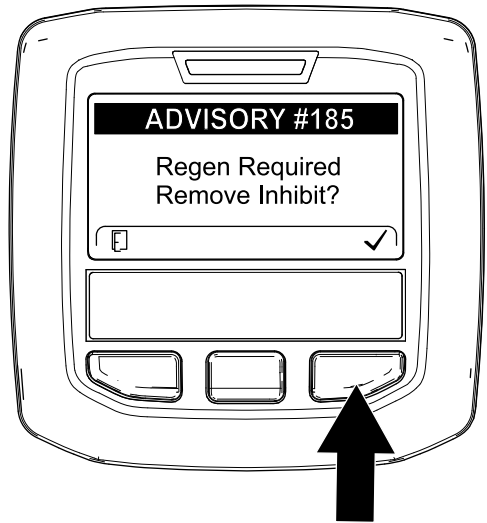

Figure 37

g224394

- Press the right button to change the inhibit regeneration setting from On to Off (Figure 35) or from Off to On (Figure 36).

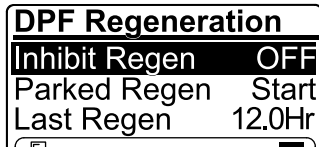

Figure 36

g224691

Note: If the InfoCenter displays ADVISORY #186 (Figure 38), set the engine to full throttle (high idle) to allow the reset regeneration to continue.

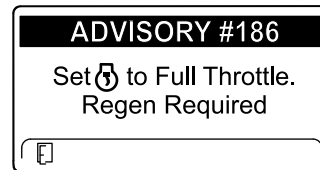



Figure 38

g224395

Allowing a Reset Regeneration

The InfoCenter displays the high exhaust-temperature

icon  when the reset regeneration is in process.

Note: If INHIBIT REGEN is set to ON, the InfoCenter displays ADVISORY #185 (Figure 37). Press button 3 to set inhibit regeneration setting to OFF and continue with the reset regeneration.

Note: When the reset regeneration completes, the

high exhaust-temperature  disappears from the InfoCenter screen.

Parked or Recovery Regeneration

- When the engine computer requests either a parked regeneration or a recovery regeneration, the regeneration request icon (Figure 39) displays in the InfoCenter.

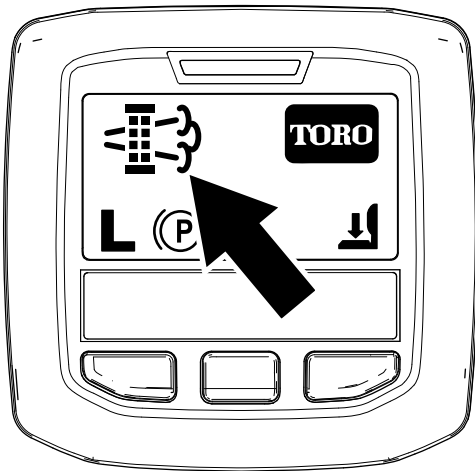

Figure 39

g224404

- The machine does not automatically perform a parked regeneration or a recovery regeneration, you must run the regeneration through the InfoCenter.

Parked Regeneration Messages

When a parked regeneration is requested by the engine computer the following messages display in the InfoCenter:

- Engine warning SPN 3720, FMI 16 (Figure 40)

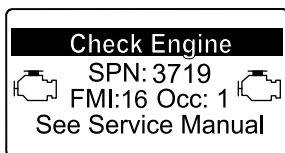

Figure 40

g318158

- Parked regeneration required ADVISORY #188 (Figure 41)

Note: Advisory #188 displays every 15 minutes.

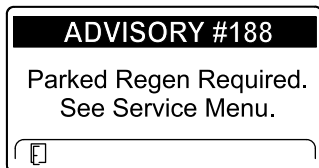

Figure 41

g224397

- If you do not perform a parked regeneration within 2 hours, the InfoCenter displays parked

regeneration required—power takeoff disabled
ADVISORY #189 (Figure 42).

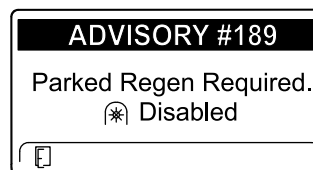

Figure 42

g224398

Important: Perform a parked regeneration to restore the PTO function; refer to [Preparing to Perform a Parked or Recovery Regeneration \(page 41\)](#) and [Performing a Parked or Recovery Regeneration \(page 41\)](#).

Note: The Home screen displays the PTO disabled Icon (Figure 43).

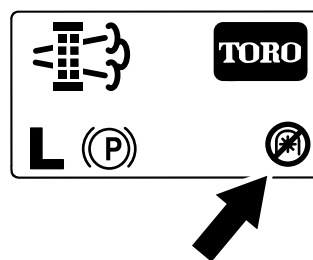

Figure 43

g224415

Recovery Regeneration Messages

When a recovery regeneration is requested by the engine computer, the following messages display in the InfoCenter:

- Engine warning SPN 3719, FMI: 0 (Figure 44)

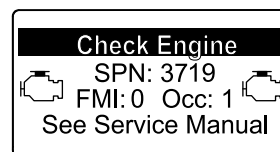

Figure 44

g213867

- Engine warning SPN 522574, FMI: 0 (Figure 45)

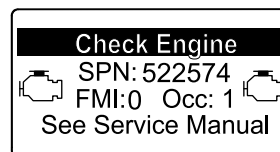

Figure 45

g318159

- Recovery regeneration required—power takeoff disabled ADVISORY #190 (Figure 46)

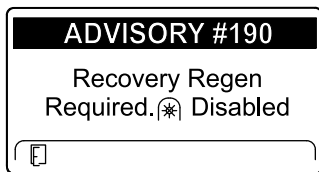

Figure 46

g224399

Important: Perform a recovery regeneration to restore the PTO function; refer to [Preparing to Perform a Parked or Recovery Regeneration \(page 41\)](#) and [Performing a Parked or Recovery Regeneration \(page 41\)](#).

Note: The Home screen displays the PTO disabled icon; refer to [Figure 43 in Parked Regeneration Messages \(page 40\)](#).

DPF Status-Limitation

- If the engine computer requests a recovery regeneration or is processing a recovery regeneration and you scroll down to the PARKED REGEN option, parked regeneration locks and the lock icon ([Figure 47](#)) appears in the lower right corner of the InfoCenter.

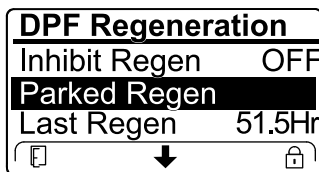

Figure 47

g224625

- If the engine computer has not requested a recovery regeneration and you scroll down to the RECOVERY REGEN option, the recovery regeneration locks and the lock icon ([Figure 48](#)) appears in the lower right corner of the InfoCenter.

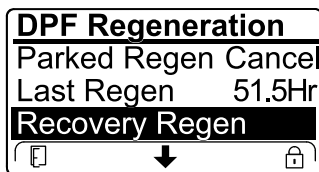

Figure 48

g224628

Preparing to Perform a Parked or Recovery Regeneration

- Ensure that the machine has fuel in the tank for the type of regeneration you are performing:
 - Parked Regeneration:** Ensure that you have 1/4 tank of fuel before performing the parked regeneration.
 - Recovery Regeneration:** Ensure that you have 1/2 tank of fuel before performing the recovery regeneration.
- Move the machine outside to an area away from combustible materials.
- Park the machine on a level surface.
- Ensure that the traction control or motion-control levers are in the NEUTRAL position.
- If applicable, shut off the PTO, and lower the cutting units or accessories.
- Engage the parking brake.
- Set the throttle to the low IDLE position.

Performing a Parked or Recovery Regeneration

⚠ CAUTION

The exhaust temperature is hot (approximately 600°C (1,112°F) during DPF regeneration. Hot exhaust gas can harm you or other people.

- Never operate the engine in an enclosed area.
- Make sure that there are no flammable materials around the exhaust system.
- Never touch a hot exhaust system component.
- Never stand near or around the exhaust pipe of the machine.

Important: The computer of the machine cancels DPF regeneration if you increase the engine speed from low idle or release the parking brake.

- Access the DPF Regeneration menu, press the center button to scroll down to either the PARKED REGEN START option or the RECOVERY REGEN START option ([Figure 49](#)), and press the right button to select the start the regeneration ([Figure 49](#)).

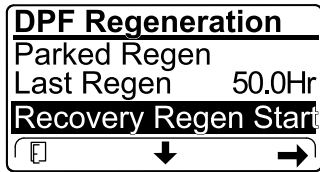
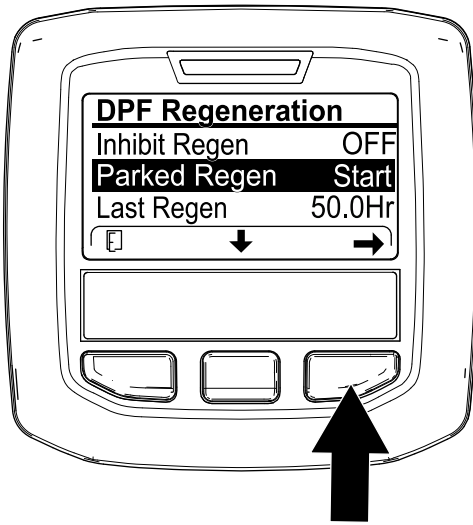

Figure 49

g224402

g224629

- At the DPF checklist screen, verify that the parking brake is engaged and that the engine speed is set to low idle (Figure 51).

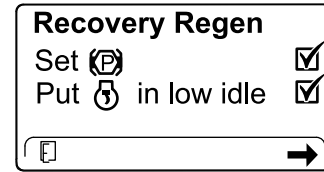
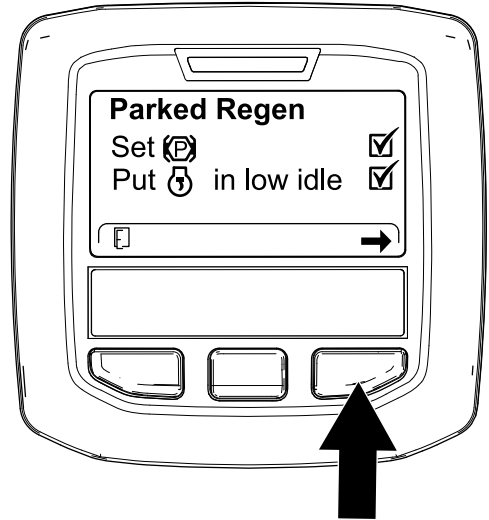

Figure 51

g224407

g227679

- At the VERIFY FUEL LEVEL screen, verify that you have 1/4 tank of fuel if you are performing the parked regeneration or 1/2 tank of fuel if you are performing the recovery regeneration, and press the right button to continue (Figure 50).

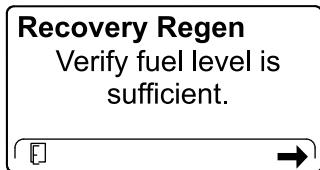
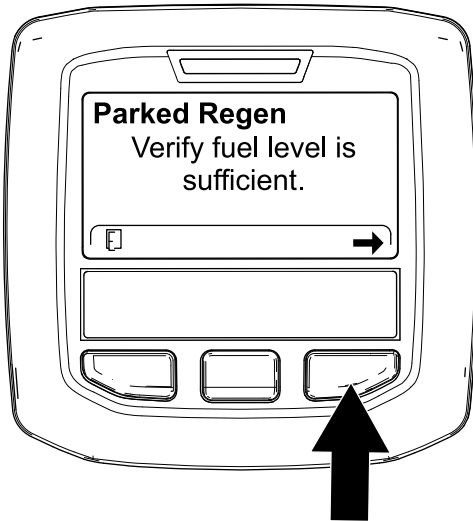

Figure 50

g224414

g227678

- At the INITIATE DPF REGEN screen, press the right button to continue (Figure 52).

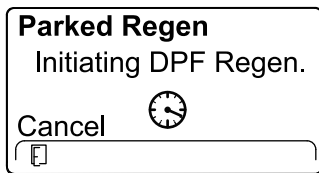

Figure 52

g224626

g224630

5. The InfoCenter displays the INITIATING DPF REGEN message (Figure 53).



g224411

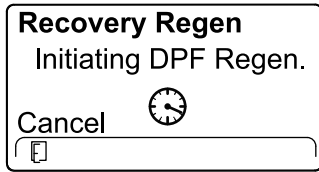

g227681

Figure 53

6. The InfoCenter displays the time to complete message (Figure 54).

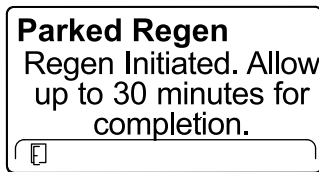

g224406

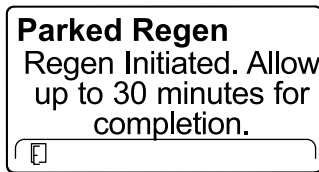

g224406

Figure 54

7. The engine computer checks the engine state and fault information. The InfoCenter may display the following messages found in the table that follows:

Note: If you attempt to do a forced parked regeneration before 50 hours of the last successful regeneration this message will appear. If the machine is requesting a regeneration and this message appears contact your authorized Toro distributor for service.

Check Message and Corrective Action Table

<p>Corrective Action: Exit the regeneration menu and run the machine until the time since last regeneration is greater than 50 hours; refer to Time Since Last Regeneration (page 36).</p>

Check Message and Corrective Action Table (cont'd.)

<p>Corrective Action: Troubleshoot the engine fault and retry DPF regeneration.</p>	
<p>Corrective Action: Start and run the engine.</p>	
<p>Corrective Action: Run the engine to warm the coolant temperature to 60°C (140°F).</p>	
<p>Corrective Action: Change the engine speed to low idle.</p>	
<p>Corrective Action: Troubleshoot the engine computer condition and retry DPF regeneration.</p>	

8. The InfoCenter displays the home screen and the regeneration acknowledge icon (Figure 55) appears in the lower right corner of the screen as the regeneration processes.

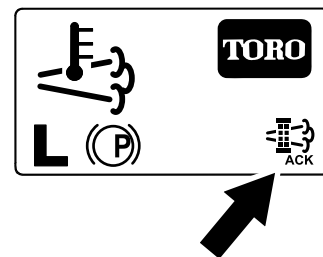



Figure 55

g224403

Note: While the DPF regeneration runs, the InfoCenter displays the high

exhaust-temperature icon .

9. When the engine computer completes a parked or recovery regeneration, the InfoCenter displays ADVISORY #183 (Figure 56). Press the left button to exit to the home screen.

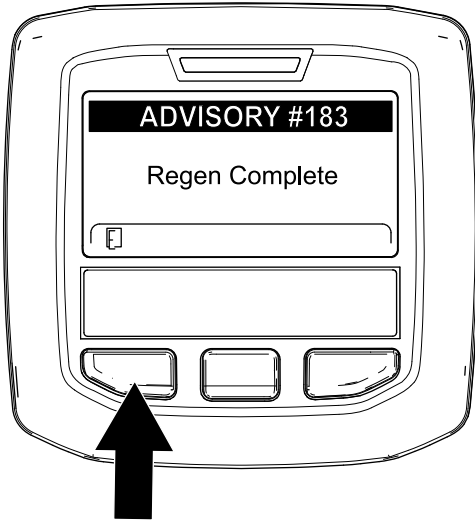

Figure 56

g224392

Note: If the regeneration fails to complete, the InfoCenter displays Advisory #184 (Figure 57). Press the left button to exit to the home screen.

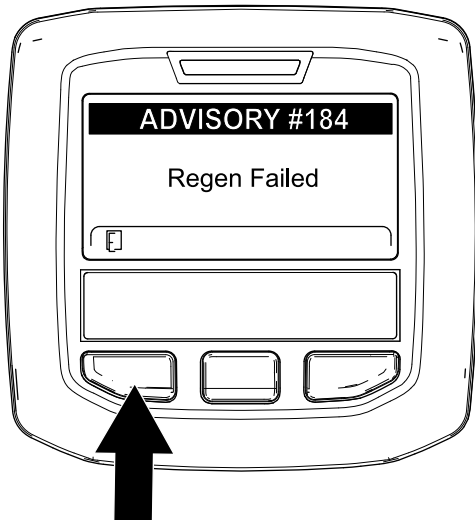

Figure 57

g224393

Canceling a Parked or Recovery Regeneration

Use the Parked Regen Cancel or Recovery Regen Cancel setting to cancel a running parked or recovery regeneration process.

1. Access the DPF Regeneration menu (Figure 58).

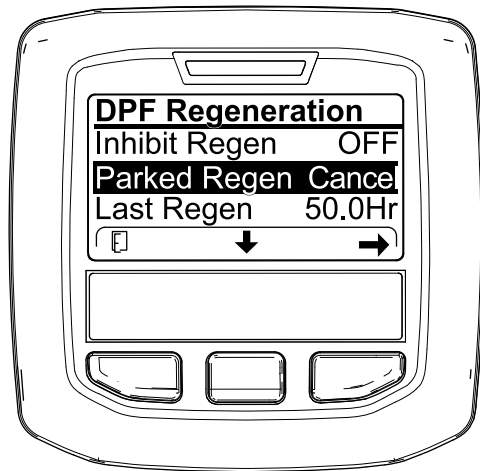

Figure 58

g227305

2. Press the center button to scroll down to the PARKED REGEN CANCEL (Figure 58) or the RECOVERY REGEN CANCEL option (Figure 59).

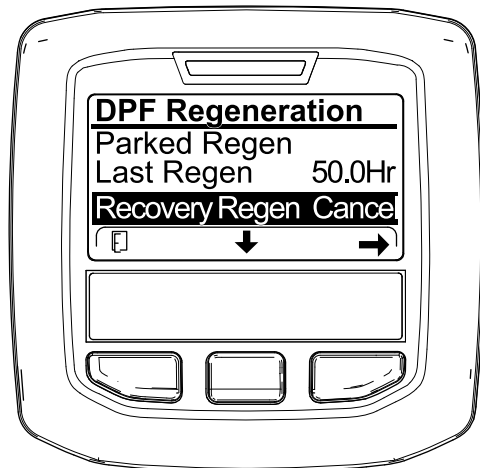

Figure 59

g227306

3. Press the right button to select the Regen Cancel entry (Figure 58 or Figure 59).

Operating Tips

Becoming Familiarized with the Machine

Before mowing grass, practice operating the machine in an open area. Start and shut off the engine. Operate in forward and reverse. Lower and raise the cutting decks and engage and disengage the cutting units. When you feel familiar with the machine, practice operating up and down slopes at different speeds.

Selecting the Proper Height-of-Cut Setting to Suit Conditions

Remove no more than approximately 25 mm (1 inch), or 1/3 of the grass blade when cutting. In exceptionally lush and dense grass, you may need to raise your height-of-cut setting.

Mowing

Turn the key in the ignition switch to the ON position, start the engine, and move the throttle to the FAST position. Move the Enable/Disable switch to the ENABLE position and use the Lower Mow/Raise lever to control the cutting decks. To move forward and cut grass, press the traction pedal forward.

Note: Allow the engine to idle for 5 minutes before shutting it off after a full load operation. Failure to do so may lead to turbo-charger trouble.

Mowing with Sharp Blades

A sharp blade cuts cleanly and without tearing or shredding the grass blades. A dull blade, which tears and shreds grass, causes grass to turn brown at the edges. This impairs grass growth and increases susceptibility to diseases. Ensure that the blade is in good condition and that there is a full sail.

Checking the Cutting Unit Condition

Ensure that the chambers of each cutting unit are in good condition. Straighten any chamber-component bends to ensure the correct blade tip/chamber clearance.

Checking the Mower Housing After Operating

To ensure that optimum performance is met, clean the underside of mower housing. If you allow residue to

build up in mower housing, cutting performance will decrease.

Transporting the Machine Between Jobs

Move the Enable/Disable switch to the DISABLE position and raise the cutting units to the TRANSPORT position. Move the Mow/Transport lever to the TRANSPORT position. Be careful when driving between objects so you do not accidentally damage the machine or cutting units. Use extra care when operating the machine on slopes; refer to [Slope Safety \(page 31\)](#).

After Operation

General Safety

- Shut off the engine, remove the key (if equipped), and wait for all movement to stop before you leave the operator's position. Allow the machine to cool before adjusting, servicing, cleaning, or storing it.
- Clean grass and debris from the cutting units, mufflers, and engine compartment to help prevent fires. Clean up oil or fuel spills.
- If the cutting units are in the transport position, use the positive mechanical lock (if available) before you leave the machine unattended.
- Allow the engine to cool before storing the machine in any enclosure.
- Remove the key and shut off the fuel (if equipped) before storing or hauling the machine.
- Never store the machine or fuel container where there is an open flame, spark, or pilot light, such as on a water heater or on other appliances.
- Maintain and clean the seat belt(s) as necessary

Identifying the Tie-Down Points

- **Front of the machine**—the hole in the rectangular pad, under the axle tube, inside each front tire (Figure 60).

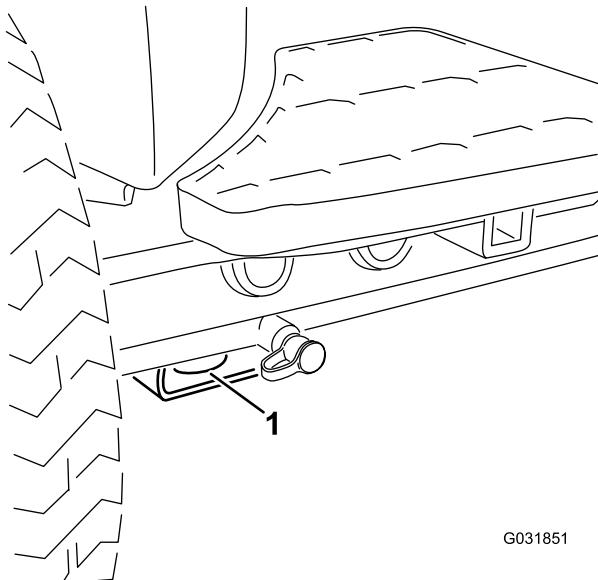

G031851

g031851

Figure 60

1. Front tie-down

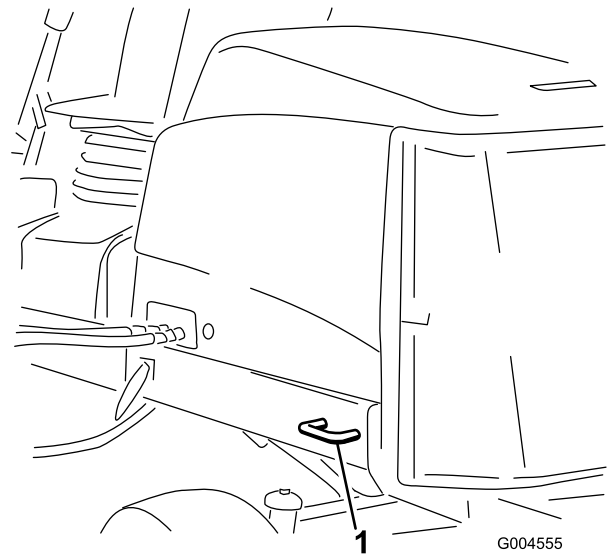

G004555

g004555

Figure 61

1. Rear tie-down

Hauling the Machine

- Remove the key and shut off the fuel (if equipped) before storing or transporting the machine.
- Use care when loading or unloading the machine into a trailer or a truck.
- Use full-width ramps for loading the machine into a trailer or a truck.
- Tie the machine down securely.

- **Rear of the machine**—each side of the machine on the rear frame (Figure 61).

Pushing or Towing the Machine

In an emergency, you can move the machine forward by actuating the bypass valve in the variable-displacement hydraulic pump and pushing or towing the machine.

Important: Do not push or tow the machine faster than 3 to 4.8 km/h (2 to 3 mph). If you push or tow at a faster speed, internal transmission damage may occur.

The bypass valves must be open whenever you push or tow the machine.

1. Locate the bypass valve on the left side of the hydrostat (Figure 62).

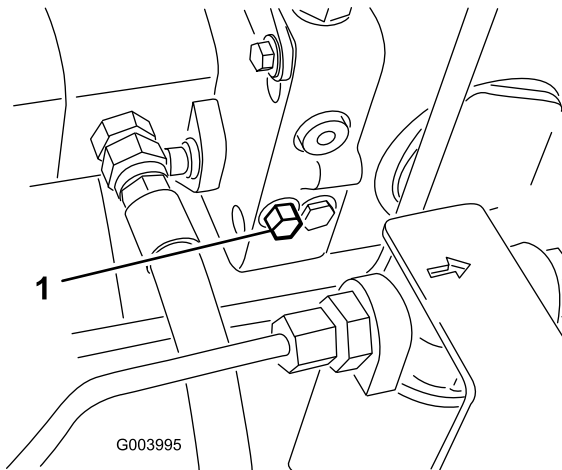

Figure 62

g003995

1. Bypass valve

-
2. Loosen the bolt 1-1/2 turns to allow the oil to bypass internally.

Note: Because the fluid is bypassed, the machine can be moved slowly without damaging the transmission.

3. Push or tow the machine.
4. Finish pushing or towing the machine and close the bypass valve. Torque the valve to 11 N·m (5 to 8 ft-lb).

Important: Ensure that the bypass valve is closed before you start the engine. Running the engine with an open bypass valve causes the transmission to overheat.

Maintenance

Note: Determine the left and right sides of the machine from the normal operating position.

Maintenance Safety

- Before you leave the operator’s position, do the following:
 - Park the machine on a level surface.
 - Disengage the power takeoff and lower the attachments.
 - Engage the parking brake.
 - Shut off the engine and remove the key.
 - Wait for all movement to stop.
- If you leave the key in the switch, someone could accidentally start the engine and seriously injure you or other bystanders. Remove the key from the switch before you perform any maintenance.
- Allow machine components to cool before performing maintenance.
- If the cutting units are in the transport position, use the positive mechanical lock (if equipped) before you leave the machine unattended.
- If possible, do not perform maintenance while the engine is running. Keep away from moving parts.
- Support the machine with jack stands whenever you work under the machine.
- Carefully release pressure from components with stored energy.
- Keep all parts of the machine in good working condition and all hardware tightened, especially blade-attachment hardware.
- Replace all worn or damaged decals.
- To ensure safe, optimal performance of the machine, use only genuine Toro replacement parts. Replacement parts made by other manufacturers could be dangerous, and such use could void the product warranty.

Recommended Maintenance Schedule(s)

Maintenance Service Interval	Maintenance Procedure
After the first hour	<ul style="list-style-type: none"> • Torque the wheel-lug nuts to 94 to 122 N·m (70 to 90 ft-lb).
After the first 10 hours	<ul style="list-style-type: none"> • Torque the wheel-lug nuts to 94 to 122 N·m (70 to 90 ft-lb). • Check the alternator-belt tension.
After the first 50 hours	<ul style="list-style-type: none"> • Change the engine oil and filter.
Before each use or daily	<ul style="list-style-type: none"> • Check the tire pressure. • Check the operation of the safety-interlock switches. • Check the blade stopping time. • Check the engine-oil level. • Drain water or other contaminants from the fuel filter/water separator. • Check the level of coolant in the expansion tank and clean debris off the screen, oil cooler, and front of the radiator. • Remove debris from the screen and radiator/oil cooler (more frequently in dirty operating conditions). • Check the hydraulic fluid level. • Check the hydraulic lines and hoses for leaks, kinked lines, loose mounting supports, wear, loose fittings, weather deterioration, and chemical deterioration. • Clean the machine. • Clean and maintain the seatbelt.
Every 50 hours	<ul style="list-style-type: none"> • Grease the bearings and bushings (immediately after every washing regardless of the interval listed). • Check the condition of and clean the battery. • Check the battery cable connections.
Every 100 hours	<ul style="list-style-type: none"> • Inspect the cooling system hoses. • Check the alternator-belt tension.

Maintenance Service Interval	Maintenance Procedure
Every 250 hours	<ul style="list-style-type: none"> • Torque the wheel-lug nuts to 94 to 122 N·m (70 to 90 ft-lb). • Change the engine oil and filter.
Every 400 hours	<ul style="list-style-type: none"> • Service the air cleaner. (Or earlier if the air-cleaner indicator illuminates red. Service it more frequently in extremely dirty or dusty conditions.) • Replace the fuel filter. • Inspect the fuel lines and connections. • Replace the fuel-filter canister.
Every 800 hours	<ul style="list-style-type: none"> • Drain and clean the fuel tank. • Check the rear wheel toe-in. • If you are not using the recommended hydraulic fluid or have ever filled the reservoir with an alternative fluid, change the hydraulic fluid. • If you are not using the recommended hydraulic fluid or have ever filled the reservoir with an alternative fluid, replace the hydraulic filter (sooner if the service interval indicator is in the red zone). • Pack the rear-wheel bearings.
Every 1,000 hours	<ul style="list-style-type: none"> • If you are using the recommended hydraulic fluid, replace the hydraulic filter (sooner if the service interval indicator is in the red zone).
Every 2,000 hours	<ul style="list-style-type: none"> • If you are using the recommended hydraulic fluid, change the hydraulic fluid.
Every 3,000 hours	<ul style="list-style-type: none"> • Disassemble, clean, and assemble the soot filter of the DPF. or clean the soot filter if engine faults SPN 3720 FMI 16 or SPN 3720 FMI 0 display in the InfoCenter.
Before storage	<ul style="list-style-type: none"> • Drain and clean the fuel tank.
Every 2 years	<ul style="list-style-type: none"> • Flush and replace the cooling system fluid. • Drain and flush the hydraulic tank. • Replace the hydraulic hoses. • Replace all moving hoses.

Important: If you are performing maintenance on the machine and run the engine with an engine exhaust-extraction duct, set the inhibit regen setting to ON; refer to [Setting the Inhibit Regen \(page 38\)](#).

Daily Maintenance Checklist

Duplicate this page for routine use.

Maintenance Check Item	For the week of:						
	Mon.	Tues.	Wed.	Thurs.	Fri.	Sat.	Sun.
Check the safety-interlock operation.							
Check the brake operation.							
Check the engine oil and fuel level.							
Drain the water/fuel separator.							
Check the air-filter-restriction indicator.							
Check the radiator and screen for debris.							
Check unusual engine noises. ¹							
Check unusual operating noises.							
Check the hydraulic-system-fluid level.							
Check the hydraulic-filter indicator. ²							
Check hydraulic hoses for damage.							
Check for fluid leaks.							
Check the tire pressure.							
Check the instrument operation.							
Check the height-of-cut adjustment.							
Check the condition of the blades.							
Check all grease fittings for lubrication. ³							
Touch-up damaged paint.							

1. Check the glow plug and injector nozzles if hard starting, excess smoke, or rough running is noted.
 2. Check with the engine running and the oil at operating temperature
 3. Immediately after every washing, regardless of the interval listed

Notation for Areas of Concern

Inspection performed by:		
Item	Date	Information
1		
2		
3		
4		
5		
6		
7		
8		

Important: Refer to your engine owner's manual for additional maintenance procedures.

Note: Download a free copy of the electrical or hydraulic schematic by visiting www.Toro.com and searching for your machine from the Manuals link on the home page.

Pre-Maintenance Procedures

Raising the Machine

Use the following as points to jack up the machine:

- **Front of the machine**—rectangular pad, under the axle tube, inside each front tire ([Figure 63](#)).

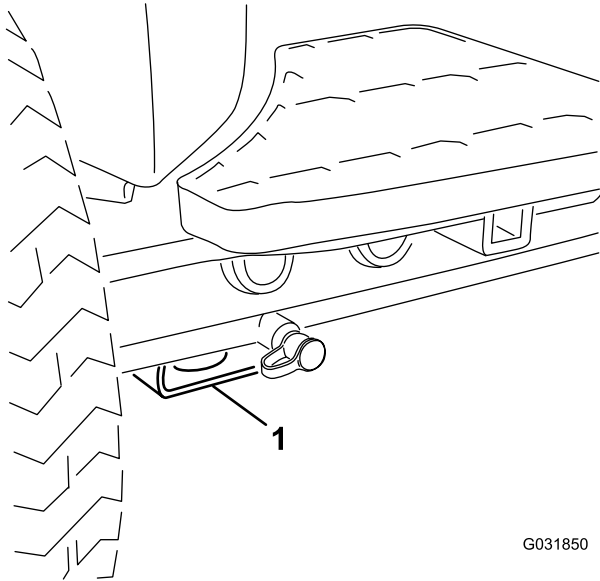

G031850

g031850

Figure 63

1. Front jacking point

- **Rear of the machine**—rectangular axle tube on the rear axle.

Lubrication

Greasing the Bearings and Bushings

If you operate the machine under normal conditions, use No. 2 lithium grease to lubricate all bearings and bushings at the specified maintenance interval. Lubricate bearings and bushings **immediately** after every washing, regardless of the interval listed.

The grease fitting locations and quantities are as follows:

- Pump driveshaft U-joint (3)—[Figure 64](#)

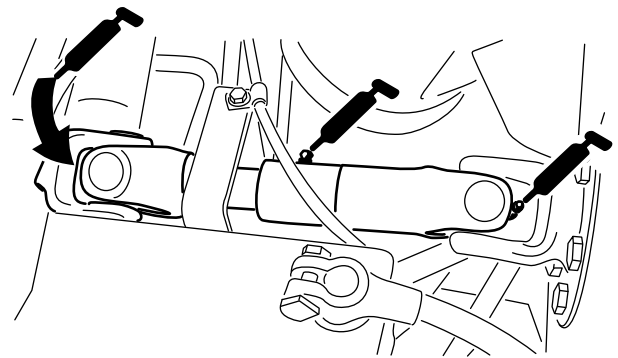

g003962

Figure 64

- Cutting unit lift-arm cylinders (2 each)—[Figure 65](#)

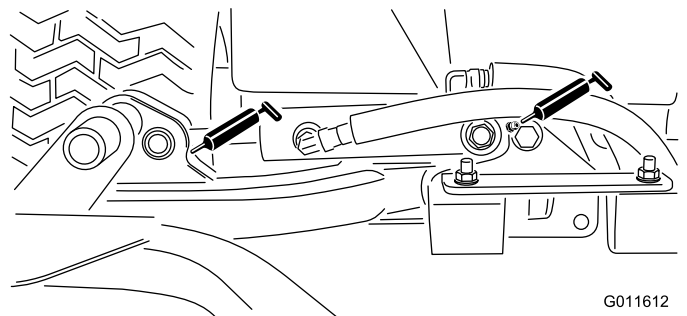

G011612

g011612

Figure 65

- Lift-arm pivots (1 each)—[Figure 65](#)

- Cutting unit carrier-frame pivot (1 each)—[Figure 66](#)

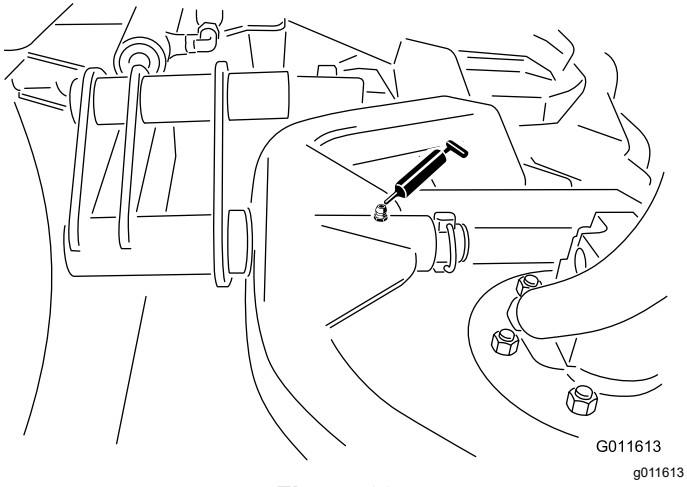

Figure 66

- Steering-cylinder ball joints (2) and rear axle (1)—[Figure 69](#)

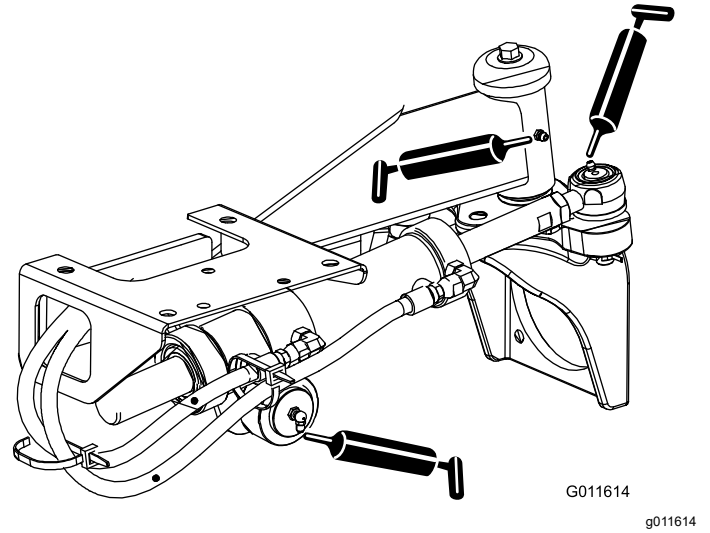

Figure 69

- Lift-arm pivot shaft (1 each)—[Figure 67](#)

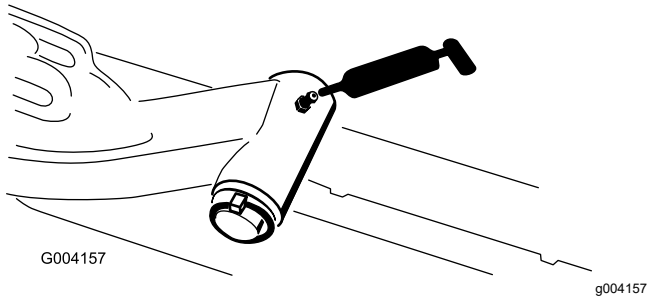

Figure 67

- Brake pedal (1)—[Figure 70](#)

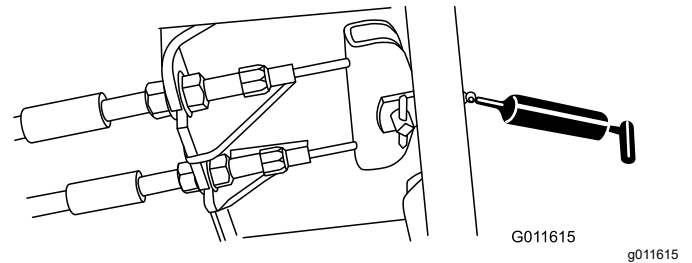

Figure 70

- Axle-steering pivot (1)—[Figure 68](#)

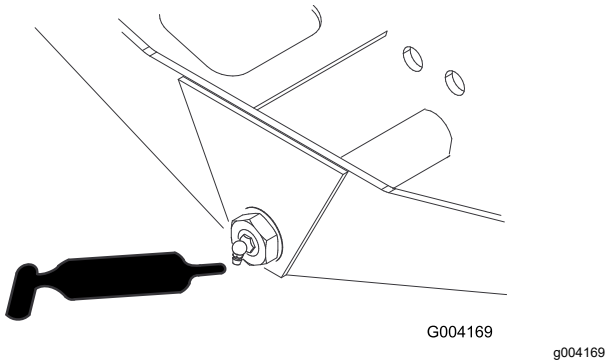

Figure 68

Engine Maintenance

Engine Safety

- Shut off the engine and remove the key before checking the oil or adding oil to the crankcase.
- Do not change the governor speed or overspeed the engine.

Servicing the Air Cleaner

Check the whole intake system for leaks, damage, or loose hose clamps. Do not use a damaged air filter.

Service the air-cleaner filter only when the service indicator requires it. Changing the air filter before it is necessary only increases the chance of dirt entering the engine when the filter is removed.

Important: Make sure that the cover is seated correctly, seals with the air-cleaner body, and the rubber outlet valve is in a downward position—between the 5 o'clock and 7 o'clock positions when viewed from the end.

- Cutting unit spindle-shaft bearings (2 per cutting unit)—[Figure 71](#)

Note: You can use either fitting, whichever is more accessible. Pump grease into the fitting until a small amount appears at bottom of the spindle housing (under the cutting unit).

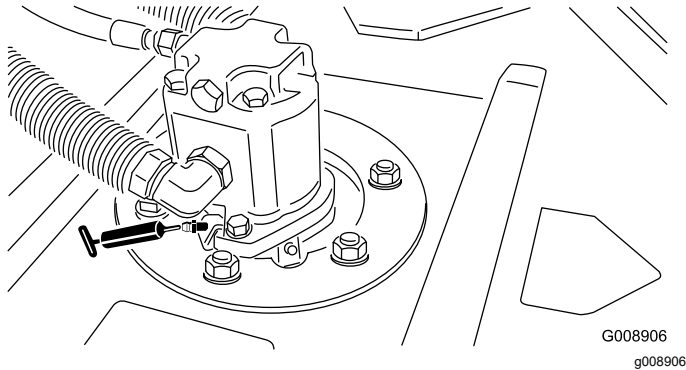

Figure 71

- Rear-roller bearings (2 per cutting unit)—[Figure 72](#)

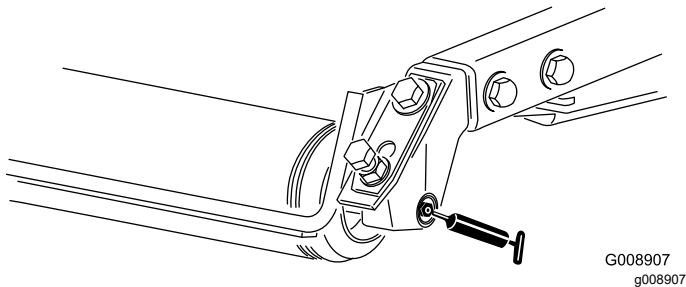
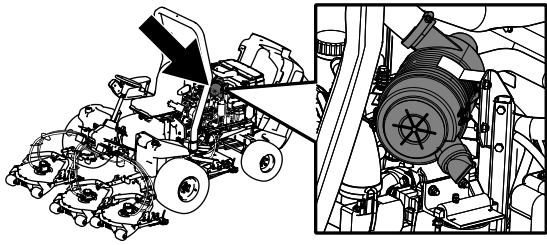

Figure 72

Note: Ensure that the grease groove in each roller mount aligns with the grease hole in each end of the roller shaft. To help align the groove and hole, there is also an alignment mark on 1 end of the roller shaft.



g194209

Servicing the Engine Oil

Oil Specification

Toro Premium Engine Oil is available from your authorized Toro distributor in either 15W-40 or 10W-30 viscosity grades.

Use high-quality, low-ash engine oil that meets or exceeds the following specifications:

- API service category CJ-4 or higher
- ACEA service category E6
- JASO service category DH-2

Important: Using engine oil other than API CJ-4 or higher, ACEA E6, or JASO DH-2 may cause the diesel particulate filter to plug or cause engine damage.

Use the following engine oil viscosity grade:

- Preferred oil: SAE 15W-40 (above 0°F)
- Alternate oil: SAE 10W-30 or 5W-30 (all temperatures)

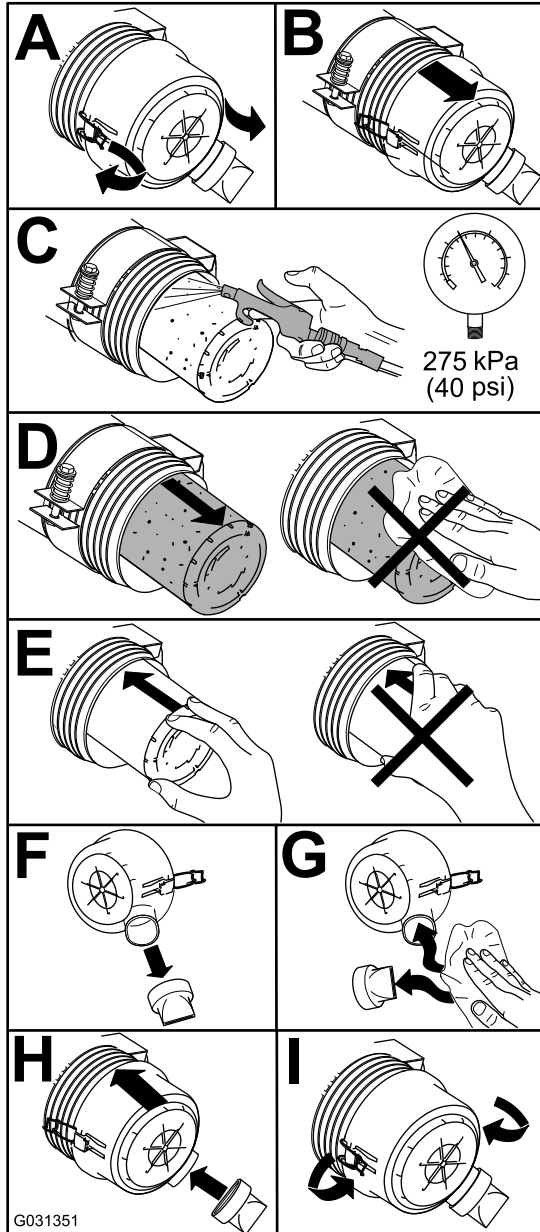

G031351

g031351

Figure 73

Checking the Engine-Oil Level

Service Interval: Before each use or daily

The engine is shipped with oil in the crankcase; however, the oil level must be checked before and after the engine is first started.

Important: Check the engine oil daily. If the engine-oil level is above the Full mark on the dipstick, the engine oil may be diluted with fuel; If the engine oil level is above the Full mark, change the engine oil.

The best time to check the engine oil is when the engine is cool before it has been started for the day. If it has already been run, allow the oil to drain back down to the sump for at least 10 minutes before checking. If the oil level is at or below the Add mark on the dipstick, add oil to bring the oil level to the Full mark. **Do not overfill the engine with oil.**

Important: Keep the engine oil level between the upper and lower limits on the dipstick; the engine may fail if you run it with too much or too little oil.

1. Park the machine on a level surface.
2. Check the engine-oil level (Figure 74).

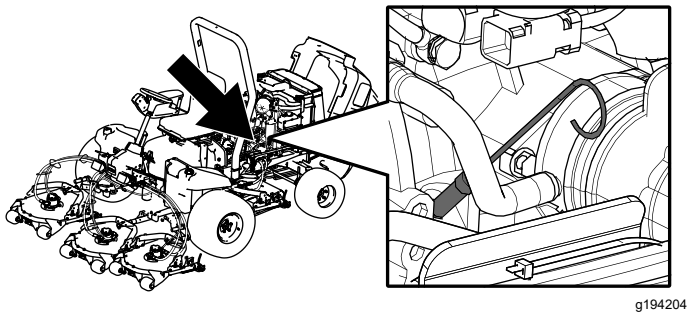

g194204

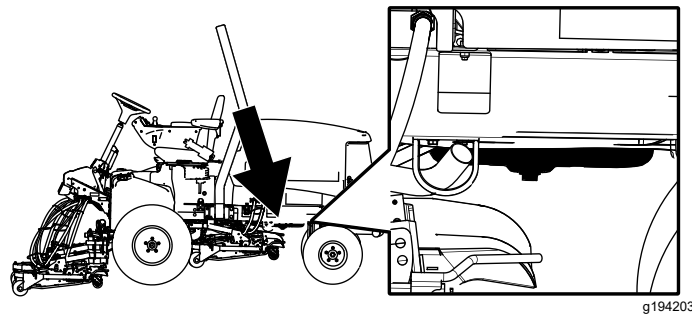

g194203

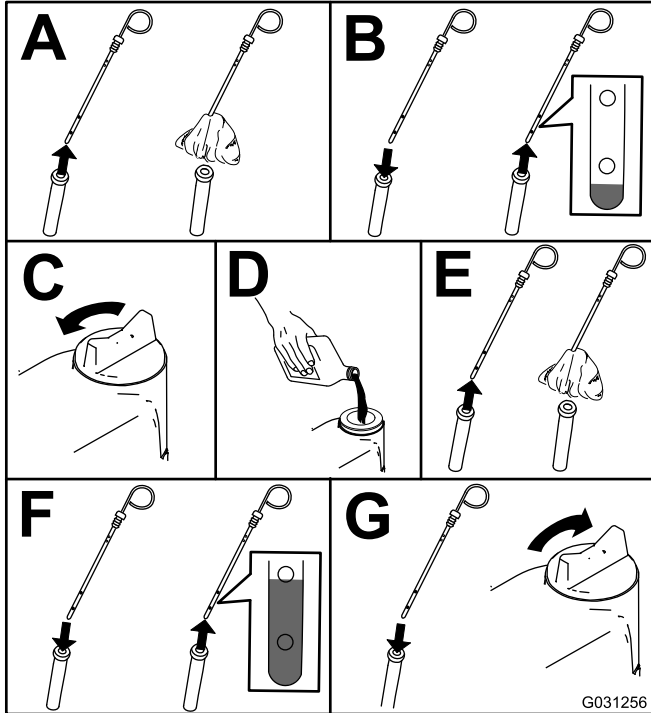

G031256

g031256

Figure 74

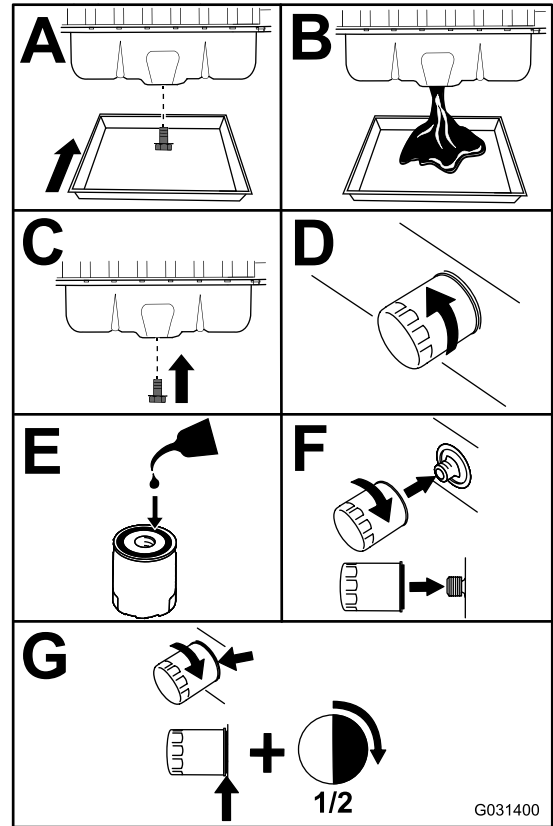

G031400

g031400

Figure 75

Note: When using different oil, drain all old oil from the crankcase before adding new oil.

Crankcase Oil Capacity

Approximately 5.2 L (5.5 US qt) with the filter.

Changing the Engine Oil and Filter

Service Interval: After the first 50 hours

Every 250 hours

1. Start the engine and let it run 5 minutes to allow the oil to warm up.
2. With the machine parked on a level surface, shut off the engine, remove the key, and wait for all moving parts to stop before leaving the operating position.
3. Replace the engine oil and filter (Figure 75).

4. Add oil to the crankcase.

Fuel System Maintenance

Servicing the Fuel Filter

Service Interval: Every 400 hours—Replace the fuel filter.

1. Clean the area around the fuel-filter head (Figure 76).

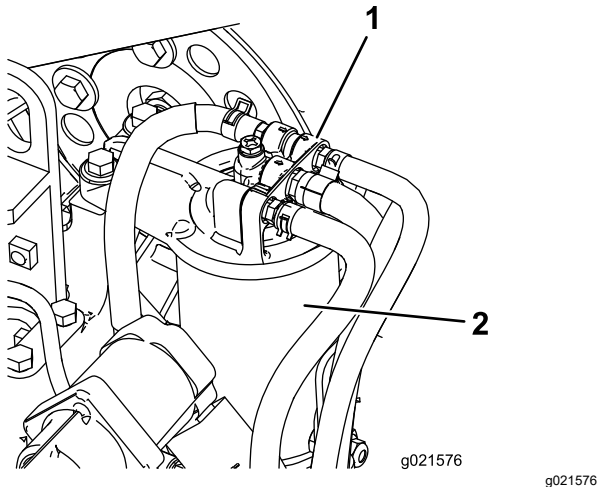

Figure 76

1. Fuel-filter head
 2. Fuel filter
-
2. Remove the filter and clean the filter head mounting surface (Figure 76).
 3. Lubricate the filter gasket with clean lubricating engine oil. Refer to the *Engine Operator's Manual* for additional information.
 4. Install the dry filter canister by hand, until the gasket contacts the filter head, then rotate it an additional 1/2 turn.
 5. Start the engine and check for fuel leaks around the filter head.

Inspecting the Fuel Lines and Connections

Service Interval: Every 400 hours/Yearly (whichever comes first)

Inspect the fuel lines for deterioration, damage, or loose connections.

Servicing the Fuel-Pickup Tube

The fuel-pickup tube, located inside the fuel tank, is equipped with a screen to help prevent debris from

entering the fuel system. Remove the fuel-pickup tube and clean screen as required.

Servicing the Water Separator

Service Interval: Before each use or daily—Drain water or other contaminants from the fuel filter/water separator.

Every 400 hours—Replace the fuel-filter canister.

Service the water separator as shown in Figure 77.

After replacing the water separator, turn the key to ON for 10 seconds, but do not start the engine. Turn the key off and repeat this 2 more times.

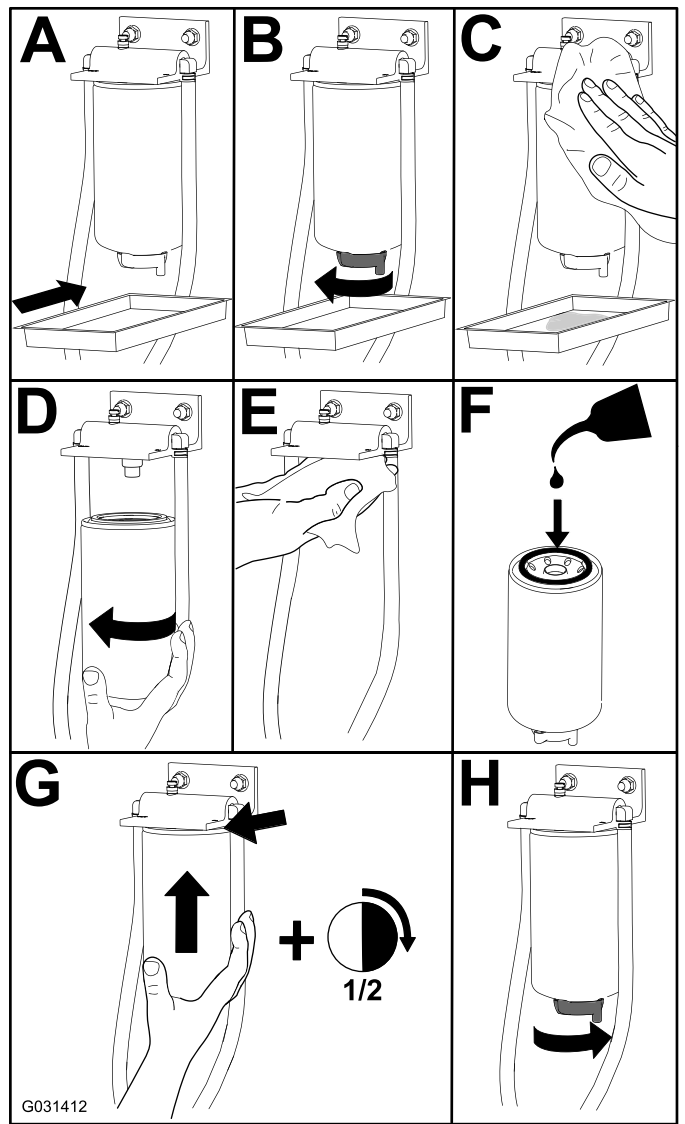

Figure 77

Draining the Fuel Tank

Service Interval: Every 800 hours—Drain and clean the fuel tank.

Before storage—Drain and clean the fuel tank.

In addition to the listed service interval, drain and clean the tank if the fuel system becomes contaminated or if you are storing the machine for an extended period. Use clean fuel to flush out the tank.

Servicing the Diesel-Oxidation Catalyst (DOC) and the Soot Filter

Service Interval: Every 3,000 hours or clean the soot filter if engine faults SPN 3720 FMI 16 or SPN 3720 FMI 0 display in the InfoCenter.

If engine faults CHECK ENGINE SPN 3251 FMI 0, CHECK ENGINE SPN 3720 FMI 0, or CHECK ENGINE SPN 3720 FMI 16 in the InfoCenter (Figure 78) display in the InfoCenter, clean the soot filter using the steps that follow:

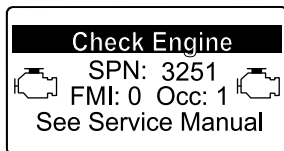

g214715

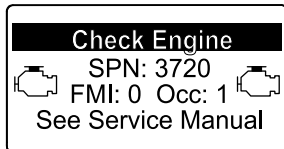

g213864

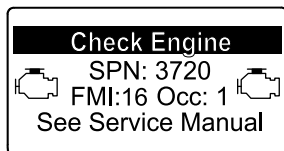

g213863

Figure 78

Priming the Fuel System

Prime the fuel system before starting the engine for the first time, after running out of fuel, or after fuel system maintenance (e.g., draining the filter/water separator, replacing a fuel hose).

1. Ensure that fuel is in the fuel tank.
2. Perform the following steps to prime the filter and the lines to the high pressure pump to prevent wear or damage to the pump:
 - A. Cycle the key to the ON position for 15 to 20 seconds.
 - B. Cycle the key to the OFF position for 30 to 40 seconds.

Note: This allows the ECU to power down.
 - C. Cycle the key to the ON position for 15 to 20 seconds.
 - D. Inspect for leaks around the filter and hoses.

Important: Do not use the engine starter motor to crank the engine to prime the fuel system.

1. Refer to the Engine section in the *Service Manual* for information on disassembling and assembling the diesel-oxidation catalyst and the soot filter of the DPF.
2. Refer to your authorized Toro distributor for diesel-oxidation catalyst and the soot filter replacement parts or service.
3. Contact your authorized Toro distributor to have them reset the engine ECU after you install a clean DPF.

Electrical System Maintenance

Electrical System Safety

- Disconnect the battery before repairing the machine. Disconnect the negative terminal first and the positive last. Connect the positive terminal first and the negative last.
- Charge the battery in an open, well-ventilated area, away from sparks and flames. Unplug the charger before connecting or disconnecting the battery. Wear protective clothing and use insulated tools.

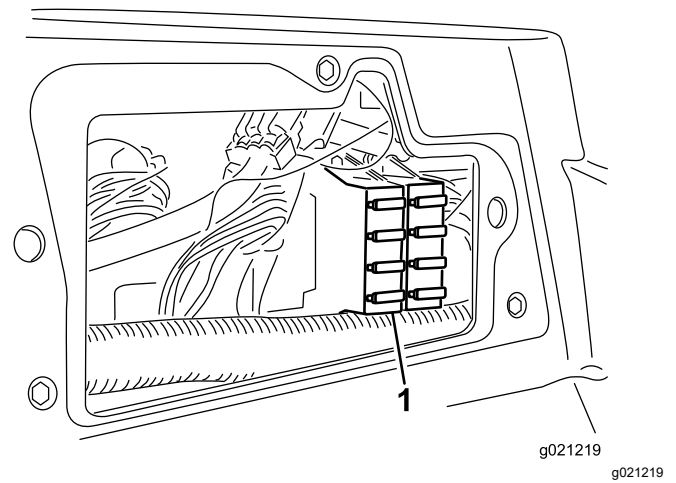

Figure 79

1. Fuse block

Servicing the Battery

Service Interval: Every 50 hours

Perform the following tasks to service the battery:

- Check the battery condition
- Clean the battery (if necessary)
Note: To clean the battery, wash the entire case with a solution of baking soda and water. Rinse it with clear water.
- Check the battery-cable connections and coat the battery posts and cable connectors with Grafo 112X (skin-over) grease or petroleum jelly to prevent corrosion.

Important: Before welding on the machine, disconnect the negative cable from the battery to prevent damage to the electrical system. Also, you must disconnect the engine, InfoCenter, and machine controllers before welding on the machine.

Locating the Fuses

There are 8 fuses in the electrical system. The fuse block (Figure 79) is located behind the control-arm-access panel. Refer to Figure 80 for a description of each fuse.

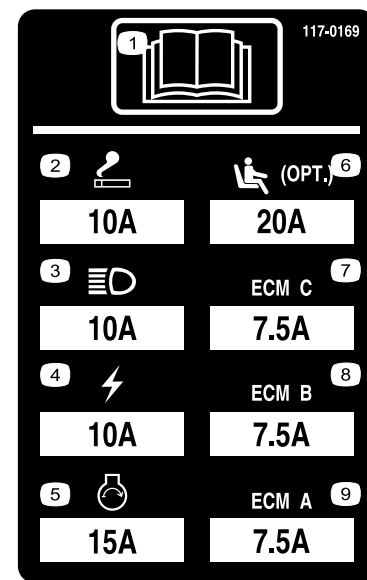

Figure 80

1. Read the *Operator's Manual*.
2. Power point (10 A)
3. Head lights (10 A)
4. Power (10 A)
5. Engine start (15 A)
6. Optional air ride seat suspension (20 A)
7. Engine computer management C (7.5 A)
8. Engine computer management B (7.5 A)
9. Engine computer management A (7.5 A)

Charging the Battery

⚠ WARNING

Charging the battery produces gasses that can explode.

Do not smoke near the battery, and keep sparks and flames away from the battery.

Important: Keep the battery fully charged. This is especially important to prevent battery damage when the temperature is below 0°C (32°F).

1. Clean the exterior of the battery case and the battery posts.
Note: Connect the leads of the battery charger to battery posts before connecting the charger to the electrical source.
2. Look at the battery and identify the positive and negative battery posts.
3. Connect the positive lead of the battery charger to the positive battery post (Figure 81).

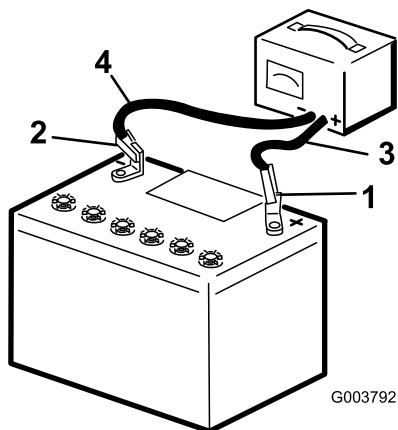

Figure 81

- | | |
|--------------------------|---------------------------|
| 1. Positive battery post | 3. Red (+) charger lead |
| 2. Negative battery post | 4. Black (-) charger lead |

4. Connect the negative lead of the battery charger to the negative-battery post (Figure 81).
5. Connect the battery charger to the electrical source, and charge the battery.

Important: Do not overcharge the battery.

6. When the battery is fully charged, unplug the charger from the electrical source, then disconnect the charger leads from the battery posts (Figure 81).

Drive System Maintenance

Adjusting the Traction Drive for Neutral

The machine must not creep when the traction pedal is released. If it does creep, adjust as follows:

1. Park the machine on a level surface, shut off the engine, and lower the cutting units to the ground.
2. Jack up the machine until all the tires are off the ground; refer to [Raising the Machine](#) (page 51). Support the machine with jack stands to prevent it from falling accidentally.
3. On the right side of the hydrostat, loosen the locknut on the traction-adjustment cam (Figure 82).

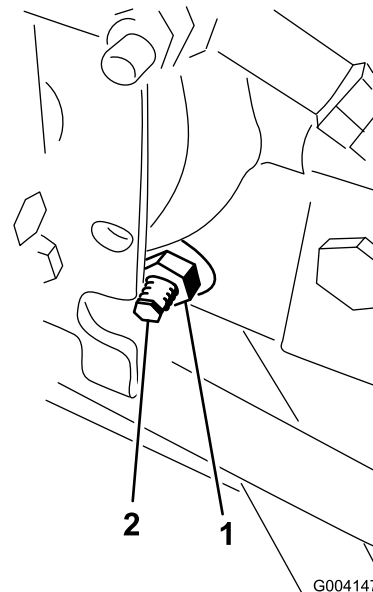

Figure 82

1. Locknut
2. Traction-adjustment cam

⚠ WARNING

The engine must be running so that you can make the final adjustment on the traction adjustment cam. This could cause personal injury.

Keep your hands, feet, face, and other body parts away from the muffler, other hot parts of the engine, and any rotating parts.

4. Turn the key in the switch to the ON position, start the engine, and rotate the cam hex in either direction until the wheels cease rotation.
5. Tighten the locknut to secure the adjustment.
6. Turn the key in the switch to the OFF position, remove the jack stands, and lower the machine to the ground.
7. Test drive the machine to make sure that it does not creep.

Adjusting the Rear Wheel Toe-in

Service Interval: Every 800 hours

1. Rotate the steering wheel so that the rear wheels are straight ahead.
2. Loosen the jam nut on each end of the tie rod (Figure 83).

Note: The end of the tie rod with the external groove is a left-hand thread.

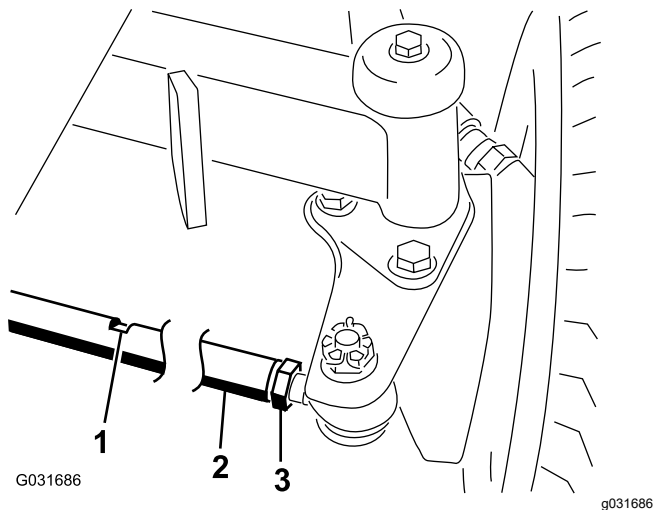

Figure 83

1. Wrench slot
 2. Tie rod
 3. Jam nut
3. Using the wrench slot, rotate the tie rod.
 4. Measure the distance at the front and rear of the rear wheels at axle height.

Note: The distance at the front of the rear wheels should be less than 6 mm (1/4 inch) of the distance measured at the rear of the wheels.
 5. Repeat procedure as required.

Cooling System Maintenance

Cooling System Safety

- Swallowing engine coolant can cause poisoning; keep out of reach from children and pets.
- Discharge of hot, pressurized coolant or touching a hot radiator and surrounding parts can cause severe burns.
 - Always allow the engine to cool at least 15 minutes before removing the radiator cap.
 - Use a rag when opening the radiator cap, and open the cap slowly to allow steam to escape.
- Do not operate the machine without the covers in place.
- Keep your fingers, hands, and clothing clear of the rotating fan and drive belt.

Coolant Specification

The coolant reservoir is filled at the factory with a 50/50 solution of water and ethylene glycol base extended-life coolant.

Important: Use only commercially available coolants that meet the specifications listed in the Extended Life Coolant Standards Table.

Do not use conventional (green) inorganic-acid technology (IAT) coolant in your machine. Do not mix conventional coolant with extended-life coolant.

Coolant Type Table

Ethylene-Glycol Coolant Type	Corrosion Inhibitor Type
Extended-life antifreeze	Organic-acid technology (OAT)

Important: Do not rely on the color of the coolant to identify the difference between conventional (green) inorganic-acid technology (IAT) coolant and extended-life coolant.

Coolant manufacturers may dye extended-life coolant in one of the following colors: red, pink, orange, yellow, blue, teal, violet, and green. Use coolant that meets the specifications in the Extended Life Coolant Standards Table.

Extended Life Coolant Standards

ATSM International	SAE International
D3306 and D4985	J1034, J814, and 1941

Important: Coolant concentration should be a 50/50 mixture of coolant to water.

- **Preferred:** When mixing coolant from a concentrate, mix it with distilled water.
- **Preferred option:** If distilled water is not available, use a pre-mix coolant instead of a concentrate.
- **Minimum requirement:** If distilled water and pre-mix coolant are not available, mix concentrated coolant with clean drinkable water.

Checking the Cooling System

Service Interval: Before each use or daily—Check the level of coolant in the expansion tank and clean debris off the screen, oil cooler, and front of the radiator.

The cooling system is filled with a 50/50 solution of water and permanent ethylene glycol antifreeze. The capacity of the cooling system is 9.5 L (10 US qt).

⚠ DANGER

The rotating fans and drive belts can cause personal injury.

- Do not operate the machine without the guards in place.
 - Keep your fingers, hands, and clothing clear of the rotating fan and drive belt.
 - Shut off the engine and remove the key before performing maintenance.
1. Check the level of coolant in the expansion tank (Figure 84).

Note: The coolant level should be between the marks on the side of the tank.

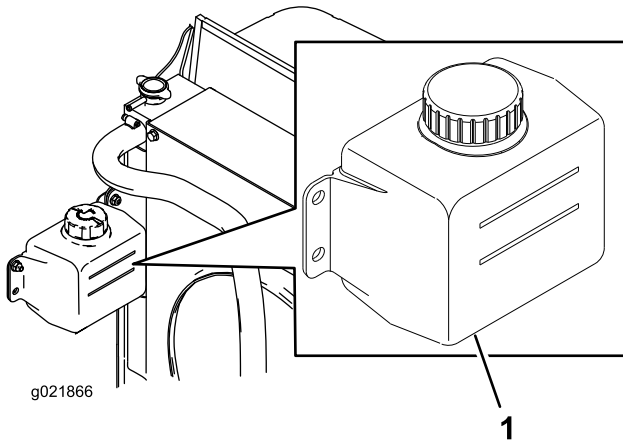

Figure 84

1. Expansion tank

2. If the coolant level is low, remove the expansion-tank cap and replenish the system. **Do not overfill.**

3. Install the expansion-tank cap.

Cleaning the Cooling System

Service Interval: Before each use or daily—Remove debris from the screen and radiator/oil cooler (more frequently in dirty operating conditions).

Every 100 hours—Inspect the cooling system hoses.

Every 2 years—Flush and replace the cooling system fluid.

Remove debris from the screen and radiator/oil cooler daily (clean more frequently in dirty conditions).

1. Turn the key in the ignition switch to the OFF position and remove the key.
2. Thoroughly clean all debris out of the engine area.
3. Unlatch the clamp and pivot open the rear screen (Figure 85).

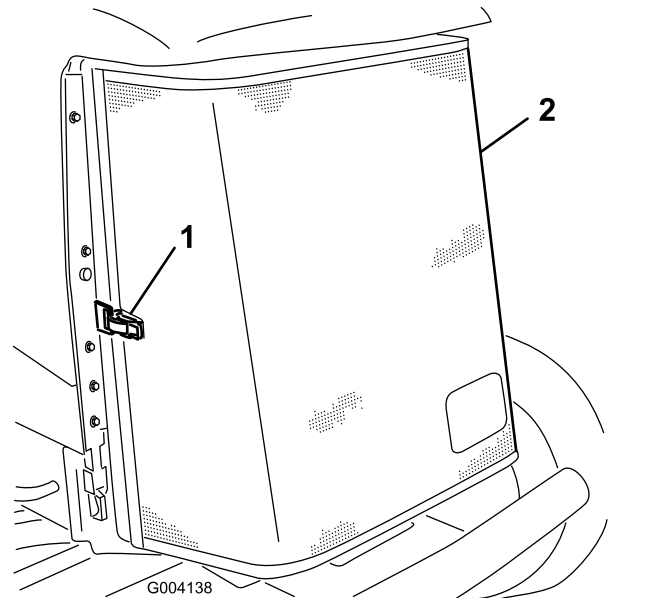

Figure 85

1. Rear screen latch
2. Rear screen

4. Thoroughly clean both sides of the radiator and oil cooler (Figure 86) with compressed air.

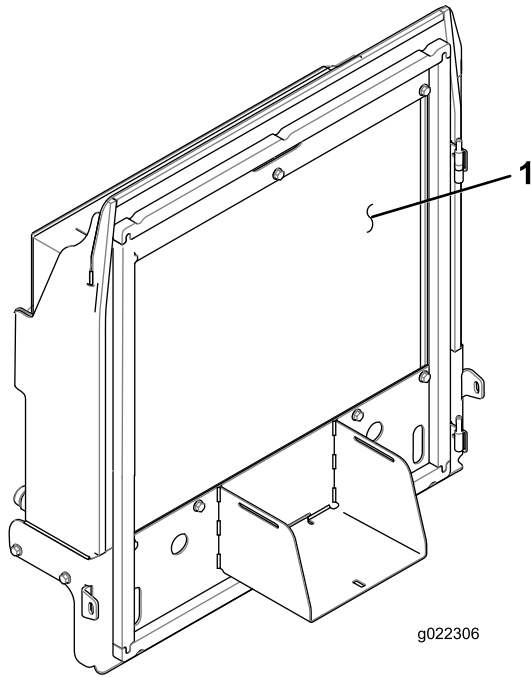

Figure 86

1. Radiator/oil cooler

5. Close the screen and secure the latch.

Brake Maintenance

Adjusting the Parking Brakes

Adjust the brakes when there is more than 2.5 cm (1 inch) of free travel (Figure 87) of the brake pedal, or when more holding force is required. Free travel is the distance the brake pedal moves before you feel braking resistance.

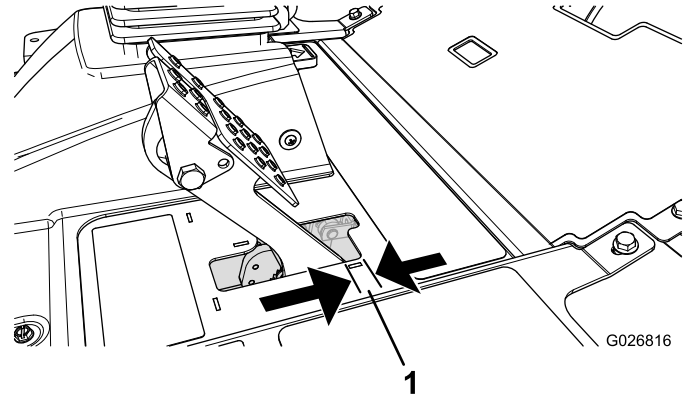

Figure 87

1. Free travel

Note: Use the wheel motor backlash to rock the drums back and forth to ensure that the drums are free prior to and after adjustment.

1. To reduce free travel of the brake pedals, tighten the brakes by loosening the front nut on the threaded end of the brake cable (Figure 88).

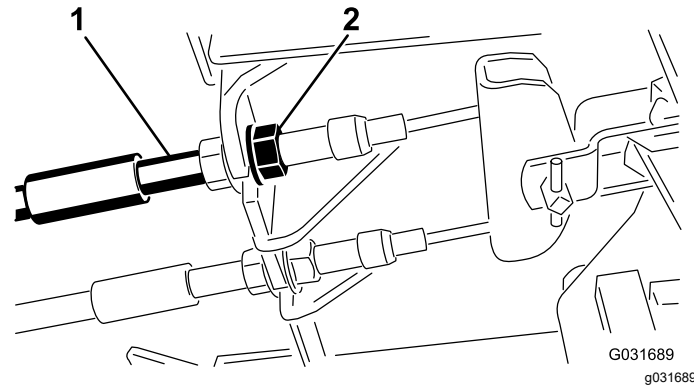

Figure 88

1. Brake cables
2. Front nuts

2. Tighten the rear nut to move the cable backward until brake pedals have 0.63 to 1.27 cm (1/4 to 1/2 inch) of free travel (Figure 87), before wheel lock up is achieved.
3. Tighten the front nuts, ensuring that both cables actuate the brakes simultaneously. Ensure

that the cable conduit does not rotate during tightening procedure.

Adjusting the Parking-Brake Latch

If the parking brake fails to engage and latch, an adjustment to the brake pawl is required.

1. Loosen the 2 screws securing the parking brake pawl to the frame (Figure 89).

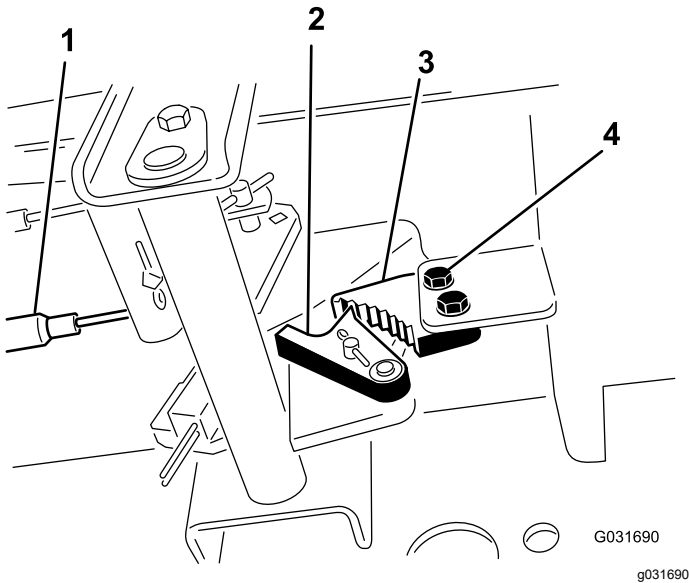

Figure 89

- | | |
|-----------------|-----------------------|
| 1. Brake cables | 3. Parking brake pawl |
| 2. Brake detent | 4. Screws (2) |

2. Press the parking brake pedal forward until the brake detent completely engages on the brake pawl (Figure 89).
3. Tighten the 2 screws locking the adjustment.
4. Press the brake pedal to disengage the parking brake.
5. Check the adjustment and adjust as required.

Belt Maintenance

Servicing the Alternator Belt

Service Interval: After the first 10 hours

Every 100 hours

Note: For proper belt tension, allow 10 mm (3/8 inch) deflection when a force of 44 N (10 lb) is applied on the belt midway between the pulleys.

1. If the deflection is not 10 mm (3/8 inch), loosen the alternator mounting bolts (Figure 90).

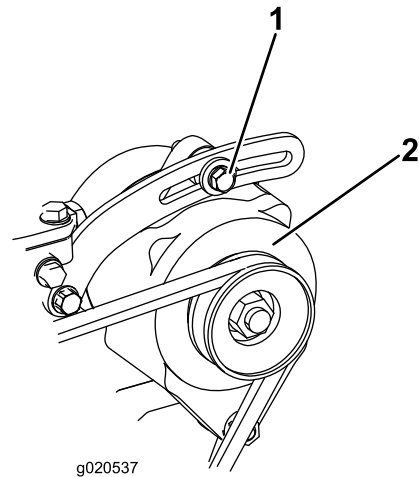

Figure 90

- | | |
|------------------|---------------|
| 1. Mounting bolt | 2. Alternator |
|------------------|---------------|

2. Increase or decrease the alternator-belt tension and tighten the bolts.
3. Check the deflection of the belt again to ensure that the tension is correct.

Hydraulic System Maintenance

Hydraulic System Safety

- Seek immediate medical attention if fluid is injected into skin. Injected fluid must be surgically removed within a few hours by a doctor.
- Ensure that all hydraulic-fluid hoses and lines are in good condition and all hydraulic connections and fittings are tight before applying pressure to the hydraulic system.
- Keep your body and hands away from pinhole leaks or nozzles that eject high-pressure hydraulic fluid.
- Use cardboard or paper to find hydraulic leaks.
- Safely relieve all pressure in the hydraulic system before performing any work on the hydraulic system.

Servicing the Hydraulic Fluid

Hydraulic Fluid Specifications

The reservoir is filled at the factory with high-quality hydraulic fluid. Check the level of the hydraulic fluid before you first start the engine and daily thereafter; refer to [Checking the Hydraulic-Fluid Level \(page 64\)](#).

Recommended hydraulic fluid: Toro PX Extended Life Hydraulic Fluid; available in 19 L (5 US gallon) pails or 208 L (55 US gallon) drums.

Note: A machine using the recommended replacement fluid requires less frequent fluid and filter changes.

Alternative hydraulic fluids: If Toro PX Extended Life Hydraulic Fluid is not available, you may use another conventional, petroleum-based hydraulic fluid having specifications that fall within the listed range for all the following material properties and that it meets industry standards. Do not use synthetic fluid. Consult with your lubricant distributor to identify a satisfactory product.

Note: Toro does not assume responsibility for damage caused by improper substitutions, so use products only from reputable manufacturers who will stand behind their recommendation.

High Viscosity Index/Low Pour Point Anti-wear Hydraulic Fluid, ISO VG 46

High Viscosity Index/Low Pour Point Anti-wear Hydraulic Fluid, ISO VG 46 (cont'd.)

Material Properties:

Viscosity, ASTM D445	cSt @ 40°C (104°F) 44 to 48
Viscosity Index ASTM D2270	140 or higher
Pour Point, ASTM D97	-37°C to -45°C (-34°F to -49°F)
Industry Specifications:	Eaton Vickers 694 (I-286-S, M-2950-S/35VQ25 or M-2952-S)

Note: Many hydraulic fluids are almost colorless, making it difficult to spot leaks. A red dye additive for the hydraulic fluid is available in 20 ml (0.67 fl oz) bottles. A bottle is sufficient for 15 to 22 L (4 to 6 US gallons) of hydraulic fluid. Order Part No. 44-2500 from your authorized Toro distributor.

Important: Toro Premium Synthetic Biodegradable Hydraulic Fluid is the only synthetic biodegradable fluid approved by Toro. This fluid is compatible with the elastomers used in Toro hydraulic systems and is suitable for a wide-range of temperature conditions. This fluid is compatible with conventional mineral oils, but for maximum biodegradability and performance, the hydraulic system should be thoroughly flushed of conventional fluid. The oil is available in 19 L (5 US gallons) pails or 208 L (55 US gallons) from your authorized Toro distributor.

Checking the Hydraulic-Fluid Level

Service Interval: Before each use or daily

1. Position the machine on a level surface, lower the cutting decks, and turn the key in the switch to the OFF position.
2. Check the hydraulic-fluid level ([Figure 91](#)).

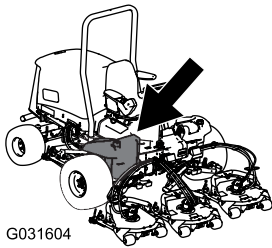

G031604

g031604

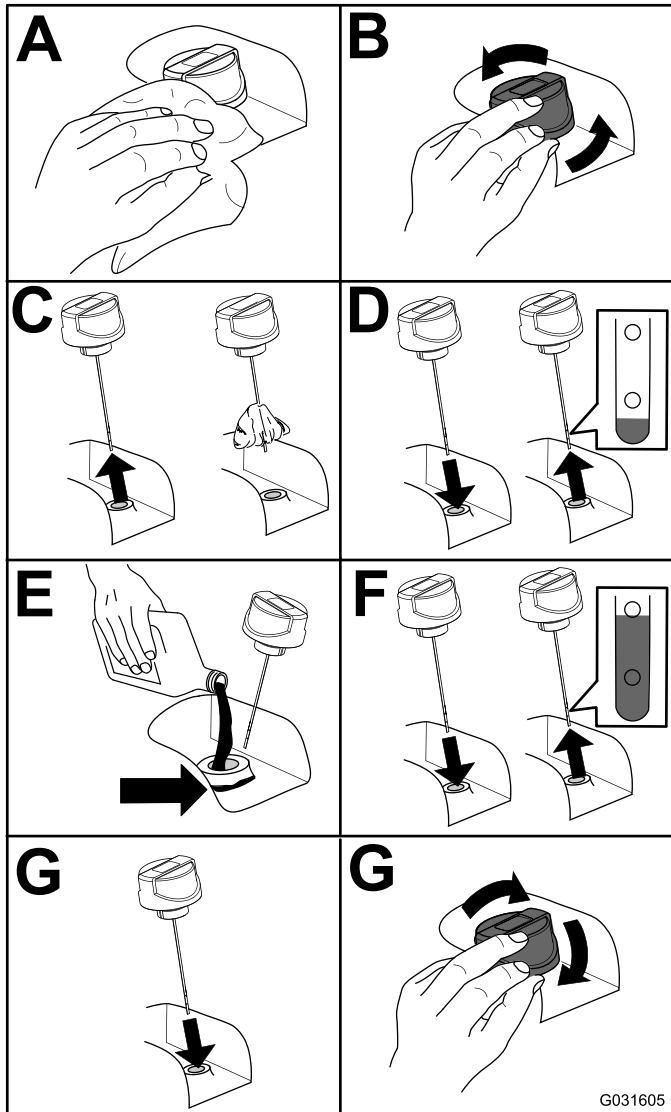

G031605

g031605

Figure 91

Changing the Hydraulic Fluid

Service Interval: Every 2,000 hours—**If you are using the recommended hydraulic fluid**, change the hydraulic fluid.

Every 800 hours—**If you are not using the recommended hydraulic fluid or have ever filled the reservoir with an alternative fluid**, change the hydraulic fluid.

Hydraulic Fluid Capacity: 56.7 L (15 US gallons)

If fluid becomes contaminated, contact your Toro Distributor because the system must be flushed. Contaminated fluid looks milky or black when compared to clean oil.

1. Turn the key in the switch to the OFF position and raise the hood.
2. Place a large drain pan under the fitting secured to the bottom of the hydraulic-fluid reservoir (Figure 92).

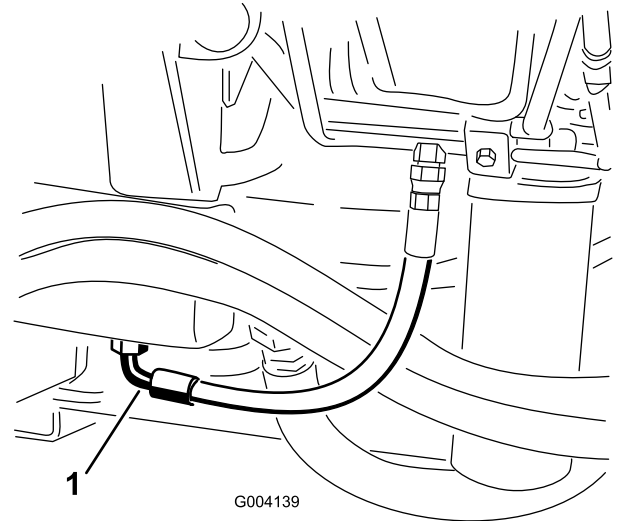

G004139

g004139

Figure 92

1. Hose

3. Disconnect the hose from the bottom of the fitting and let the hydraulic fluid flow into the drain pan.
4. Install the hose when hydraulic fluid stops draining.
5. Fill the reservoir with hydraulic fluid (Figure 91).

Important: Use only hydraulic fluids specified. Other fluids could cause system damage.

6. Install the reservoir cap.
7. Turn the key in the switch to the ON position, start the engine, use all of the hydraulic controls to distribute hydraulic fluid throughout the system, and check for leaks.
8. Turn the key in the switch to the OFF position.
9. Check the level of the hydraulic fluid and add enough to raise level to the Full mark on the dipstick.

Important: Do not overfill.

Replacing the Hydraulic Filters

Service Interval: Every 1,000 hours—**If you are using the recommended hydraulic fluid**, replace the hydraulic filter (sooner if the service interval indicator is in the red zone).

Every 800 hours—**If you are not using the recommended hydraulic fluid or have ever filled the reservoir with an alternative fluid**, replace the hydraulic filter (sooner if the service interval indicator is in the red zone).

The hydraulic system is equipped with a service-interval indicator (Figure 93). With the engine running, view the indicator, it should be in the green zone. When the indicator is in the red zone, change the hydraulic filters.

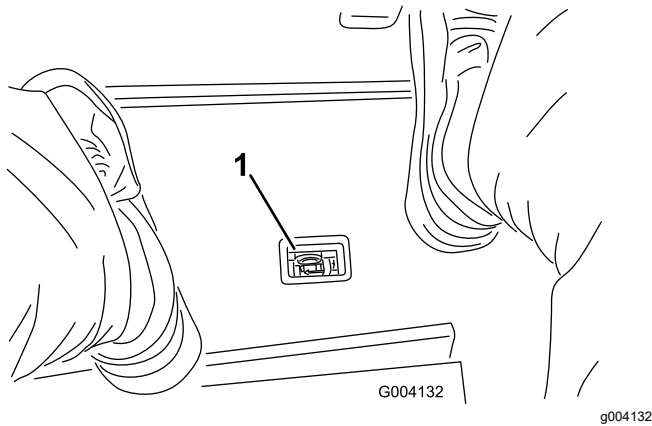

Figure 93

1. Hydraulic-filter restriction indicator

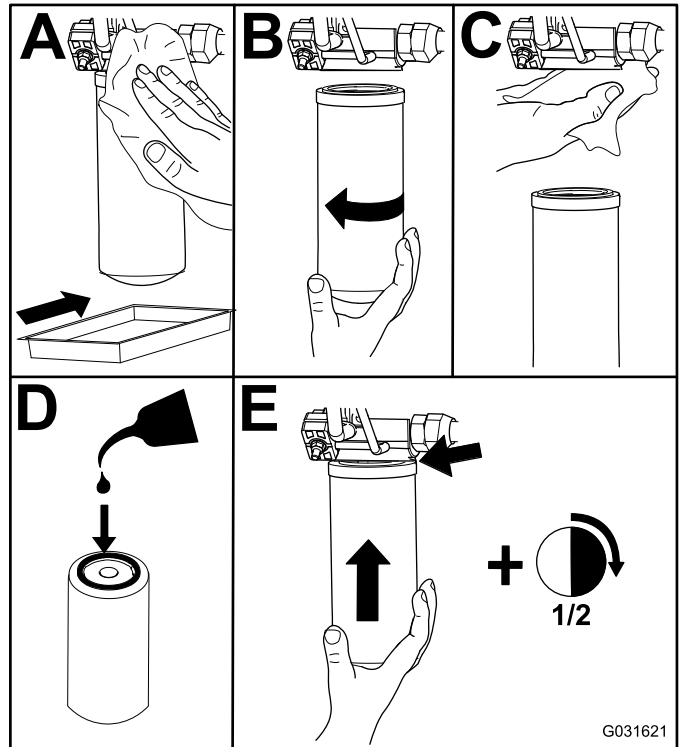
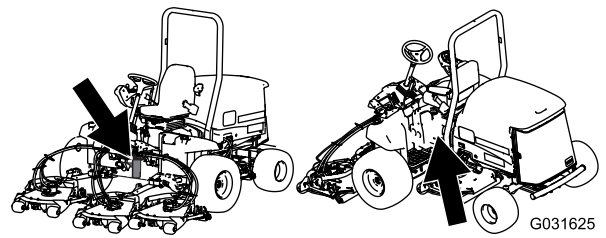

Figure 94

Important: Use of any other filters may void the warranty on some components.

1. Position the machine on a level surface, lower the cutting decks, turn the key in the switch to the OFF position, engage the parking brake, and remove the key.
2. Replace both of the hydraulic filters (Figure 94).

3. Turn the key in the switch to the ON position, start the engine, and let it run for about 2 minutes to purge air from the system.
4. Turn the key in the switch to the OFF position and check for leaks.

Checking the Hydraulic Lines and Hoses

Service Interval: Before each use or daily
Every 2 years—Replace the hydraulic hoses.

Make all necessary repairs before operating.

⚠ WARNING

Hydraulic fluid escaping under pressure can penetrate skin and cause injury.

- Seek immediate medical help if fluid is injected into skin.
- Make sure that all hydraulic-fluid hoses and lines are in good condition and all hydraulic connections and fittings are tight before applying pressure to the hydraulic system.
- Keep your body and hands away from pinhole leaks or nozzles that eject high-pressure hydraulic fluid.
- Use cardboard or paper to find hydraulic leaks.
- Safely relieve all pressure in the hydraulic system before performing any work on the hydraulic system.

Testing the Hydraulic-System Pressure

Use the hydraulic system test ports to test the pressure in the hydraulic circuits. Contact your authorized Toro distributor for assistance.

Hydraulic Valve Solenoid Functions

Use the list below to identify and describe the different functions of the solenoids in the hydraulic manifold. Each solenoid must be energized to allow function to occur.

Solenoid	Function
PRV2	Front mower circuit
PRV1	Rear mower circuit
PRV	Lift/lower cutting decks
S1	Lower cutting decks
S2	Lower cutting decks

Cutting Unit Maintenance

Separating the Cutting Unit from the Traction Unit

1. Position the machine on a level surface, lower the cutting units to the floor, turn the key in the switch to the OFF position, and engage the parking brake.
2. Disconnect and remove the hydraulic motor from the cutting unit (Figure 95). Cover the top of the spindle to prevent contamination.

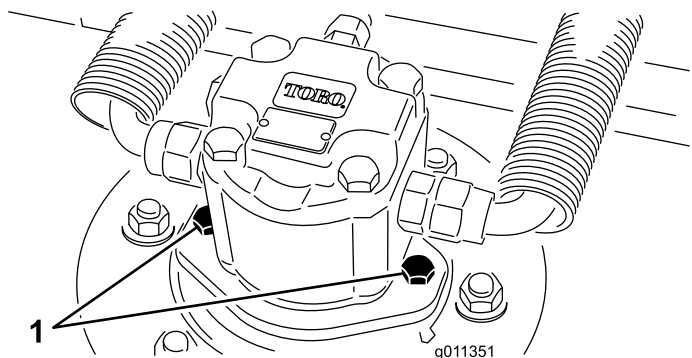

Figure 95

1. Motor-mounting screws

3. Remove the lynch pin securing the deck-carrier frame to the lift-arm pivot pin (Figure 96).

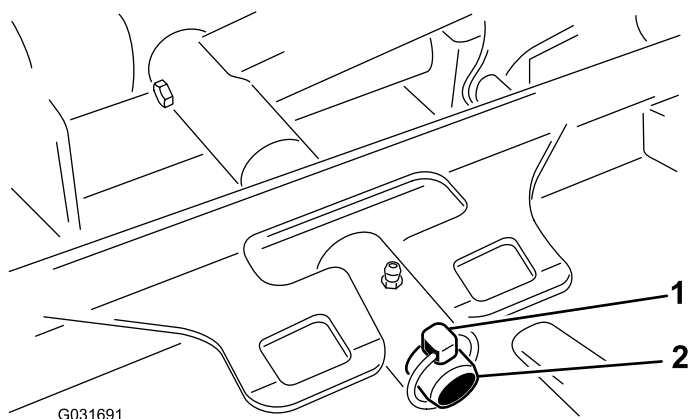

Figure 96

1. Lynch pin
2. Lift-arm pivot pin

4. Roll the cutting unit away from the traction unit.

Mounting the Cutting Units to the Traction Unit

1. Position the machine on a level surface and turn the key in the switch to the OFF position.
2. Move the cutting unit into position in front of the traction unit.
3. Slide the deck-carrier frame onto the lift-arm pivot pin and secure it with the lynch pin (Figure 96).
4. Install the hydraulic motor to the deck (Figure 95). Make sure that the O-ring is in position and not damaged.
5. Grease the spindle.

Servicing the Front Roller

Inspect the front roller for wear, excess wobble, or binding. Service or replace the roller or components if any of these conditions exist.

Disassembling the Front Roller

1. Remove the roller-mounting bolt (Figure 97).
2. Insert a punch through the end of the roller housing and drive the opposite bearing out by alternating taps to the opposite side of inner bearing race. There should be a 1.5 mm (0.060 inch) lip of inner race exposed.

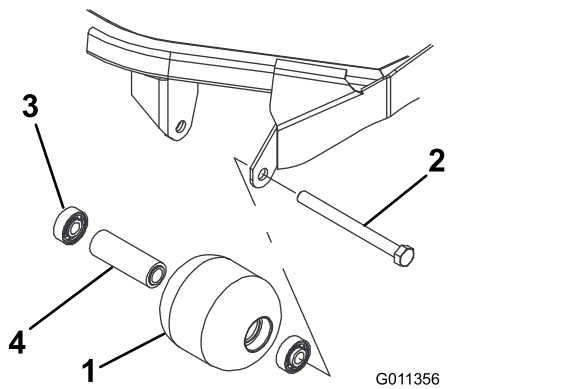

Figure 97

- | | |
|------------------|-------------------|
| 1. Front roller | 3. Bearing |
| 2. Mounting bolt | 4. Bearing spacer |

Assembling the Front Roller

1. Press the first bearing into the roller housing (Figure 97). Press on the outer race only or equally on the inner and outer race.
2. Insert the spacer (Figure 97).
3. Press the second bearing into the roller housing (Figure 97). Pressing equally on the inner and outer race until the inner race contacts the spacer.
4. Install the roller assembly into the cutting-unit frame.
5. Verify that there is no more than a 1.5 mm (0.060 inch) gap between roller assembly and the roller mount brackets of the cutting-unit frame. If there is a gap over 1.5 mm (0.060 inch), install enough 5/8-inch diameter washers to take up the slop.
Important: Securing the roller assembly with a gap larger than 1.5 mm (0.060 inch) creates a side load on the bearing and can lead to premature bearing failure
6. Torque the mounting bolt to 108 N·m (80 ft-lb).

3. Push the second bearing out in press.
4. Inspect the roller housing, bearings, and bearing spacer for damage (Figure 97). Replace any damaged components and assemble them.

Blade Maintenance

Blade Safety

- Inspect the blade periodically for wear or damage.
- Use care when checking the blades. Wrap the blades or wear gloves, and use caution when servicing the blades. Only replace or sharpen the blades; never straighten or weld them.
- On multi-bladed machines, take care as rotating one blade can cause other blades to rotate.

Servicing the Blade Plane

The rotary deck comes from the factory preset at 5 cm (2 inches) height of cut and blade rake of 7.9 mm (0.310 inch). The left and right heights are also preset to within ± 0.7 mm (0.030 inch) of the other.

The cutting deck is designed to withstand blade impacts without deformation of the chamber. If a solid object is struck, inspect the blade for damage and the blade plane for accuracy.

Inspecting the Blade Plane

1. Remove the hydraulic motor from the cutting deck and remove the cutting deck from the tractor.
2. Use a hoist (or minimum of 2 people) and place the cutting deck on a flat table.
3. Mark 1 end of the blade with a paint pen or marker. Use this end of the blade to check all heights.
4. Position the cutting edge of the marked end of the blade at 12 o'clock (straight ahead in the direction of mowing) (Figure 98) and measure height from table to cutting edge of blade.

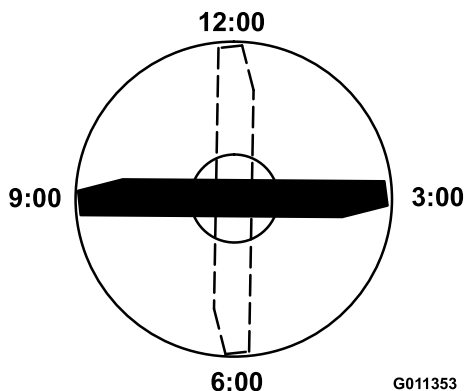

Figure 98

5. Rotate the marked end of the blade to the 3 and 9 o'clock positions (Figure 98) and measure the heights.

6. Compare the 12 o'clock measured height to the height-of-cut setting. It should be within 0.7 mm (0.030 inch). The 3 and 9 o'clock heights should be 1.6 to 6.0 mm (0.06 to 0.24 inch) higher than the 12 o'clock setting and within 1.6 to 6.0 mm (0.06 to 0.24 inch) of each other.

Note: If any of these measurements are not within specification, proceed to [Adjusting the Blade Plane](#) (page 69).

Adjusting the Blade Plane

Start with the front adjustment (change 1 bracket at a time).

1. Remove the height-of-cut bracket (front, left, or right) from the deck frame (Figure 99).
2. Adjust 1.5 mm (0.060 inch) shims and/or 0.7 mm (0.030 inch) shim between the deck frame and bracket to achieve the desired height setting (Figure 99).

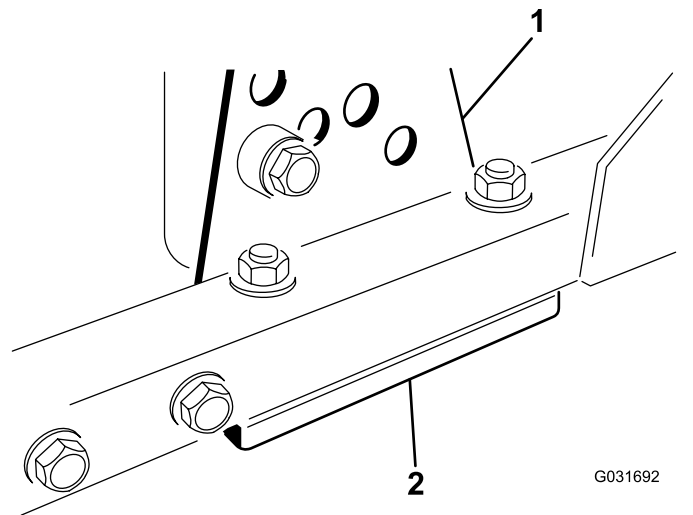

Figure 99

1. Height-of-cut bracket
2. Shims

3. Install the height-of-cut bracket to the deck frame with the remaining shims assembled below the height-of-cut bracket.
4. Secure the socket-head bolt/spacer and flange nut.

Note: Socket-head bolt/spacer are held together with thread-locking adhesive to prevent the spacer from falling inside the deck frame.

5. Verify the 12 o'clock height and adjust if needed.
6. Determine if only 1 or both (right and left) height-of-cut brackets need to be adjusted. If the 3 or 9 o'clock side is 1.6 to 6.0 mm (0.06 to 0.24 inch) higher than the new front height then no adjustment is needed for that side. Adjust the

other side to within 1.6 to 6.0 mm (0.06 to 0.24 inch) of the correct side.

- Adjust the right and/or left height-of-cut brackets by repeating steps 1 through 3.
- Secure the carriage bolts and flange nuts.
- Again, verify the 12, 3, and 9 o'clock heights.

Removing and Installing the Cutting-Unit Blade(s)

Replace the blade if it hits a solid object, is out of balance, or is bent. Always use genuine Toro replacement blades to ensure safety and optimum performance.

- Park the machine on a level surface, raise the cutting unit to the transport position, engage the parking brake, shut off the engine, and remove the key.

Note: Block or lock the cutting unit to prevent it from accidentally falling.

- Grasp the end of the blade using a rag or thickly-padded glove.
- Remove the blade bolt, anti-scalp cup, and blade from the spindle shaft (Figure 100).

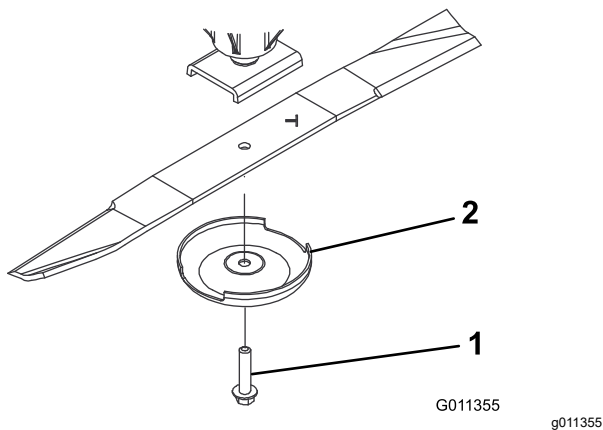

Figure 100

- Blade bolt
- Anti-scalp cup

- Install the blade, anti-scalp cup, and blade bolt and tighten the blade bolt to 115 to 149 N·m (85 to 110 ft-lb).

Important: The curved part of the blade must be pointing toward the inside of the cutting unit to ensure proper cutting.

Note: 7

After striking a foreign object, torque all spindle-pulley nuts to 115 to 149 N·m (85 to 110 ft-lb).

Inspecting and Sharpening the Blade

- Raise the cutting deck to the transport position, turn the key in the ignition switch to the OFF position, and engage the parking brake.
- Block the cutting deck to prevent it from falling accidentally.
- Examine the cutting ends of the blade carefully, especially where the flat and curved parts of the blade meet (Figure 101).

Note: Since sand and abrasive material can wear away the metal that connects the flat and curved parts of the blade, check the blade before using the machine.

- If wear is noticed (Figure 101), replace the blade; refer to [Servicing the Blade Plane](#) (page 69).

⚠ DANGER

If the blade is allowed to wear, a slot will form between the sail and flat part of the blade (Figure 101). Eventually a piece of the blade may break off and be thrown from under the housing, possibly resulting in serious injury to yourself or bystanders.

- Inspect the blade periodically for wear or damage.
- Always replace a worn or damaged blade.

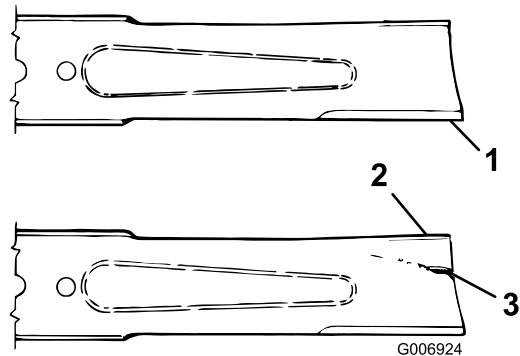

Figure 101

- Cutting edge
- Sail
- Wear/slot/crack

- Inspect the cutting edges of all blades. Sharpen the cutting edges if they are dull or nicked. Sharpen only the top of the cutting edge and maintain the original cutting angle to make sure that it is sharp (Figure 102).

- If dull or nicked, sharpen only the top cutting edge while maintaining the original cutting angle (Figure 102).

Note: The blade will remain balanced if the same amount of metal is removed from both cutting edges.

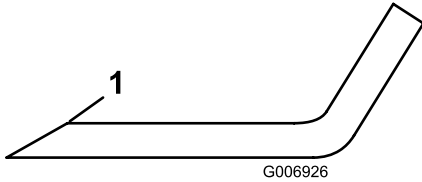

Figure 102

- Sharpen at this angle only

- To check the blade for being straight and parallel, lay the blade on a level surface and check its ends.

Note: Position the ends of the blade slightly lower than the center, and the cutting edge lower than the heel of the blade. This blade produces a good quality of cut and requires minimal power from the engine. By contrast a blade that is higher at the ends than the center, or if cutting edge is higher than the heel, the blade is bent or warped and must be replaced.

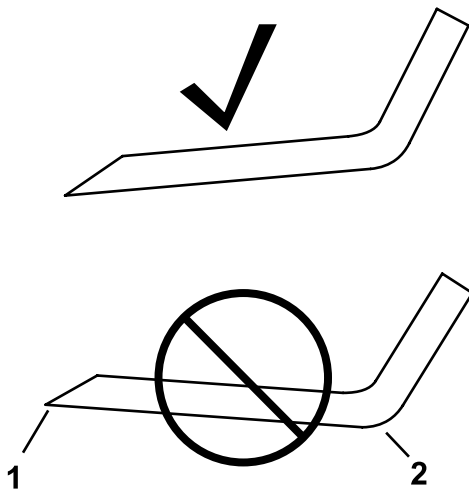

Figure 103

- Cutting edge
- Heel

- Install the blade, sail facing toward cutting deck, with the anti-scalp cup and blade bolt. Torque the blade bolt to 115 to 149 N·m (85 to 110 ft-lb).

Storage

Storage Safety

- Shut off the engine, remove the key, and wait for all movement to stop before you leave the operator's position. Allow the machine to cool before adjusting, servicing, cleaning, or storing it.
- Do not store the machine or fuel container where there is an open flame, spark, or pilot light, such as on a water heater or other appliance.

Preparing the Machine for Storage

Important: Do not use brackish or reclaimed water to clean the machine.

Preparing the Traction Unit

- Thoroughly clean the traction unit, cutting units, and engine.
- Check the tire pressure. Inflate all traction unit tires to 83 to 103 kPa (12 to 15 psi).
- Check all fasteners for looseness and tighten them as necessary.
- Grease all grease fittings and pivot points. Wipe up any excess lubricant.
- Lightly sand and use touch-up paint on painted areas that are scratched, chipped, or rusted. Repair any dents in the metal body.
- Service the battery and cables as follows:
 - Remove the battery terminals from the battery posts.

Note: Always disconnect the negative terminal first and the positive last. Always connect the positive terminal first and the negative last.
 - Clean the battery, terminals, and posts with a wire brush and baking soda solution.
 - Coat the cable terminals and battery posts with Grafo 112X skin-over grease (Part Number 505-47) or petroleum jelly to prevent corrosion.
 - Slowly recharge the battery every 60 days for 24 hours to prevent lead sulfation of the battery.

Preparing the Engine

1. Drain the engine oil from the oil pan and replace the drain plug.
2. Remove and discard the oil filter. Install a new oil filter.
3. Refill the oil pan with designated quantity of motor oil.
4. Turn the key in the switch to the ON position, start the engine, and run it at idle speed for approximately 2 minutes.
5. Turn the key in the switch to the OFF position.
6. Thoroughly drain all fuel from the fuel tank, lines, and the fuel filter/water separator assembly.
7. Flush the fuel tank with fresh, clean diesel fuel.
8. Secure all fuel-system fittings.
9. Thoroughly clean and service the air-cleaner assembly.
10. Seal the air-cleaner inlet and the exhaust outlet with weatherproof tape.
11. Check the antifreeze protection and add as needed for expected minimum temperature in your area.

Storing the Cutting Units

If a cutting unit is separated from the traction unit for any length of time, install a spindle plug in the top of the spindle to protect the spindle from dust and water.

Notes:

European Privacy Notice

The Information Toro Collects

Toro Warranty Company (Toro) respects your privacy. In order to process your warranty claim and contact you in the event of a product recall, we ask you to share certain personal information with us, either directly or through your local Toro company or dealer.

The Toro warranty system is hosted on servers located within the United States where privacy law may not provide the same protection as applies in your country.

BY SHARING YOUR PERSONAL INFORMATION WITH US, YOU ARE CONSENTING TO THE PROCESSING OF YOUR PERSONAL INFORMATION AS DESCRIBED IN THIS PRIVACY NOTICE.

The Way Toro Uses Information

Toro may use your personal information to process warranty claims, to contact you in the event of a product recall and for any other purpose which we tell you about. Toro may share your information with Toro's affiliates, dealers or other business partners in connection with any of these activities. We will not sell your personal information to any other company. We reserve the right to disclose personal information in order to comply with applicable laws and with requests by the appropriate authorities, to operate our systems properly or for our own protection or that of other users.

Retention of your Personal Information

We will keep your personal information as long as we need it for the purposes for which it was originally collected or for other legitimate purposes (such as regulatory compliance), or as required by applicable law.

Toro's Commitment to Security of Your Personal Information

We take reasonable precautions in order to protect the security of your personal information. We also take steps to maintain the accuracy and current status of personal information.

Access and Correction of your Personal Information

If you would like to review or correct your personal information, please contact us by email at legal@toro.com.

Australian Consumer Law

Australian customers will find details relating to the Australian Consumer Law either inside the box or at your local Toro Dealer.

California Proposition 65 Warning Information

What is this warning?

You may see a product for sale that has a warning label like the following:



WARNING: Cancer and Reproductive Harm—www.p65Warnings.ca.gov.

What is Prop 65?

Prop 65 applies to any company operating in California, selling products in California, or manufacturing products that may be sold in or brought into California. It mandates that the Governor of California maintain and publish a list of chemicals known to cause cancer, birth defects, and/or other reproductive harm. The list, which is updated annually, includes hundreds of chemicals found in many everyday items. The purpose of Prop 65 is to inform the public about exposure to these chemicals.

Prop 65 does not ban the sale of products containing these chemicals but instead requires warnings on any product, product packaging, or literature with the product. Moreover, a Prop 65 warning does not mean that a product is in violation of any product safety standards or requirements. In fact, the California government has clarified that a Prop 65 warning "is not the same as a regulatory decision that a product is 'safe' or 'unsafe.'" Many of these chemicals have been used in everyday products for years without documented harm. For more information, go to <https://oag.ca.gov/prop65/faqs-view-all>.

A Prop 65 warning means that a company has either (1) evaluated the exposure and has concluded that it exceeds the "no significant risk level"; or (2) has chosen to provide a warning based on its understanding about the presence of a listed chemical without attempting to evaluate the exposure.

Does this law apply everywhere?

Prop 65 warnings are required under California law only. These warnings are seen throughout California in a wide range of settings, including but not limited to restaurants, grocery stores, hotels, schools, and hospitals, and on a wide variety of products. Additionally, some online and mail order retailers provide Prop 65 warnings on their websites or in catalogs.

How do the California warnings compare to federal limits?

Prop 65 standards are often more stringent than federal and international standards. There are various substances that require a Prop 65 warning at levels that are far lower than federal action limits. For example, the Prop 65 standard for warnings for lead is 0.5 µg/day, which is well below the federal and international standards.

Why don't all similar products carry the warning?

- Products sold in California require Prop 65 labelling while similar products sold elsewhere do not.
- A company involved in a Prop 65 lawsuit reaching a settlement may be required to use Prop 65 warnings for its products, but other companies making similar products may have no such requirement.
- The enforcement of Prop 65 is inconsistent.
- Companies may elect not to provide warnings because they conclude that they are not required to do so under Prop 65; a lack of warnings for a product does not mean that the product is free of listed chemicals at similar levels.

Why does Toro include this warning?

Toro has chosen to provide consumers with as much information as possible so that they can make informed decisions about the products they buy and use. Toro provides warnings in certain cases based on its knowledge of the presence of one or more listed chemicals without evaluating the level of exposure, as not all the listed chemicals provide exposure limit requirements. While the exposure from Toro products may be negligible or well within the "no significant risk" range, out of an abundance of caution, Toro has elected to provide the Prop 65 warnings. Moreover, if Toro does not provide these warnings, it could be sued by the State of California or by private parties seeking to enforce Prop 65 and subject to substantial penalties.



The Toro Warranty

Two-Year or 1,500 Hours Limited Warranty

Conditions and Products Covered

The Toro Company warrants your Toro Commercial product ("Product") to be free from defects in materials or workmanship for 2 years or 1,500 operational hours*, whichever occurs first. This warranty is applicable to all products with the exception of Aerators (refer to separate warranty statements for these products). Where a warrantable condition exists, we will repair the Product at no cost to you including diagnostics, labor, parts, and transportation. This warranty begins on the date the Product is delivered to the original retail purchaser.

* Product equipped with an hour meter.

Instructions for Obtaining Warranty Service

You are responsible for notifying the Commercial Products Distributor or Authorized Commercial Products Dealer from whom you purchased the Product as soon as you believe a warrantable condition exists. If you need help locating a Commercial Products Distributor or Authorized Dealer, or if you have questions regarding your warranty rights or responsibilities, you may contact us at:

Toro Commercial Products Service Department
8111 Lyndale Avenue South
Bloomington, MN 55420-1196

952-888-8801 or 800-952-2740
E-mail: commercial.warranty@toro.com

Owner Responsibilities

As the product owner, you are responsible for required maintenance and adjustments stated in your *Operator's Manual*. Repairs for product issues caused by failure to perform required maintenance and adjustments are not covered under this warranty.

Items and Conditions Not Covered

Not all product failures or malfunctions that occur during the warranty period are defects in materials or workmanship. This warranty does not cover the following:

- Product failures which result from the use of non-Toro replacement parts, or from installation and use of add-on, or modified non-Toro branded accessories and products.
- Product failures which result from failure to perform recommended maintenance and/or adjustments.
- Product failures which result from operating the Product in an abusive, negligent, or reckless manner.
- Parts consumed through use that are not defective. Examples of parts which are consumed, or used up, during normal Product operation include, but are not limited to, brake pads and linings, clutch linings, blades, reels, rollers and bearings (sealed or greasable), bed knives, spark plugs, castor wheels and bearings, tires, filters, belts, and certain sprayer components such as diaphragms, nozzles, flow meters, and check valves.
- Failures caused by outside influence, including, but not limited to, weather, storage practices, contamination, use of unapproved fuels, coolants, lubricants, additives, fertilizers, water, or chemicals.
- Failure or performance issues due to the use of fuels (e.g. gasoline, diesel, or biodiesel) that do not conform to their respective industry standards.
- Normal noise, vibration, wear and tear, and deterioration. Normal "wear and tear" includes, but is not limited to, damage to seats due to wear or abrasion, worn painted surfaces, scratched decals or windows.

Countries Other than the United States or Canada

Customers who have purchased Toro products exported from the United States or Canada should contact their Toro Distributor (Dealer) to obtain guarantee policies for your country, province, or state. If for any reason you are dissatisfied with your Distributor's service or have difficulty obtaining guarantee information, contact your Authorized Toro Service Center.

Parts

Parts scheduled for replacement as required maintenance are warranted for the period of time up to the scheduled replacement time for that part. Parts replaced under this warranty are covered for the duration of the original product warranty and become the property of Toro. Toro will make the final decision whether to repair any existing part or assembly or replace it. Toro may use remanufactured parts for warranty repairs.

Deep Cycle and Lithium-Ion Battery Warranty

Deep cycle and Lithium-Ion batteries have a specified total number of kilowatt-hours they can deliver during their lifetime. Operating, recharging, and maintenance techniques can extend or reduce total battery life. As the batteries in this product are consumed, the amount of useful work between charging intervals will slowly decrease until the battery is completely worn out. Replacement of worn out batteries, due to normal consumption, is the responsibility of the product owner. Note: (Lithium-Ion battery only): Refer to the battery warranty for additional information.

Lifetime Crankshaft Warranty (ProStripe 02657 Model Only)

The ProStripe which is fitted with a genuine Toro Friction Disc and Crank-Safe Blade Brake Clutch (integrated Blade Brake Clutch (BBC) + Friction Disc assembly) as original equipment and used by the original purchaser in accordance with recommended operating and maintenance procedures, are covered by a Lifetime Warranty against engine crankshaft bending. Machines fitted with friction washers, Blade Brake Clutch (BBC) units and other such devices are not covered by the Lifetime Crankshaft Warranty.

Maintenance is at Owner's Expense

Engine tune-up, lubrication, cleaning and polishing, replacement of filters, coolant, and completing recommended maintenance are some of the normal services Toro products require that are at the owner's expense.

General Conditions

Repair by an Authorized Toro Distributor or Dealer is your sole remedy under this warranty.

The Toro Company is not liable for indirect, incidental or consequential damages in connection with the use of the Toro Products covered by this warranty, including any cost or expense of providing substitute equipment or service during reasonable periods of malfunction or non-use pending completion of repairs under this warranty. Except for the Emissions warranty referenced below, if applicable, there is no other express warranty. All implied warranties of merchantability and fitness for use are limited to the duration of this express warranty.

Some states do not allow exclusions of incidental or consequential damages, or limitations on how long an implied warranty lasts, so the above exclusions and limitations may not apply to you. This warranty gives you specific legal rights, and you may also have other rights which vary from state to state.

Note Regarding Emissions Warranty

The Emissions Control System on your Product may be covered by a separate warranty meeting requirements established by the U.S. Environmental Protection Agency (EPA) and/or the California Air Resources Board (CARB). The hour limitations set forth above do not apply to the Emissions Control System Warranty. Refer to the Engine Emission Control Warranty Statement supplied with your product or contained in the engine manufacturer's documentation.