



Count on it.

Operator's Manual

**Groundsmaster® 360 4-Wheel
Drive Multi-Purpose Machine**

Model No. 31200—Serial No. 408000000 and Up

Model No. 31202—Serial No. 408000000 and Up



This product complies with all relevant European directives; for details please see the separate product specific Declaration of Conformity (DOC) sheet.

It is a violation of California Public Resource Code Section 4442 or 4443 to use or operate the engine on any forest-covered, brush-covered, or grass-covered land unless the engine is equipped with a spark arrester, as defined in Section 4442, maintained in effective working order or the engine is constructed, equipped, and maintained for the prevention of fire.

The enclosed engine owner's manual is supplied for information regarding the US Environmental Protection Agency (EPA) and the California Emission Control Regulation of emission systems, maintenance, and warranty. Replacements may be ordered through the engine manufacturer.

This engine is not equipped with a spark arrester muffler. It is a violation of California Public Resource Code Section 4442 to operate the engine on any forest-covered, brush-covered, or grass-covered land. Other states or federal areas may have similar laws.

⚠ WARNING

**CALIFORNIA
Proposition 65 Warning**

Diesel engine exhaust and some of its constituents are known to the State of California to cause cancer, birth defects, and other reproductive harm.

Battery posts, terminals, and related accessories contain lead and lead compounds, chemicals known to the State of California to cause cancer and reproductive harm. Wash hands after handling.

Use of this product may cause exposure to chemicals known to the State of California to cause cancer, birth defects, or other reproductive harm.

Introduction

This machine is a ride-on, multi-purpose machine intended to be used by professional, hired operators in commercial applications. It is primarily designed for maintaining grass on well-maintained lawns in parks, sports fields, and on commercial grounds. It is not designed for cutting brush. Using this product

for purposes other than its intended use could prove dangerous to you and bystanders.

Read this information carefully to learn how to operate and maintain your product properly and to avoid injury and product damage. You are responsible for operating the product properly and safely.

Visit www.Toro.com for product safety and operation training materials, accessory information, help finding a dealer, or to register your product.

Whenever you need service, genuine Toro parts, or additional information, contact an Authorized Service Dealer or Toro Customer Service and have the model and serial numbers of your product ready. **Figure 1** identifies the location of the model and serial numbers on the product. Write the numbers in the space provided.

Important: With your mobile device, you can scan the QR code on the serial number decal (if equipped) to access warranty, parts, and other product information.

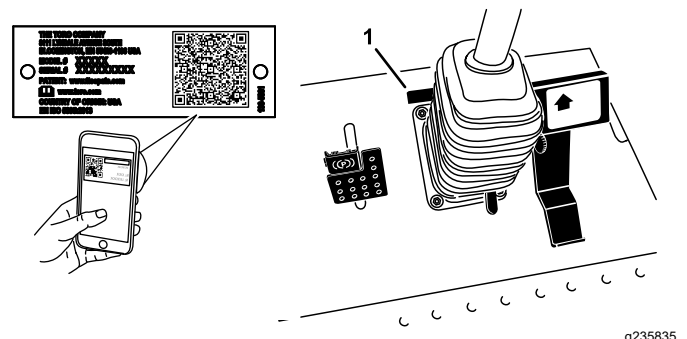

Figure 1

1. Model and serial number location

Model No. _____

Serial No. _____

This manual identifies potential hazards and has safety messages identified by the safety-alert symbol (**Figure 2**), which signals a hazard that may cause serious injury or death if you do not follow the recommended precautions.



Figure 2

Safety-alert symbol

This manual also uses 2 words to highlight information. **Important** calls attention to special mechanical

information and **Note** emphasizes general information worthy of special attention.

Contents

Safety	4	Daily Maintenance Checklist.....	48
General Safety	4	Pre-Maintenance Procedures	49
Safety and Instructional Decals	4	Using the Hood-Prop Rod	49
Setup	11	Lubrication	50
1 Installing the PTO Driveshaft to an Optional		Greasing the Bearings and Bushings	50
Cutting Unit or QAS.....	11	Engine Maintenance	52
2 Using the Optional Cutting-Unit-Mounting		Engine Safety	52
Hardware	12	Servicing the Air Cleaner	52
3 Adjusting the Roll Bar.....	12	Servicing the Engine Oil.....	53
4 Checking the Tire Pressure.....	13	Servicing the Diesel-Oxidation Catalyst	
5 Checking the Fluid Levels	13	(DOC) and the Soot Filter	54
6 Installing the Decal (CE Machines		Fuel System Maintenance	55
Only)	13	Servicing the Water Separator	55
Product Overview	14	Servicing the Engine Fuel Filter	56
Controls	14	Draining the Fuel Tank.....	56
Cab Controls	15	Inspecting the Fuel Lines and	
Specifications	17	Connections.....	56
Attachments/Accessories	18	Cleaning the Fuel Pick-Up Tube Screen.....	56
Before Operation	18	Electrical System Maintenance	57
Before Operation Safety	18	Electrical System Safety	57
Adding Fuel	19	Servicing the Battery.....	57
Checking the Engine-Oil Level.....	20	Checking the Fuses	57
Checking the Cooling System	20	Storing the Battery	58
Checking the Hydraulic System	20	Drive System Maintenance	58
The Safety-Interlock System.....	20	Checking the Tire Pressure.....	58
Positioning the Standard Seat	21	Correcting the Steering Misalignment.....	58
Raising and Lowering the Seat	21	Cooling System Maintenance	59
Adjusting the Height of Cut	22	Cooling System Safety	59
Using the InfoCenter LCD Display	22	Coolant Specification.....	59
Using the Menus.....	24	Checking the Cooling System	60
Protected Menus	25	Cleaning the Radiator	60
Accessing Protected Menus	25	Brake Maintenance	61
During Operation	26	Adjusting the Brakes.....	61
During Operation Safety	26	Adjusting the Parking Brake	61
Starting the Engine	28	Belt Maintenance	62
Shutting Off the Engine.....	29	Checking the Alternator Belt	62
Driving the Machine	29	Controls System Maintenance	62
Stopping the Machine	29	Adjusting the Traction Drive for Neutral	62
Selecting the Steering Mode	29	Adjusting the Maximum Ground Speed.....	63
Operating the Cutting Unit or		Hydraulic System Maintenance	64
Attachment.....	30	Hydraulic System Safety.....	64
Cutting Grass with the Machine	31	Hydraulic Fluid Specification.....	64
Diesel Particulate Filter Regeneration.....	32	Checking the Hydraulic System	64
Operating Tips	44	Changing the Hydraulic Fluid And	
After Operation	44	Filter.....	64
General Safety	44	Cab Maintenance	65
Pushing the Machine by Hand	44	Filling the Washer-Fluid Bottle	65
Hauling the Machine	45	Cleaning the Cab Air Filters	66
Locating the Tie-Down Points	45	Cleaning the Air-Conditioning Coil	66
Maintenance	46	Cleaning	67
Maintenance Safety.....	46	Cleaning the Cab.....	67
Recommended Maintenance Schedule(s)	46	Waste Disposal.....	67
		Storage	68
		Storage Safety.....	68
		Preparing the Machine.....	68
		Preparing the Engine	68

Safety

This machine has been designed in accordance with CEN standard ANSI B71.4-2017 and ISO EN 5395 when you install the proper CE Kits and complete the setup procedures.

General Safety

This product is capable of amputating hands and feet and of throwing objects. Always follow all safety instructions to avoid serious personal injury.

- Read and understand the contents of this *Operator's Manual* before starting the engine.
- Use your full attention while operating the machine. Do not engage in any activity that causes distractions; otherwise, injury or property damage may occur.

- Do not operate the machine without all guards and other safety protective devices in place and functioning properly on the machine.
- Keep your hands and feet away from rotating parts. Keep clear of the discharge opening.
- Keep bystanders and children out of the operating area. Never allow children to operate the machine.
- Shut off the engine, remove the key, and wait for all movement to stop before you leave the operator's position. Allow the machine to cool before adjusting, servicing, cleaning, or storing it.

Improperly using or maintaining this machine can result in injury. To reduce the potential for injury, comply with these safety instructions and always pay attention to the safety-alert symbol **▲**, which means Caution, Warning, or Danger—personal safety instruction. Failure to comply with these instructions may result in personal injury or death.

Safety and Instructional Decals



Safety decals and instructions are easily visible to the operator and are located near any area of potential danger. Replace any decal that is damaged or missing.



117-3276

decal117-3276

- | | |
|---|--|
| 1. Engine coolant under pressure | 3. Warning—do not touch the hot surface. |
| 2. Explosion hazard—read the <i>Operator's Manual</i> . | 4. Warning—read the <i>Operator's Manual</i> . |

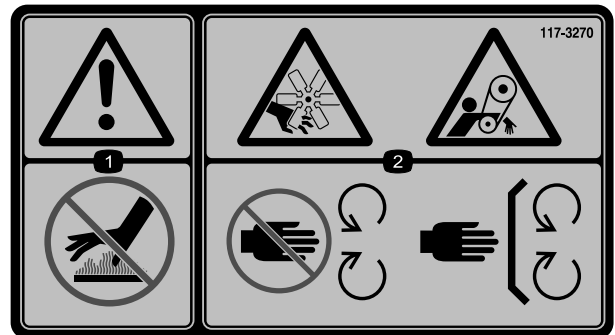

117-3270

decal117-3270

1. Warning—do not touch the hot surface.
2. Cutting/dismemberment hazard, hand; entanglement hazard, belt—stay away from moving parts; keep all guards and shields in place.

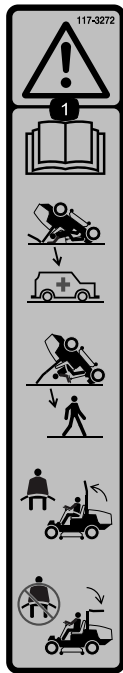

117-3272

decal117-3272

1. Warning—read the *Operator's Manual*; failure to use the rollover protection system (ROPS) can result in injury in the event of a rollover; wear a seat belt when a roll bar is in place, do not wear a seat belt when the roll bar is lowered.

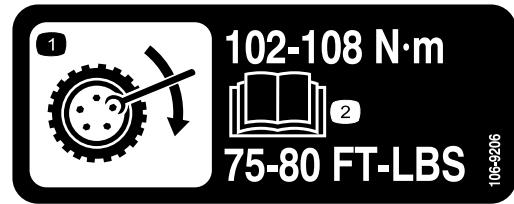

106-9206

decal106-9206

1. Wheel torque specifications
2. Read the *Operator's Manual*.

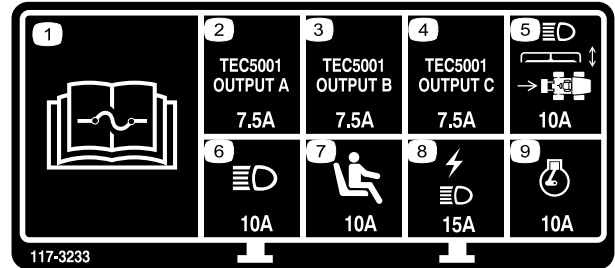

117-3233

decal117-3233

1. Read the *Operator's Manual* for information on fuses.
2. 4-wheel steer solenoid (7.5 A)
3. PTO enable, 4-wheel-steer lamp, deck lift, deck float (7.5 A)
4. Glow indicator, fuel-run solenoid, diagnostic light, start (7.5 A)
5. Headlights, deck actuator, power takeoff (10 A)
6. Lights (10 A)
7. Operator-presence switch (10 A)
8. Power point, lights (15 A)
9. Engine (10 A)

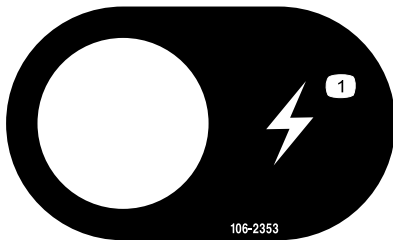

106-2353

decal106-2353

1. Electrical power point

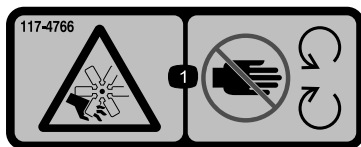

117-4766

decal117-4766

1. Cutting/dismemberment hazard; fan—stay away from moving parts; keep all guards and shields in place.



Battery Symbols

Some or all of these symbols are on your battery.

- | | |
|--|---|
| 1. Explosion hazard | 6. Keep bystanders away from the battery. |
| 2. No fire, open flame, or smoking | 7. Wear eye protection; explosive gases can cause blindness and other injuries. |
| 3. Caustic liquid/chemical burn hazard | 8. Battery acid can cause blindness or severe burns. |
| 4. Wear eye protection. | 9. Flush eyes immediately with water and get medical help fast. |
| 5. Read the <i>Operator's Manual</i> . | 10. Contains lead; do not discard |

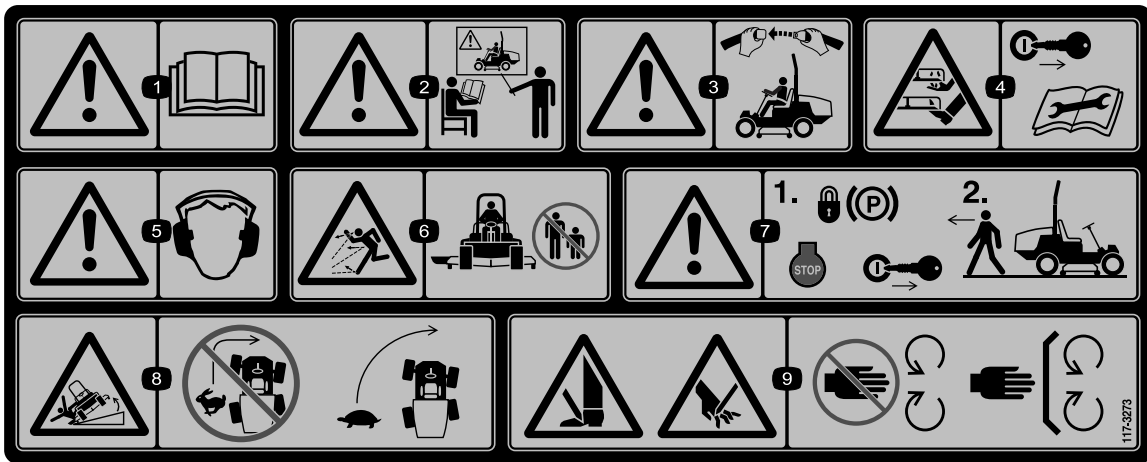

117-3273

decal117-3273

- | | |
|--|--|
| 1. Warning—read the <i>Operator's Manual</i> . | 6. Thrown object hazard—keep bystanders away. |
| 2. Warning—do not operate this machine unless you are trained. | 7. Warning—engage the parking brake, shut off the engine, and remove the key before leaving the machine. |
| 3. Warning—wear the seatbelt when seated in the operator's position. | 8. Tipping hazard—slow the machine before turning; do not turn at high speeds. |
| 4. Cutting/dismemberment hazard of hand or foot, mower blade—remove the key and read the <i>Operator's Manual</i> before performing maintenance. | 9. Cutting hazard of the hand or foot—stay away from moving parts; keep all guards in place. |
| 5. Warning—wear hearing protection. | |

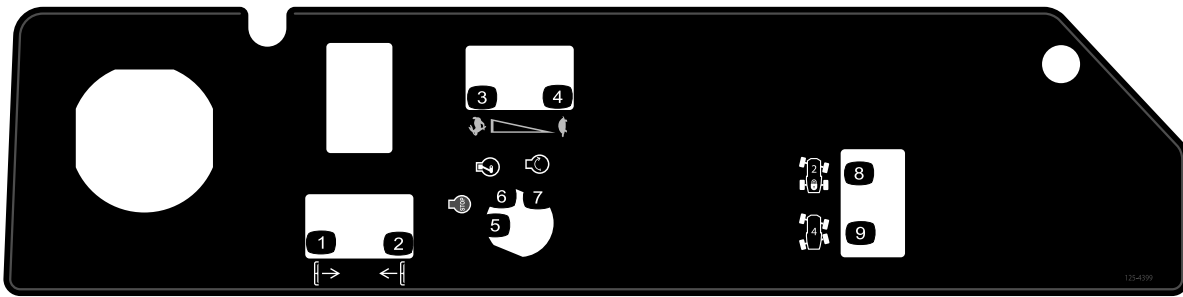

decal125-4399

125-4399

- | | | |
|-------------------|--------------------|---------------------|
| 1. Lower the deck | 4. Slow | 7. Engine—start |
| 2. Raise the deck | 5. Engine—shut off | 8. 2-wheel steering |
| 3. Fast | 6. Engine—run | 9. 4-wheel steering |

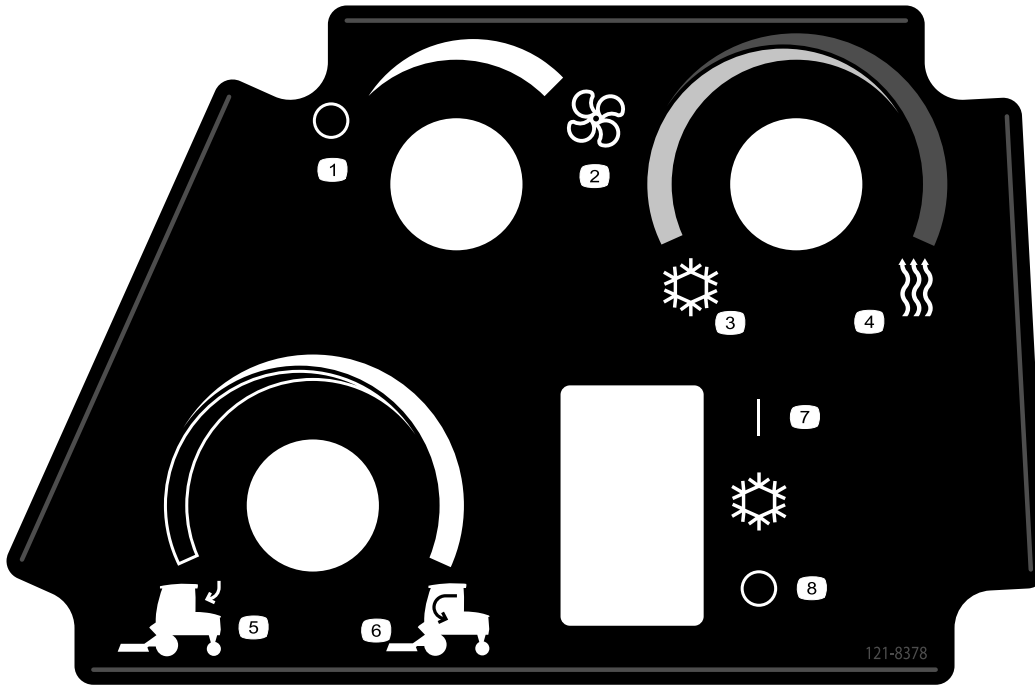

decal121-8378

121-8378

Model with Cab Only

- | | |
|----------------|------------------------|
| 1. Fan—off | 5. External air |
| 2. Fan—on full | 6. Internal air |
| 3. Cold air | 7. Air conditioner—off |
| 4. Hot air | 8. Air conditioner—on |

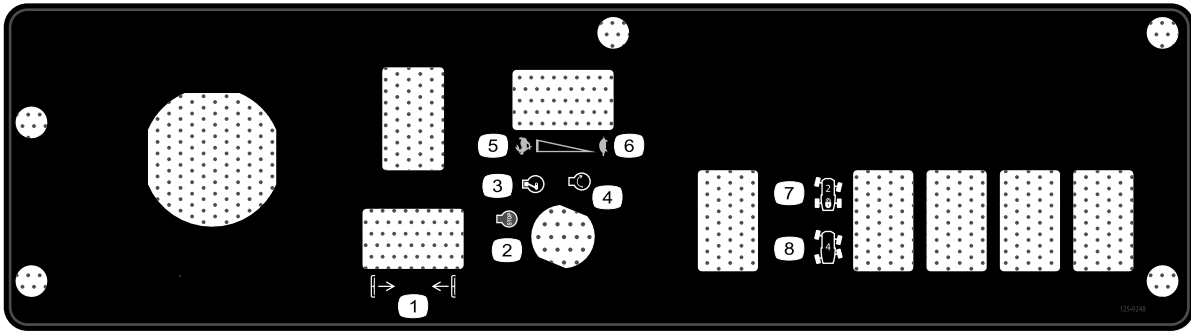

decal125-9248

125-9248

Model with Cab Only

- | | |
|----------------------|---------------------|
| 1. Raise/Lower decks | 5. Fast |
| 2. Engine—stop | 6. Slow |
| 3. Engine—run | 7. 2-wheel steering |
| 4. Engine—start | 8. 4-wheel steering |

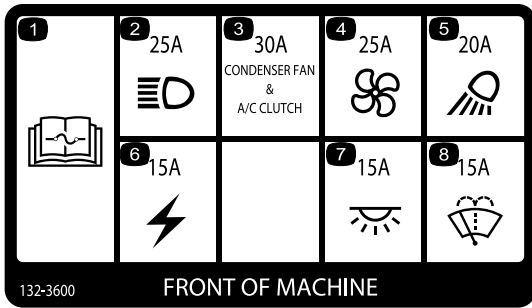

132-3600

FRONT OF MACHINE

decal132-3600

132-3600

Model with Cab Only

- | | |
|---|-----------------------------|
| 1. Read the <i>Operator's Manual</i> for more information on fuses. | 5. Working light (20 A) |
| 2. Headlight (25 A) | 6. Auxiliary power (15 A) |
| 3. Condenser fan and A/C clutch (30 A) | 7. Cab light (15 A) |
| 4. Fan (25 A) | 8. Windshield wipers (15 A) |

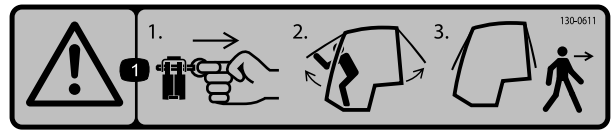

decal130-0611

130-0611

Model with Cab Only

1. Warning—1) Remove the pin; 2) Raise the doors; 3) Exit the cab

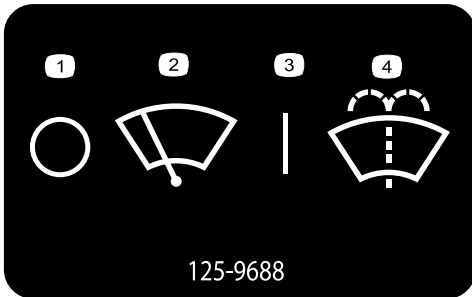

125-9688

decal125-9688

125-9688

Model with Cab Only

- | | |
|--------------------------|----------------------------------|
| 1. Windshield wipers—off | 3. Windshield wipers—on |
| 2. Windshield wipers | 4. Spray windshield washer fluid |



130-0594

Model with Cab Only

decal130-0594

1. Warning—read the *Operator's Manual*; when sitting in the cab, always wear a seat belt; wear hearing protection.

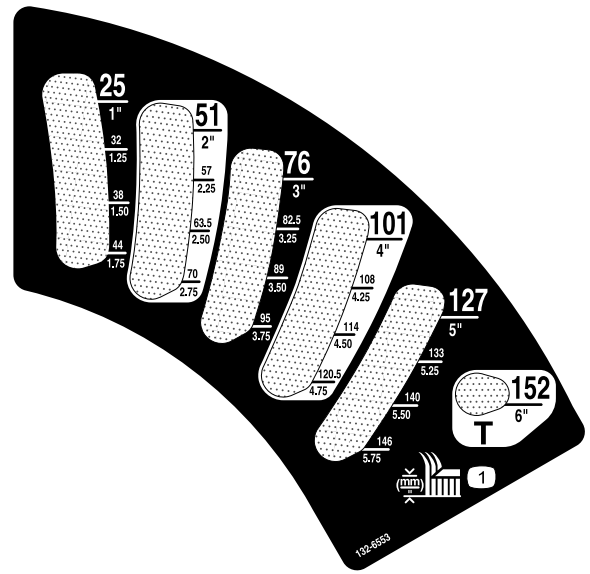

132-6553

Model with Cab Only

decal132-6553

1. Height of cut



133-8062

decal133-8062

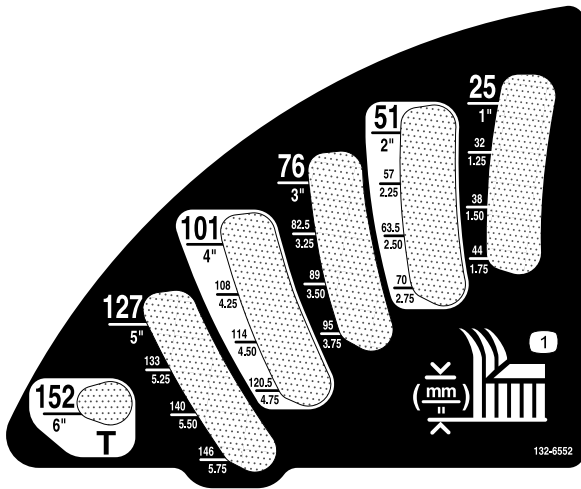

132-6552

2-Wheel Drive with ROPS and 4-Wheel Drive with ROPS Models Only

decal132-6552

1. Height of cut

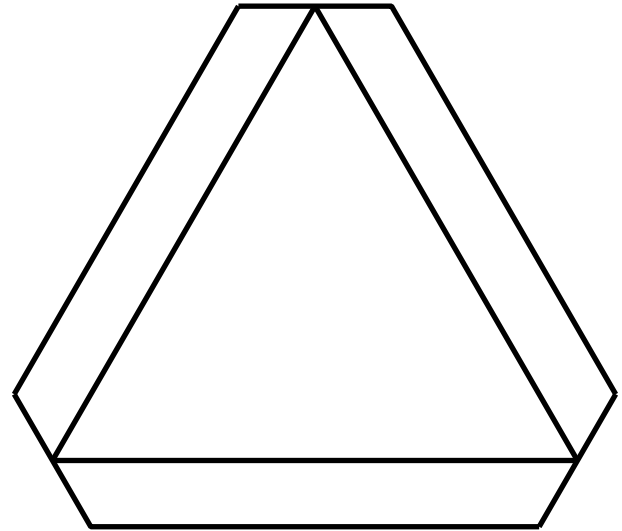

120-0250

decal120-0250

1. Slow-moving vehicle

✓ 8 GROUNDMASTER 360

	15	16	17	18										
1														
6	15W-40 CJ-4	5.5 QTS 5.2 L	250	250	125-7025									
12	MOBIL 424	4.5 GALS 17 L	800	800	108-5194									
13				108-3810										
5				400	125-2915									
8	<table border="1" style="font-size: small;"> <tr> <td style="text-align: center;">> 32° F > 0° C</td> <td>NO. 2-DIESEL</td> <td>13.5 GALS 51.1 L</td> <td rowspan="2" style="text-align: center;">2 YRS</td> <td rowspan="2" style="text-align: center;">400</td> <td rowspan="2"></td> </tr> <tr> <td style="text-align: center;">< 32° F < 0° C</td> <td>NO. 2-DIESEL</td> <td></td> </tr> </table>	> 32° F > 0° C	NO. 2-DIESEL	13.5 GALS 51.1 L	2 YRS	400		< 32° F < 0° C	NO. 2-DIESEL					125-8752
> 32° F > 0° C	NO. 2-DIESEL	13.5 GALS 51.1 L	2 YRS	400										
< 32° F < 0° C	NO. 2-DIESEL													
4	50% WATER 50% ETHYL GLYCOL	6 QTS 5.7 L	2 YRS											
11	80W-90 GEAR OIL SYNTH: Mobilube SHC 75W-90	14 FL OZ 414mL	400	400										

144-7256

decal144-7256

144-7256

- | | |
|---|--|
| <ol style="list-style-type: none"> 1. Read the <i>Operator's Manual</i> before performing maintenance. 2. Fan belt tension 3. Radiator screen 4. Engine coolant 5. Fuel/water separator 6. Engine oil 7. Tire pressure 8. Fuel 9. Belt tension | <ol style="list-style-type: none"> 10. Parking brake 11. Gearbox 12. Hydraulic fluid 13. Engine air filter 14. Battery 15. Fluid specifications 16. Capacity 17. Fluid interval (hours) 18. Filter interval (hours) |
|---|--|

Setup

Loose Parts

Use the chart below to verify that all parts have been shipped.

Procedure	Description	Qty.	Use
1	PTO driveshaft	1	Install the PTO driveshaft to a optional cutting unit or QAS.
	Bolt (5/16 x 1-3/4 inches)	4	
	Locknut (5/16 inch)	4	
	Roll pin (3/16 x 1-1/2 inches)	2	
2	Retainer pin	2	Use the hardware to install the optional cutting unit.
	Grease fitting	2	
	Washer head screw (5/16 x 7/8 inch)	2	
3	No parts required	–	Adjust the roll bar.
4	No parts required	–	Check the tire pressure.
5	No parts required	–	Check the hydraulic fluid, engine oil, and coolant levels.
6	Production-year decal	1	Install the decal (CE machines only).

Media and Additional Parts

Description	Qty.	Use
Operator's Manual	1	Review it before operating the machine.
Engine owner's manual	1	Use it to reference engine information.
Ignition keys	2	Start the engine.

1

Installing the PTO Driveshaft to an Optional Cutting Unit or QAS

Parts needed for this procedure:

1	PTO driveshaft
4	Bolt (5/16 x 1-3/4 inches)
4	Locknut (5/16 inch)
2	Roll pin (3/16 x 1-1/2 inches)

Procedure

Note: Installing the PTO driveshaft is easier if you position the machine on a hoist.

1. Park the machine on a level surface, engage the parking brake, shut off the engine, and remove the key.

⚠ WARNING

If you start the engine and allow the PTO to rotate, serious personal injury and machine damage could result.

- Do not start the engine and engage the PTO switch when the PTO driveshaft is disconnected from the cutting deck.
- Before you disconnect the PTO driveshaft from the cutting deck, disconnect the PTO solenoid-valve-coil connector from the wire harness to prevent unintentionally engaging the PTO clutch.

2. Disconnect the wire-harness connector from the PTO solenoid-valve-coil connector ([Figure 3](#)).

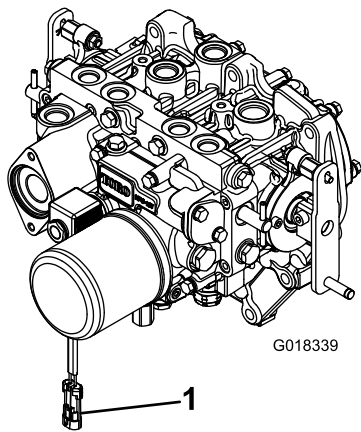

Figure 3

G018339

1. Wire-harness connector

3. Position the PTO driveshaft under the front of the machine. Ensure that the slip-shaft yoke of the driveshaft is positioned toward the transmission driveshaft (Figure 4).

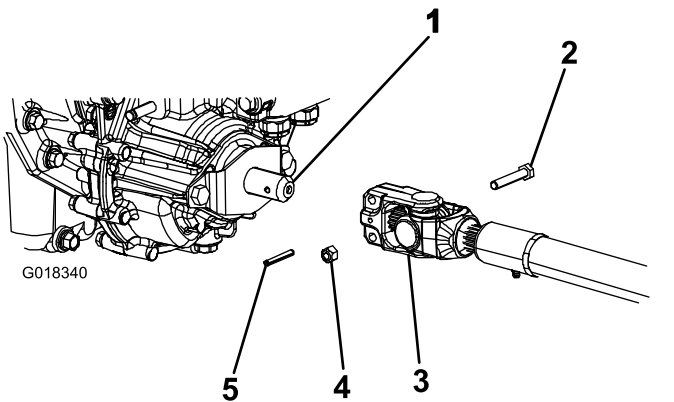

Figure 4

G018340

1. Transmission driveshaft
2. Bolt
3. PTO driveshaft
4. Locknut
5. Roll pin

4. Align the spline and roll-pin hole of the driveshaft yoke with the transmission driveshaft.
5. Slide the PTO driveshaft end yoke onto the transmission driveshaft.
6. Secure the end yoke of the PTO driveshaft as follows:
 - A. Install the roll pin in the end yoke and shaft.
 - B. Install the bolts through the driveshaft end yoke.
 - C. Install and tighten the locknuts to secure the end yoke to the PTO driveshaft.

Note: Retain the remaining bolts, locknuts, and roll pin to secure the other end of the driveshaft to the attachment gearbox shaft.

- D. Torque the locknuts to 20 to 25 N·m (175 to 225 in-lb).

7. Lubricate the grease fittings on the PTO driveshaft.
8. After you connect the other end of the driveshaft to the attachment gearbox shaft, connect the wire-harness connector to the PTO solenoid-valve-coil connector (Figure 3).

2

Using the Optional Cutting-Unit-Mounting Hardware

Parts needed for this procedure:

2	Retainer pin
2	Grease fitting
2	Washer head screw (5/16 x 7/8 inch)

Procedure

Note: These components and procedure are required only if a cutting unit that requires retainer pins is mounted to the traction unit. Refer to the cutting unit *Operator's Manual* for the installation instructions.

Note: If you are not installing a cutting unit on the traction unit, remove or tie up the 4 deck-lift chains from the lift suspension.

3

Adjusting the Roll Bar

No Parts Required

Procedure

1. Remove the hairpin cotters and the pins from the roll bar (Figure 5).
2. Raise the roll bar to the upright position and install the 2 pins and secure them with the hairpin cotters (Figure 5).

Note: If you must lower the roll bar, push the bar forward to relieve pressure on the pins, remove the pins, lower the bar slowly, and secure it with the pins so that it does not damage the hood.

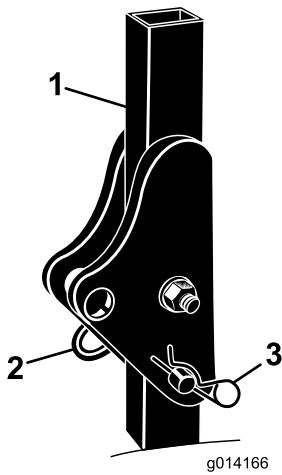

Figure 5

1. Roll bar
2. Pin
3. Hairpin cotter

3. Check the cooling system before starting the engine; refer to [Checking the Cooling System \(page 60\)](#).

6

Installing the Decal (CE Machines Only)

Parts needed for this procedure:

1	Production-year decal
---	-----------------------

Procedure

On machines requiring CE compliance, install the production-year decal included in the loose parts and the CE Kit, sold separately ([Figure 6](#)).

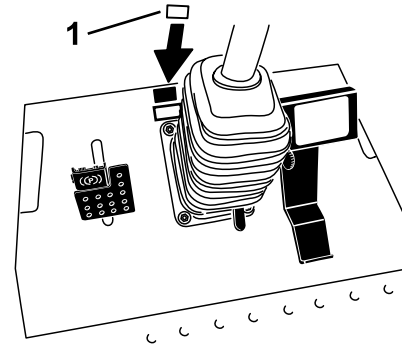

Figure 6

1. Production-year decal

4

Checking the Tire Pressure

No Parts Required

Procedure

Check the tire pressure; refer to [Checking the Tire Pressure \(page 58\)](#).

Important: Maintain pressure in all tires to ensure a good quality-of-cut and proper machine performance. Do not underinflate the tires.

5

Checking the Fluid Levels

No Parts Required

Procedure

1. Check the hydraulic-fluid level before starting the engine, refer to [Checking the Hydraulic System \(page 64\)](#).
2. Check the engine-oil level before starting the engine, refer to [Checking the Engine-Oil Level \(page 53\)](#).

Product Overview

Controls

Become familiar with all the controls before you start the engine and operate the machine.

Traction Pedal

The traction pedal (Figure 7) controls the forward and reverse operation. Press the top of the pedal to move forward and the bottom to move rearward. The ground speed depends on how far you press the pedal. For no load, maximum ground speed, fully press the pedal while the throttle is in the FAST position.

To stop the machine, reduce the foot pressure on the traction pedal and allow it to return to the center position.

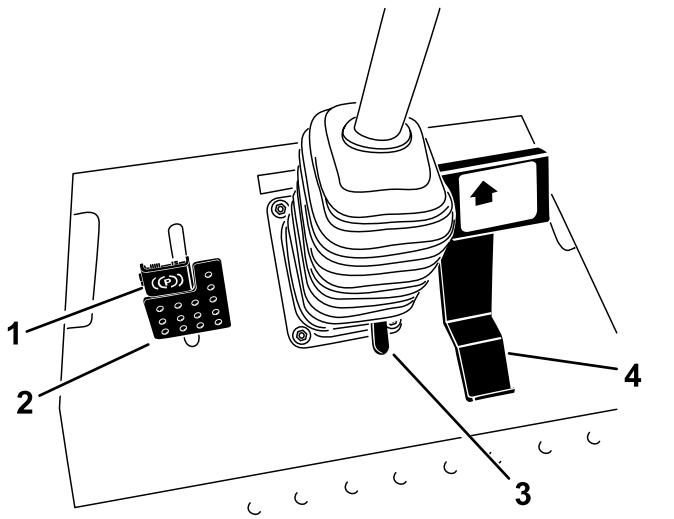

Figure 7

- | | |
|------------------|------------------------|
| 1. Parking brake | 3. Tilt-steering pedal |
| 2. Brake pedal | 4. Traction pedal |

Brake Pedal

Use the brake pedal with the brake-pedal latch to engage and disengage the parking brake (Figure 7). To stop the machine, release the traction pedal and allow it to return to the center position. You can use the brake to assist in stopping the machine in an emergency situation.

Tilt-Steering Pedal

To tilt the steering wheel toward you, press the foot pedal down, pull the steering tower toward you to the most comfortable position, and release the pedal (Figure 7). To move the steering wheel away from

you, press the foot pedal and release it when the steering wheel reaches the desired operating position.

Key Switch

The key switch has 3 positions: OFF, ON/PREHEAT, and START (Figure 8).

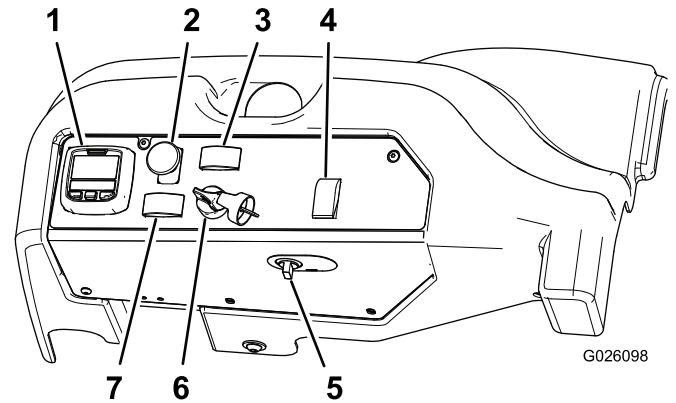

Figure 8

- | | |
|-------------------------------|---------------------|
| 1. InfoCenter | 5. Power point |
| 2. Power-takeoff (PTO) switch | 6. Key switch |
| 3. Engine-speed switch | 7. Deck-lift switch |
| 4. Steering selector switch | |

Engine-Speed Switch

The engine-speed switch (Figure 8) has 2 modes to change the engine speed. By momentarily tapping the switch, you can increase or decrease the engine speed in increments of 100 rpm. Press and hold the switch to set the engine speed directly to high or low idle, depending on which end of the switch you press.

Power-Takeoff (PTO) Switch

The power-takeoff (PTO) switch starts and stops the attachment (Figure 8).

Power Point

The power point provides a 12 V power supply for electronic devices (Figure 8).

InfoCenter LCD Display

The InfoCenter LCD display (Figure 8) shows information about your machine, such as the operating status, various diagnostics, and other information about the machine

The screens that display depend on which buttons you select. The purpose of each button may change depending on what is required at the time.

Important: If the cutting unit shuts down and the InfoCenter temperature-warning icon is on, push the PTO knob down; drive to a safe, flat area; move the throttle lever to the SLOW position; allow the traction pedal to move to the NEUTRAL position; and engage the parking brake. Allow the engine to idle for several minutes while it cools to a safe level. Shut off the engine and check the cooling system; refer to [Checking the Cooling System](#) (page 60).

Cab Controls

Model with Cab Only

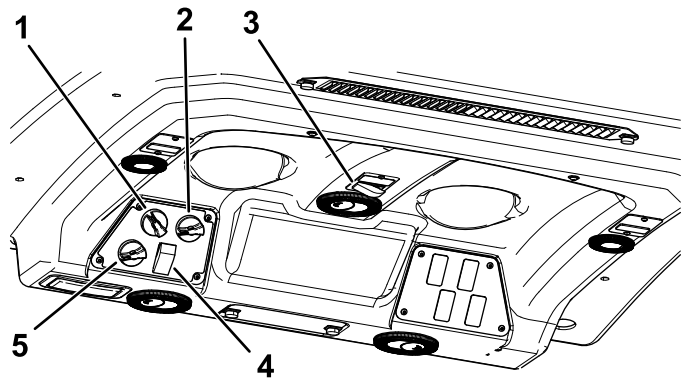

Figure 9

g198816

- | | |
|----------------------------|------------------------------|
| 1. Fan control | 4. Air-conditioning switch |
| 2. Temperature control | 5. Air-recirculation control |
| 3. Windshield-wiper switch | |

Air-Recirculation Control

Sets the cab to either recirculate the air in the cabin or to draw air into the cabin from outside (Figure 9).

- Set it to recirculate the air when using the air-conditioning.
- Set it to draw air in when using the heater or fan.

Fan-Control Knob

Rotate the fan-control knob to regulate the speed of the fan (Figure 9).

Temperature-Control-Knob

Rotate the temperature-control knob to regulate the air temperature in the cab (Figure 9).

Windshield-Wiper Switch

Use this switch to turn the wind shield wipers on or off (Figure 9).

Air-Conditioning Switch

Use this switch to turn the air conditioning on or off (Figure 9).

Windshield Latch

Lift up the latch to open the windshield (Figure 10). Press in the latch to lock the windshield in the open position. Pull out and down on the latch to close and secure the windshield.

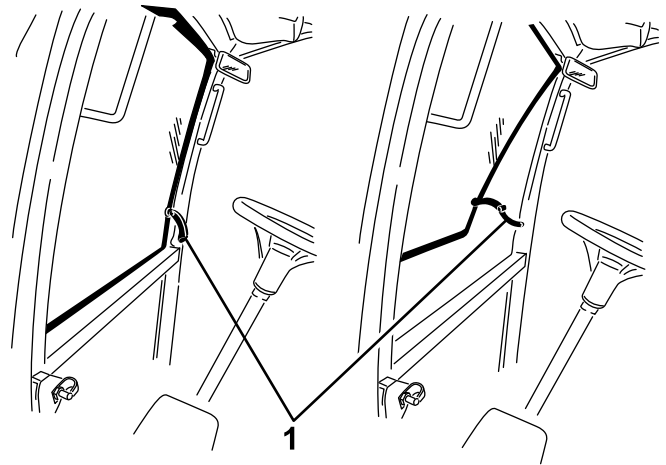

Figure 10

g196911

1. Windshield latch

Rear Window Latch

Lift up the latches to open the rear window. Press in on the latch to lock the window in OPEN position. Pull out and down on the latch to close and secure the window (Figure 10).

Important: Close the rear window before opening the hood or damage may occur to the hood or rear window.

Fuel Gauge

The fuel gauge (Figure 11) indicates the amount of fuel remaining in the fuel tank.

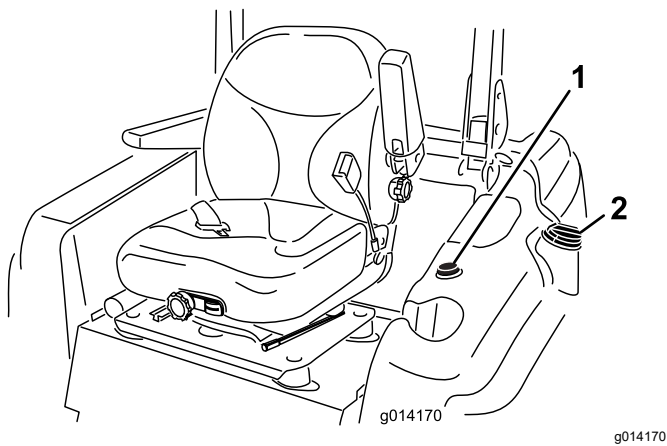

Figure 11

1. Fuel gauge
 2. Fuel-tank cap
-

Setting the Auto Idle

1. In the Settings Menu, scroll down to Auto Idle.
2. Press the right button to change the auto idle time between OFF, 8S, 10S, 15S, 20S, and 30S.

Specifications

Note: Specifications and design are subject to change without notice.

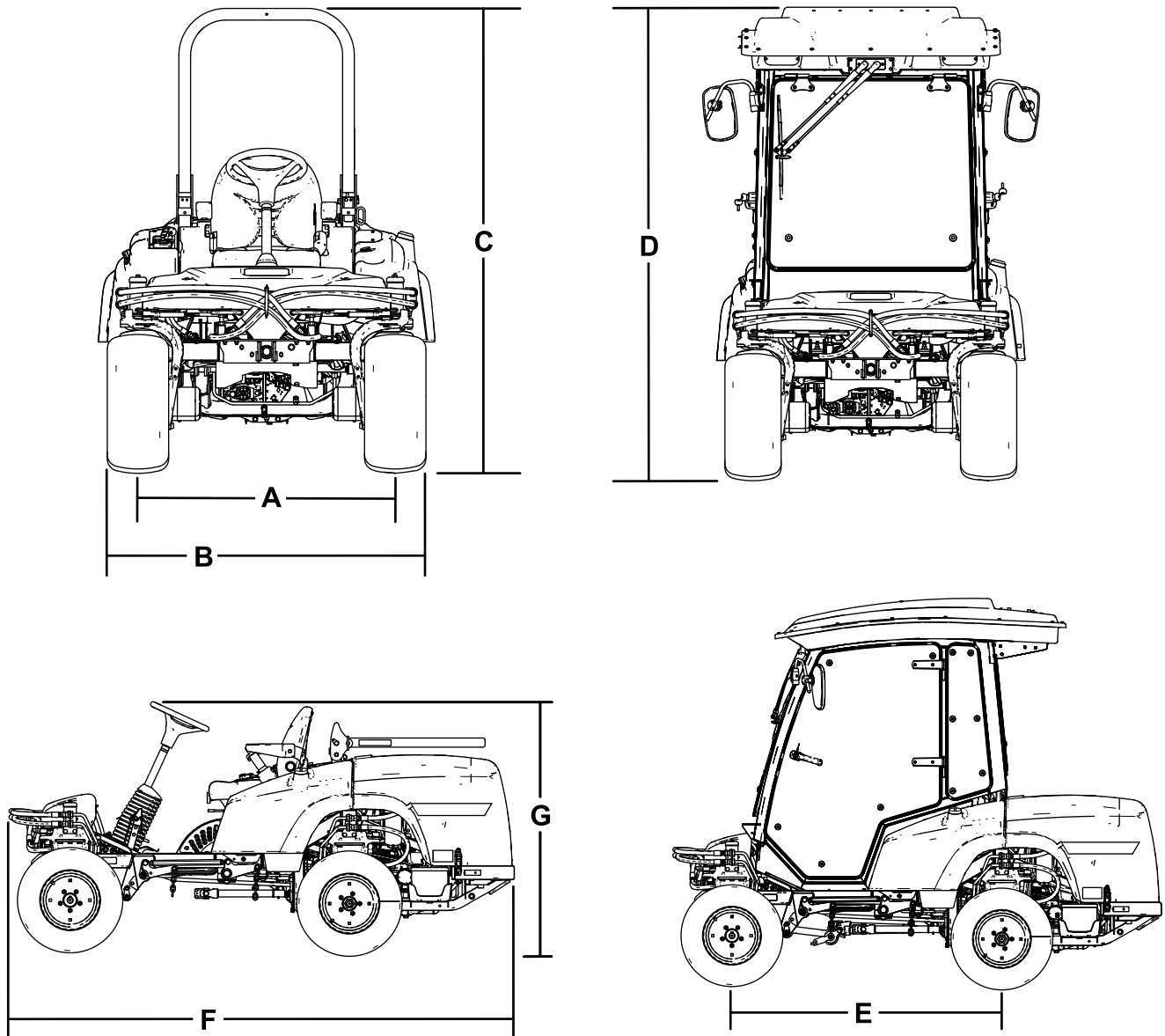

Figure 12

g198083

Description	Figure 12 Reference	Dimension or Weight
Height with roll bar up	C	202 cm (80 inches)
Height with roll bar down	G	140 cm (55 inches)
Height with cab	D	225 cm (88-1/2 inches)
Overall length	F	276 cm (108-1/2 inches)
Overall width	B	138 cm (54 inches)
Wheel base	E	155 cm (61 inches)
Wheel tread (tire center to center) rear	A	112 cm (44 inches)
Ground clearance		15 cm (6 inches)

Weight of the Machine with Cutting Units

	4-Wheel Drive Machine with ROPS	Machine with Cab	2-Wheel Drive Machine with ROPS
No cutting unit	1,152 kg (2,540 lb)	1,435 kg (3,163 lb)	1,130 kg (2,492 lb)
72 inch side discharge cutting unit	1,363 kg (3,004 lb)	1,645 kg (3,627 lb)	1,341 kg (2,956 lb)
72 inch base cutting unit	1,341 kg (2,956 lb)	1,623 kg (3,579 lb)	1,319 kg (2,908 lb)
62 inch base cutting unit	1,324 kg (2,918 lb)	1,606 kg (3,541 lb)	1,302 kg (2,870 lb)
100 inch rear discharge cutting unit	1,510 kg (3,330 lb)	1,793 kg (3,953 lb)	1,489 kg (3,282 lb)

Attachments/Accessories

A selection of Toro approved attachments and accessories is available for use with the machine to enhance and expand its capabilities. Contact your Authorized Service Dealer or authorized Toro distributor or go to www.Toro.com for a list of all approved attachments and accessories.

To ensure optimum performance and continued safety certification of the machine, use only genuine Toro replacement parts and accessories. Replacement parts and accessories made by other manufacturers could be dangerous, and such use could void the product warranty.

Operation

Note: Determine the left and right sides of the machine from the normal operating position.

Before Operation

Before Operation Safety

General Safety

- Never allow children or untrained people to operate or service the machine. Local regulations may restrict the age of the operator. The owner is responsible for training all operators and mechanics.
- Become familiar with the safe operation of the equipment, operator controls, and safety signs.
- Shut off the engine, remove the key, and wait for all movement to stop before you leave the operator's position. Allow the machine to cool before adjusting, servicing, cleaning, or storing it.
- Know how to stop the machine and shut off the engine quickly.
- Check that operator-presence controls, safety switches, and guards are attached and functioning properly. Do not operate the machine unless they are functioning properly.
- Before mowing, always inspect the machine to ensure that the blades, blade bolts, and cutting assemblies are in good working condition. Replace worn or damaged blades and bolts in sets to preserve balance.
- Inspect the area where you will use the machine and remove all objects that the machine could throw.

Fuel Safety

- Use extreme care in handling fuel. It is flammable and its vapors are explosive.
- Extinguish all cigarettes, cigars, pipes, and other sources of ignition.
- Use only an approved fuel container.
- Do not remove the fuel cap or fill the fuel tank while the engine is running or hot.
- Do not add or drain fuel in an enclosed space.
- Do not store the machine or fuel container where there is an open flame, spark, or pilot light, such as on a water heater or other appliance.
- If you spill fuel, do not attempt to start the engine; avoid creating any source of ignition until the fuel vapors have dissipated.

Adding Fuel

Fuel Specification

Important: Use only ultra-low sulphur diesel fuel. Fuel with higher rates of sulfur degrades the diesel oxidation catalyst (DOC), which causes operational problems and shortens the service life of engine components.

Failure to observe the following cautions may damage the engine.

- Never use kerosene or gasoline instead of diesel fuel.
- Never mix kerosene or used engine oil with the diesel fuel.
- Never keep fuel in containers with zinc plating on the inside.
- Do not use fuel additives.

Petroleum Diesel

Cetane rating: 45 or higher

Sulfur content: Ultra-low sulfur (<15 ppm)

Fuel Table

Diesel fuel specification	Location
ASTM D975 No. 1-D S15 No. 2-D S15	USA
EN 590	European Union
ISO 8217 DMX	International
JIS K2204 Grade No. 2	Japan
KSM-2610	Korea

- Use only clean, fresh diesel fuel or biodiesel fuels.
- Purchase fuel in quantities that can be used within 180 days to ensure fuel freshness.

Use summer-grade diesel fuel (No. 2-D) at temperatures above -7°C (20°F) and winter-grade fuel (No. 1-D or No. 1-D/2-D blend) below that temperature.

Note: Use of winter-grade fuel at lower temperatures provides lower flash point and cold flow characteristics which eases starting and reduces fuel filter plugging.

Using summer-grade fuel above -7°C (20°F) contributes toward longer fuel pump life and increased power compared to winter-grade fuel.

Biodiesel

This machine can also use a biodiesel blended fuel of up to B20 (20% biodiesel, 80% petroleum diesel).

Sulfur content: Ultra-low sulfur (<15 ppm)

Biodiesel fuel specification: ASTM D6751 or EN14214

Blended fuel specification: ASTM D975, EN590, or JIS K2204

Important: The petroleum diesel portion must be ultra-low sulfur.

Observe the following precautions:

- Biodiesel blends may damage painted surfaces.
- Use B5 (biodiesel content of 5%) or lesser blends in cold weather.
- Monitor seals, hoses, gaskets in contact with fuel as they may be degraded over time.
- Fuel filter plugging may be expected for a time after converting to biodiesel blends.
- Contact your authorized Toro distributor if you wish for more information on biodiesel.

Fuel Tank Capacity

51 L (13.5 US gallons)

Filling the Fuel Tank

Note: If possible, fill the fuel tank after each use. This minimizes possible buildup of condensation inside the fuel tank.

Add fuel to the fuel tank until the level is even with the bottom of the filler neck. **Do not overfill the fuel tank.**

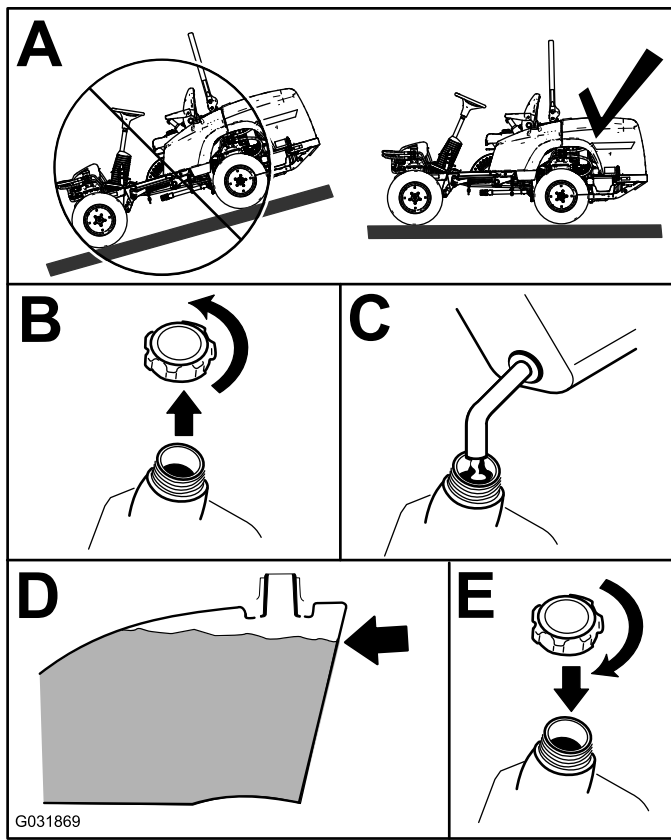

Figure 13

The Safety-Interlock System

⚠ CAUTION

If the safety-interlock switches are disconnected or damaged, the machine could operate unexpectedly, causing personal injury.

- Do not tamper with the interlock switches.
- Check the operation of the interlock switches daily and replace any damaged switches before operating the machine.

Understanding the Safety Interlock System

The safety-interlock system is designed to prevent the engine from starting unless the following occurs:

- You are sitting on the seat or the parking brake is engaged.
- The power takeoff (PTO) is disengaged.
- The traction pedal is in the NEUTRAL position.
- The engine temperature is below the maximum operating temperature.

The safety-interlock system is also designed to shut off the engine when you move the traction pedal from the NEUTRAL position with the parking brake engaged. If you rise from the seat when the PTO is engaged there is a 1-second delay and then the engine shuts off.

Checking the Engine-Oil Level

Before you start the engine and use the machine, check the oil level in the engine crankcase; refer to [Checking the Engine-Oil Level \(page 53\)](#).

Checking the Cooling System

Before you start the engine and use the machine, check the cooling system; refer to [Checking the Cooling System \(page 60\)](#).

Checking the Hydraulic System

Before you start the engine and use the machine, check the hydraulic system; refer to [Checking the Hydraulic System \(page 64\)](#).

Testing the Safety-Interlock System

Service Interval: Before each use or daily

Test the safety interlock system before you use the machine each time. If the safety system does not operate as described below, have an authorized Toro distributor repair the safety system immediately.

1. Sitting on the seat, engage the parking brake and move the PTO to the ON position. Try starting the engine; the engine should not start.
2. Sitting on the seat, engage the parking brake and move the PTO to the OFF position. Press the traction pedal. Try starting the engine; the engine should not start.
3. Sitting on the seat, engage the parking brake, move the PTO switch to the OFF position, and allow the traction pedal to return to the NEUTRAL position. Now start the engine. While the engine is running, disengage the parking brake, engage the PTO and rise slightly from the

seat. On 2-wheel-drive machines, the engine should stop within 2 seconds. On 4-wheel-drive machines, the cutting unit shuts off and the engine continues to run.

4. Without sitting on the seat, engage the parking brake, move the PTO switch to the OFF position, and move the traction pedal to the NEUTRAL position. Now start the engine. While the engine is running, press the traction pedal; the engine should shut off within 2 seconds.
5. Without an operator on the seat, disengage the parking brake, move the PTO switch to off, and allow the traction pedal to return to the NEUTRAL position. Try starting the engine; the engine should not start.

Positioning the Standard Seat

Changing the Seat Position

The seat can move forward and backward. Position the seat where you have the best control of the machine and are most comfortable.

1. To adjust the seat, move the lever sideways to unlock the seat (Figure 14).

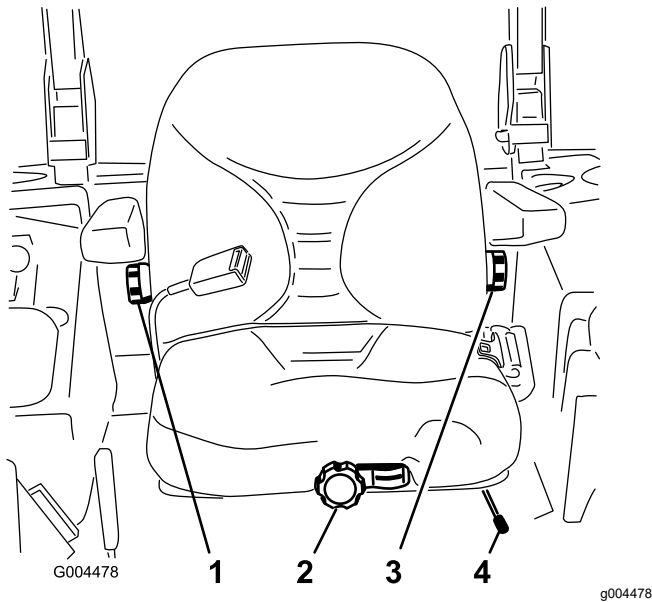

Figure 14

- | | |
|-------------------------|-----------------------------------|
| 1. Backrest knob | 3. Lumbar-support-adjustment knob |
| 2. Seat-suspension knob | 4. Seat-position-adjustment lever |

2. Slide the seat to the desired position and release the lever to lock the seat in position.
3. Verify that the seat has locked into place by attempting to move it back and forth.

Changing the Seat Suspension

You can adjust the seat to provide a smooth and comfortable ride. Position the seat where you are most comfortable.

Without sitting on the seat, turn the knob in front in either direction to provide the best comfort (Figure 15).

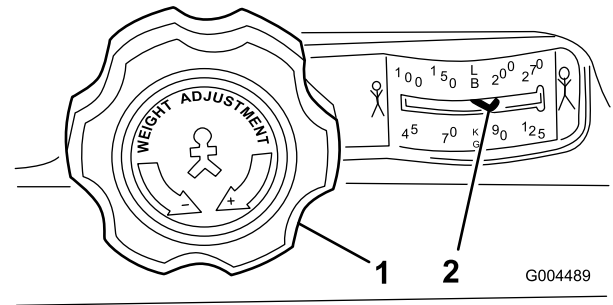

Figure 15

1. Seat-suspension knob
2. Operator-weight setting

Changing the Back Position

You can adjust the back of the seat to provide a comfortable ride. Position the back of the seat where it is most comfortable.

To adjust the back of the seat, turn the knob, located under the right-side armrest, in either direction to provide the best comfort (Figure 14).

Changing the Lumbar Support

You can adjust the back of the seat to provide a customized lumbar support for your lower back.

To adjust the back of the seat, turn the knob, under the left-side armrest, in either direction to provide the best comfort (Figure 14).

Raising and Lowering the Seat

To access the hydraulic and other systems under the seat, you must unlatch the seat and swing it forward.

1. Move the seat latch, located on the left side of the seat, rearward to unlatch the seat and pull forward on the top of the seat (Figure 16).

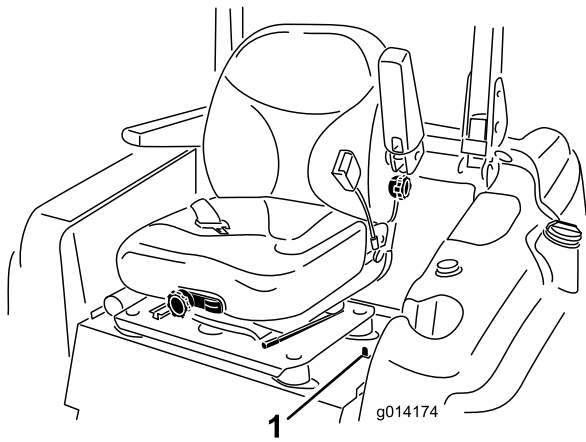

Figure 16

g014174

1. Seat latch
-
2. To lower the seat, pull up the seat-latch-release bar and lower the seat into the locked position.

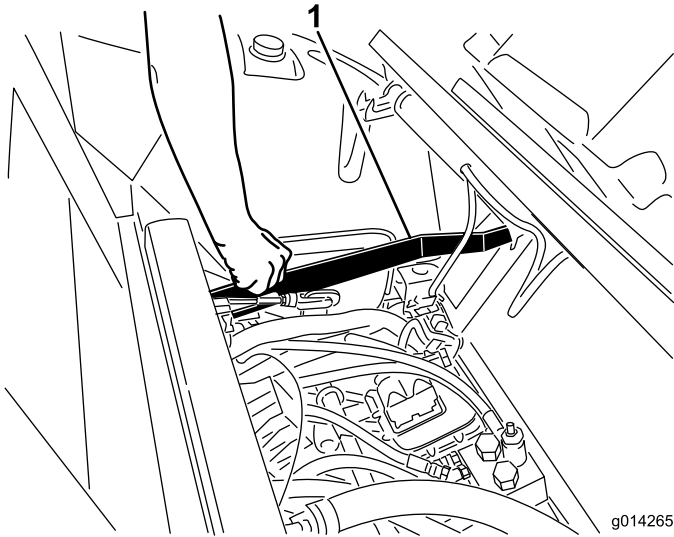

Figure 17

g014265
g014265

1. Seat-latch-release bar

Adjusting the Height of Cut

You can adjust the height of cut from 2.5 to 15.8 cm (1 to 6 inches) in 6 mm (1/4 inch) increments by relocating the height-of-cut pin into different hole locations.

1. With the engine running, push back the deck-lift switch until the cutting unit is fully raised, and **release the switch immediately** as shown in [Figure 18](#).
2. Rotate the height-of-cut pin until the nub on it lines up with the slots in the holes in the height-of-cut bracket and remove it ([Figure 18](#)).
3. Select a hole in the height-of-cut bracket corresponding to the desired height of cut, insert

the pin, and rotate it down to lock it in place ([Figure 18](#)).

Note: There are 4 rows of hole positions ([Figure 18](#)). The top row gives you the height of cut listed above the pin. The second row down gives you the height listed plus 6 mm (1/4 inch). The third row down gives you the height listed plus 12 mm (1/2 inch). The bottom row gives you the height listed plus 18 mm (3/4 inch). For the 15.8 cm (6 inches) position, there is only 1 hole, located in the second row. This does not add 6 mm (1/4 inch) to the 15.8 cm (6 inches) position.

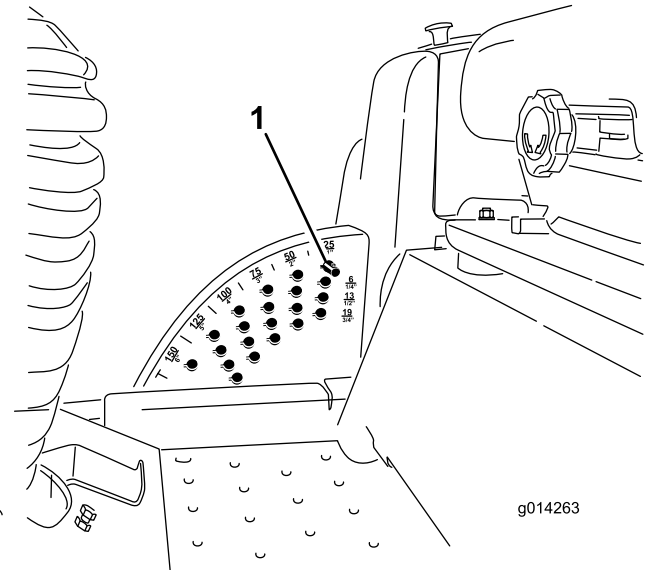

Figure 18

g014263

g014263

1. Height-of-cut pin

4. Adjust the anti-scalp rollers and skids as required.

Using the InfoCenter LCD Display

The InfoCenter LCD display shows information about your machine, such as the operating status, various diagnostics, and other information about the machine ([Figure 19](#)). There is a splash screen and main information screen of the InfoCenter. You can switch between the splash screen and main information screen at any time by pressing any of the InfoCenter buttons and then selecting the appropriate directional arrow.

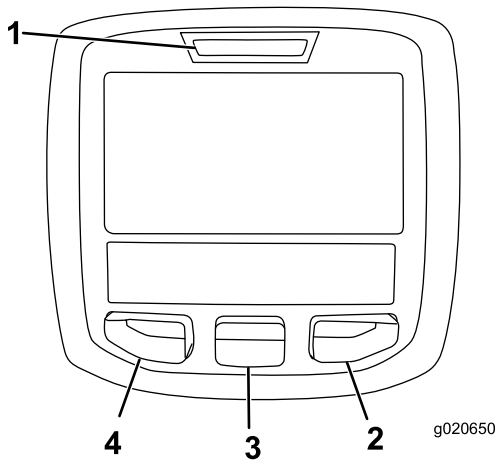

Figure 19

- 1. Indicator light
- 2. Right button
- 3. Middle button
- 4. Left button

- Left button, menu access/back button—press this button to access the InfoCenter menus. You can use it to back out of any menu that you are currently using.
- Middle button—use this button to scroll down menus.
- Right button—use this button to open a menu where a right arrow indicates additional content.

Note: The purpose of each button may change depending on what is required at the time. Each button is labeled with an icon displaying its current function.







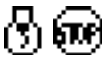

InfoCenter Icon Description

SERVICE DUE	Indicates when scheduled service should be performed
	Engine rpm/status—indicates the engine rpm
	Hour meter
	Info icon
	Fast
	Slow
	Glow plugs are active
	AC
	2-wheel steer

InfoCenter Icon Description (cont'd.)

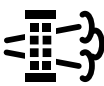
	4-wheel steer
	Operator must sit in seat
	Parking brake indicator—indicates when the parking brake is set
	Coolant Temperature—indicates the engine coolant temperature in either °C or °F
	Temperature (hot)
	PTO is engaged
	Denied or not allowed
	Engine start
	Stop or shutdown
	Engine
	Key switch
PIN	PIN code
CAN	CAN bus
	InfoCenter
Bad	Bad or failed
	Bulb
OUT	Output of TEC controller or control wire in harness
	Switch
	Operator must release switch
	Operator should change to indicated state
Symbols are often combined to form sentences. Some examples are shown below	
	Operator should put machine in Neutral

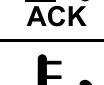
InfoCenter Icon Description (cont'd.)

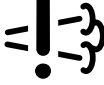
	Engine start denied
	Engine shutdown
	Engine coolant too hot
	Sit down or engage parking brake
 48.1g/l	DPF ash accumulation notification. Refer to Servicing the Diesel-Oxidation Catalyst (DOC) and the Soot Filter (page 54) for details.
	Reset-standby regeneration request
	Parked or recovery regeneration request
 ACK	A parked or recovery regeneration is processing.
	High exhaust temperature
	NOx control diagnosis malfunction; drive the machine back to the shop and contact your authorized Toro distributor (software version T and later).

Using the Menus

To access the InfoCenter menu system, press the menu access button while at the main screen. This brings you to the main menu. Refer to the following tables for a synopsis of the options available from the menus:

Main Menu	
Menu Item	Description
Faults	The Faults menu contains a list of the recent machine faults. Refer to the Service Manual or your authorized Toro distributor for more information on the Faults menu and the information contained there.
Service	The Service menu contains information on the machine such as hours of use counters and other similar numbers.

Diagnostics	The Diagnostics menu displays the state of each machine switch, sensor and control output. You can use this to troubleshoot certain issues as it will quickly tell you which machine controls are on and which are off.
Settings	The Settings menu allows you to customize and modify configuration variables on the InfoCenter display.
About	The About menu lists the model number, serial number, and software version of your machine.

Service	
Menu Item	Description
Hours	Lists the total number of hours that the machine, engine, and PTO have been on, as well as the number of hours the machine has been transported and service due
Counts	Lists numerous counts the machine has experienced

Diagnostics	
Menu Item	Description
PTO	Indicates the inputs, qualifiers, and outputs for enabling the PTO circuit
Engine Run	Indicates the inputs, qualifiers, and outputs for starting the engine
Decks	Indicates the inputs, qualifiers, and outputs for lifting and lowering the deck
Steer Mode	Indicates the inputs, qualifiers, and outputs for switching between 2-wheel steer and 4-wheel steer
Machine Input	Indicates the state of other machine inputs such as accessories and A/C clutch

Settings	
Menu Item	Description
Units	Controls the units used on the InfoCenter; The menu choices are English or Metric.
Language	Controls the language used on the InfoCenter*
LCD Backlight	Controls the brightness of the LCD display
LCD Contrast	Controls the contrast of the LCD display

Protected Menu	Allows a person authorized by your company with the PIN code to access protected menus.
Auto Idle	Controls the amount of time allowed before returning the engine to low idle when the machine is stationary

Only operator-faced text is translated. Faults, Service, and Diagnostics screens are service-faced. The titles are in the selected language, but the menu items are in English.

About	
Menu Item	Description
Model	Lists the model number of the machine
SN	Lists the serial number of the machine
Machine Controller Revision	Lists the software revision of the master controller
InfoCenter Revision	Lists the software revision of the InfoCenter
CAN Bus	Lists the machine communication bus status

Protected Menu

There are 2 operating configuration settings that are adjustable within the Settings Menu of the InfoCenter: Auto Idle time delay and Stationary Regeneration; refer to [Accessing the DPF Regeneration Menus \(page 35\)](#). You can lock these settings by using the Protected Menu.

Note: At the time of delivery, the initial password code is programmed by your distributor.

Accessing Protected Menus

Note: The factory default PIN code for you machine is either 0000 or 1234.

If you changed the PIN code and forgot the code, contact your authorized Toro distributor for assistance.

1. From the MAIN MENU, use the center button to scroll down to the SETTINGS MENU and press the right button ([Figure 20](#)).

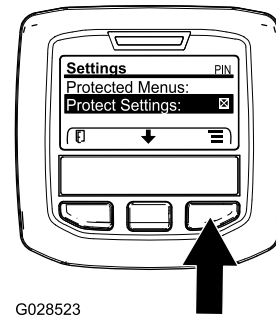

G028523

Figure 20

g028523

2. In the SETTINGS MENU, use the center button to scroll down to the PROTECTED MENU and press the right button ([Figure 21A](#)).

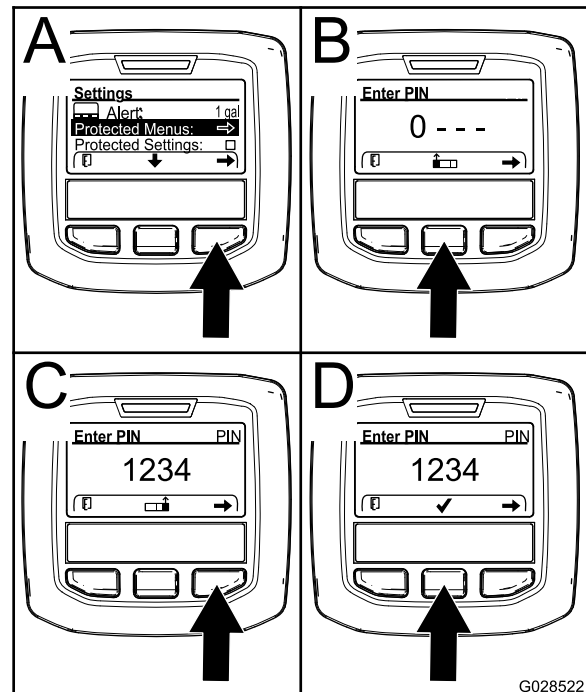

G028522

Figure 21

g028522

3. To enter the PIN code, press the center button until the correct first digit appears, then press the right button to move on to the next digit ([Figure 21B](#) and [Figure 21C](#)). Repeat this step until the last digit is entered and press the right button once more.
4. Press the middle button to enter the PIN code ([Figure 21D](#)).

Wait until the red indicator light of the InfoCenter illuminates.

Note: If the InfoCenter accepts the PIN code and the protected menu is unlocked, the word "PIN" displays in the upper right corner of the screen.

Note: Rotate the key switch to the OFF position and then to the ON position locks the protected menu.

You can view and change the settings in the Protected Menu. Once you access the Protected Menu, scroll down to Protect Settings option. Use the right button to change the setting. Setting the Protect Settings to OFF allows you to view and change the settings in the Protected Menu without entering the PIN code. Setting the Protect Settings to ON hides the protected options and requires you to enter the PIN code to change the setting in the Protected Menu. After you set the PIN code, rotate the key switch OFF and back to the ON position to enable and save this feature.

During Operation

During Operation Safety

General Safety

- The owner/operator can prevent and is responsible for accidents that may cause personal injury or property damage.
- Wear appropriate clothing, including eye protection; long pants; substantial, slip-resistant footwear; and hearing protection. Tie back long hair and do not wear loose clothing or loose jewelry.
- Do not operate the machine while ill, tired, or under the influence of alcohol or drugs.
- Use your full attention while operating the machine. Do not engage in any activity that causes distractions; otherwise, injury or property damage may occur.
- Before you start the engine, ensure that all drives are in neutral, the parking brake is engaged, and you are in the operating position.
- Do not carry passengers on the machine and keep bystanders and children out of the operating area.
- Operate the machine only in good visibility to avoid holes or hidden hazards.
- Avoid mowing on wet grass. Reduced traction could cause the machine to slide.
- Keep your hands and feet away from rotating parts. Keep clear of the discharge opening.
- Look behind and down before backing up to be sure of a clear path.
- Use care when approaching blind corners, shrubs, trees, or other objects that may obscure your vision.
- Stop the blades whenever you are not mowing.
- Stop the machine, remove the key, and wait for all moving parts to stop before inspecting the attachment after striking an object or if there is an abnormal vibration in the machine. Make all necessary repairs before resuming operation.
- Slow down and use caution when making turns and crossing roads and sidewalks with the machine. Always yield the right-of-way.
- Disengage the drive to the cutting unit, shut off the engine, remove the key, and wait for all movement to stop before adjusting the height of cut (unless you can adjust it from the operating position).
- Operate the engine only in well-ventilated areas. Exhaust gases contain carbon monoxide, which is lethal if inhaled.
- Never leave a running machine unattended.

- Before you leave the operator's position, do the following:
 - Park the machine on a level surface.
 - Disengage the power takeoff and lower the attachments.
 - Engage the parking brake.
 - Shut off the engine and remove the key.
 - Wait for all movement to stop.
- Operate the machine only in good visibility. Do not operate the machine when there is the risk of lightning.
- Do not use the machine as a towing vehicle.
- Use accessories, attachments, and replacement parts approved by Toro only.
- Lower a folding roll bar temporarily only when necessary. Do not wear the seat belt when the roll bar is folded down.
- Be aware that there is no rollover protection when a folded roll bar is in the down position.
- Check the area that you will be mowing and never fold down a folding roll bar in areas where there are slopes, drop-offs, or water.

Rollover Protection System (ROPS) Safety

- The ROPS is an integral and effective safety device.
- Do not remove any of the ROPS components from the machine.
- Ensure that the seat belt is attached to the machine.
- Pull the belt strap over your lap and connect the belt to the buckle on the other side of the seat.
- To disconnect the seat belt, hold the belt, press the buckle button to release the belt, and guide the belt into the auto-retract opening. Ensure that you can release the belt quickly in an emergency.
- Check carefully for overhead obstructions and do not contact them.
- Keep the ROPS in safe operating condition by thoroughly inspecting it periodically for damage and keeping all the mounting fasteners tight.
- Replace damaged ROPS components. Do not repair or alter them.

Additional ROPS Safety for Machines with a Cab or a Fixed Roll Bar

- A cab installed by Toro is a roll bar.
- Always wear your seat belt.

Additional ROPS Safety for Machines with a Foldable Roll Bar

- Keep a folding roll bar in the raised and locked position, and wear your seat belt when operating the machine with the roll bar in the raised position.

Slope Safety

- Slopes are a major factor related to loss of control and rollover accidents, which can result in severe injury or death. You are responsible for safe slope operation. Operating the machine on any slope requires extra caution.
- Evaluate the site conditions to determine if the slope is safe for machine operation, including surveying the site. Always use common sense and good judgment when performing this survey.
- Review the slope instructions listed below for operating the machine on slopes and to determine whether you can operate the machine in the conditions on that day and at that site. Changes in the terrain can result in a change in slope operation for the machine.
- Avoid starting, stopping, or turning the machine on slopes. Avoid making sudden changes in speed or direction. Make turns slowly and gradually.
- Do not operate a machine under any conditions where traction, steering, or stability is in question.
- Remove or mark obstructions such as ditches, holes, ruts, bumps, rocks, or other hidden hazards. Tall grass can hide obstructions. Uneven terrain could overturn the machine.
- Be aware that operating the machine on wet grass, across slopes, or downhill may cause the machine to lose traction. Loss of traction to the drive wheels may result in sliding and a loss of braking and steering.
- Use extreme caution when operating the machine near drop-offs, ditches, embankments, water hazards, or other hazards. The machine could suddenly roll over if a wheel goes over the edge or the edge caves in. Establish a safety area between the machine and any hazard.
- Identify hazards at the base of the slope. If there are hazards, mow the slope with a pedestrian-controlled machine.
- If possible, keep the cutting unit(s) lowered to the ground while operating on slopes. Raising the cutting unit(s) while operating on slopes can cause the machine to become unstable.
- Use extreme caution with grass-collection systems or other attachments. These can change the stability of the machine and cause a loss of control.

Using the Rollover-Protection System (ROPS)

⚠ WARNING

A rollover accident can cause injury or death.

- Keep the roll bar in the raised locked position.
- Use the seat belt.
- Ensure that the seat plate is secured with the seat latch.

⚠ WARNING

You have no rollover protection when the roll bar is in the down position.

- Lower the roll bar only when necessary.
- Do not wear the seat belt when the roll bar is in the down position.
- Drive slowly and carefully.
- Raise the roll bar as soon as clearance permits.
- Check carefully for overhead clearances (i.e., branches, doorways, electrical wires) before driving under any objects and do not contact them.

Raising the Roll Bar

Important: Always use the seat belt when the roll bar is in the raised and locked position.

1. Ensure that the seat is secured with the seat latch.
2. Remove the 2 hairpins and remove the 2 pins (Figure 22).

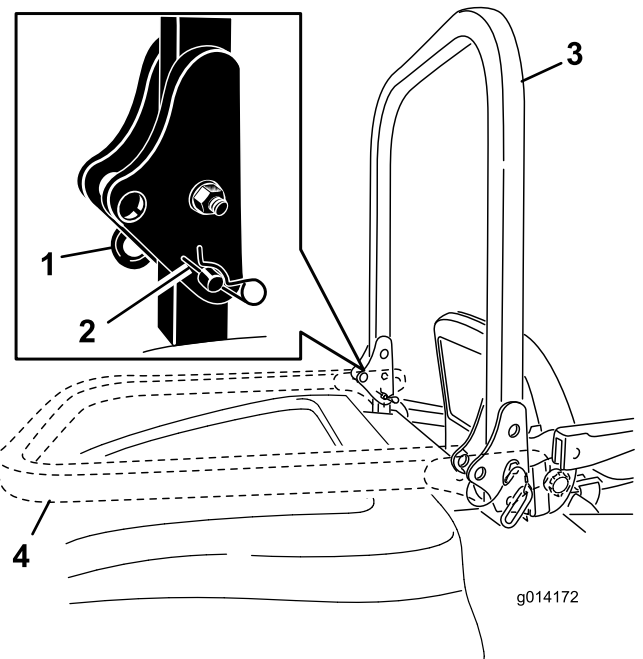

Figure 22

- | | |
|------------|--------------------------------|
| 1. Pin | 3. Roll bar (raised position) |
| 2. Hairpin | 4. Roll bar (lowered position) |

3. Raise the roll bar to the upright position (Figure 22).
4. Secure the roll bar with the 2 pins and 2 hairpins (Figure 22).

Lowering the Roll Bar

Important: Do not use the seat belt when the roll bar is in the lowered position.

1. Remove the hairpins, push the roll bar forward against the springs, and remove the 2 pins (Figure 22).
2. Lower the roll bar to the down position (Figure 22).
3. Install the 2 pins into the pivot plates and secure the pins with the 2 hairpins (Figure 22).

Starting the Engine

1. If installed, raise the roll bar up and lock it into place, sit on the seat, and fasten the seat belt.
2. Ensure that the traction pedal is in the NEUTRAL position.
3. Engage the parking brake.
4. Move the power-takeoff (PTO) switch to the OFF position (Figure 23).

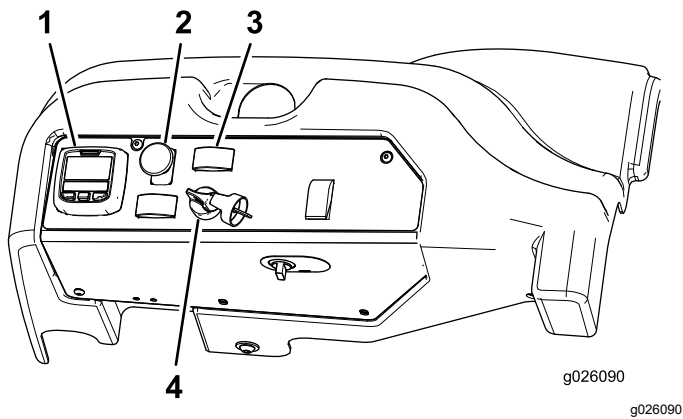

Figure 23

- | | |
|-------------------------------|------------------------|
| 1. InfoCenter | 3. Engine-speed switch |
| 2. Power-takeoff (PTO) switch | 4. Key switch |

- Turn the key clockwise to the RUN position.

Note: The InfoCenter glow-plug icon turns on in 6 seconds.

- After the InfoCenter glow-plug icon goes out, turn the key to the START position. When the engine starts, release the key.

Important: Use starting cycles of no more than 15 seconds per minute to avoid overheating the starter motor.

Note: Additional starting cycles may be required when starting the engine for the first time after the fuel system has been completely drained.

Important: When you start the engine for the first time, or after an engine oil change or an overhaul of the engine, the transmission, or a wheel motor, operate the machine with the engine-speed switch in the Slow position in both the forward and reverse directions for 1 to 2 minutes. Also operate the deck lift switch and the PTO switch to ensure proper operation of all the parts. Then shut the engine off and check the fluid levels and check for oil leaks, loose parts, and any other noticeable malfunctions.

Shutting Off the Engine

- Park the machine on a level surface.
- Disengage the PTO, make sure that the traction pedal is in the NEUTRAL position, engage the parking brake, and move the engine-speed switch to the idle position.
- Let the engine idle for 60 seconds.
- Turn the key to the OFF position.

- Remove the key to prevent the engine from accidentally starting and before you transport or store the machine.

Note: Remove the key; otherwise, the fuel pump or accessories may run and cause the battery to lose charge.

⚠ CAUTION

Children or bystanders may be injured if they move or attempt to operate the machine while it is unattended.

Always remove the key and engage the parking brake when leaving the machine unattended, even for a short period of time between operation.

Driving the Machine

The throttle control regulates the engine speed as measured in rpm (revolutions per minute). Place the throttle control in the FAST position for best performance. Always operate the throttle in the FAST position when mowing.

Stopping the Machine

To stop the machine, release the traction pedal to the NEUTRAL position.

Engage the parking brake whenever you leave the machine and remove the key.

Selecting the Steering Mode

For maximum trimming and minimum turf damage, operate the machine in the 4-wheel-steering mode. However, when transporting the machine on roads or trails, switch the machine into 2-wheel-steering mode.

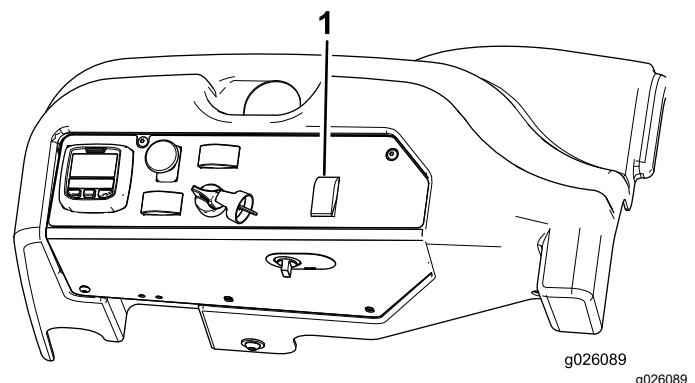

Figure 24

- Steering-selector switch

Switching from 4-Wheel Steering to 2-Wheel Steering

Press the steering-selector switch (Figure 24) to the forward position. When the wheels are not aligned in the forward position, the green light flashes and the machine remains in the 4-wheel-steering mode until the 4 tires point straight ahead. Turn the steering wheel slowly to straighten out the wheels until the green light stops flashing and remains on. When the switch light is solid green, the machine is in 2-wheel steering.

Note: If you turn the steering wheel too briskly, steering misalignment may occur.

Switching from 2-Wheel Steering to 4-Wheel Steering

Press the steering-selector switch (Figure 24) to the rearward position. When the front wheels are not aligned in the forward position, the green light flashes and the machine remains in 2-wheel-steering mode until the 4 tires point straight ahead. Turn the steering wheel slowly to straighten out the wheels until the green light stops flashing and remains off. When the switch light is continuously off, the machine is in the 4-wheel-steering mode.

Note: If you turn the steering wheel too briskly, steering misalignment may occur.

Note: If the steering system is misaligned after repeated 2-wheel-steering to 4-wheel-steering engagements, refer to [Correcting the Steering Misalignment](#) (page 58).

Operating the Cutting Unit or Attachment

Raising and Lowering the Cutting Unit/Attachment

The deck-lift switch raises and lowers the cutting unit/attachment (Figure 25). The engine must be running for you to use this switch.

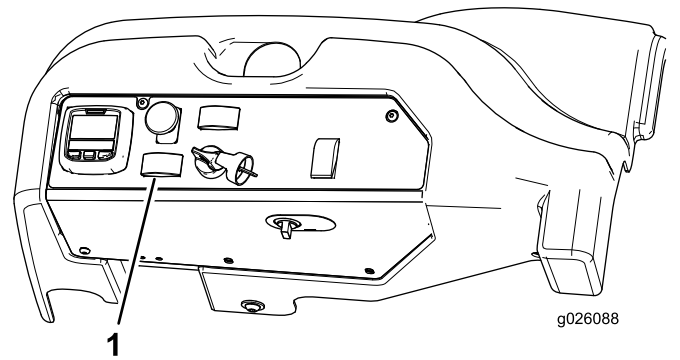

Figure 25

1. Deck-lift switch

- To lower the cutting unit/attachment, push the switch forward.
- To raise the mower deck/attachment, push the switch rearward.

Important: Do not continue to hold the switch back after the mower/attachment is fully raised. Doing so causes damage the hydraulic system.

Note: To lock the cutting unit/attachment in the raised position, raise the deck/attachment past the 15 cm (6 inch) position, remove the height-of-cut stop pin, and insert the pin into the 15 cm (6 inch) height-of-cut position; refer to [Adjusting the Height of Cut](#) (page 22).

Engaging the Power Takeoff (PTO)

The power-takeoff (PTO) switch starts and stops the mower blades and some powered attachments.

1. If the engine is cold, allow the engine to warm up 5 to 10 minutes before engaging the PTO.
2. While seated in the seat, ensure that the traction pedal is in the NEUTRAL position and that the engine is at full throttle.
3. Pull up the PTO switch to engage it (Figure 26).

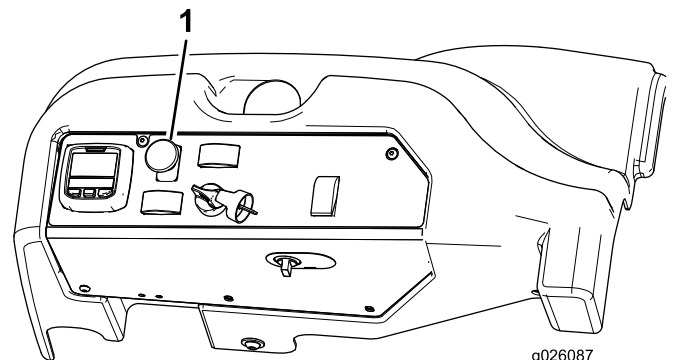

Figure 26

1. PTO switch

Disengaging the PTO

To disengage, push the PTO switch to the OFF position.

Cutting Grass with the Machine

Note: Cutting grass at a rate that loads the engine promotes DPF regeneration.

1. Move the machine to the job site.
2. Whenever possible, set the engine-speed switch to high idle.
3. Engage the PTO switch.
4. Gradually move the traction pedal forward and slowly drive the machine over the mowing area.
5. Once the front of the cutting units are over the mowing area, lower the cutting units.
6. Cut grass so that the blades can cut and discharge clippings at a high rate while producing a good quality of cut.

Note: If the cutting rate is too high, the quality of cut may deteriorate. Reduce the ground speed of the machine or reduce the width of cut to regain high idle engine speed.

7. When the cutting units are over the far edge of the mowing area, lift the cutting units.
8. Perform a tear-shaped turn to quickly line up for your next pass.

Diesel Particulate Filter Regeneration

The diesel particulate filter (DPF) is part of the exhaust system. The diesel-oxidation catalyst of the DPF reduces harmful gasses and the soot filter removes soot from the engine exhaust.

The DPF regeneration process uses heat from the engine exhaust to incinerate the soot accumulated on the soot filter, converting the soot to ash, and clears the channels of the soot filter so that filtered engine exhaust flows out the DPF.

The engine computer monitors the accumulation of soot by measuring the back pressure in the DPF. If the back pressure is too high, soot is not incinerating in the soot filter through normal engine operation. To keep the DPF clear of soot, remember the following:

- Passive regeneration occurs continuously while the engine is running—run the engine at full engine speed when possible to promote DPF regeneration.
- If the back pressure in the DPF is too high or a reset regeneration has not occurred for 100 hours, the engine computer signals you through the InfoCenter when reset regeneration is running.
- Allow the reset regeneration process to complete before shutting off the engine.

Operate and maintain your machine with the function of the DPF in mind. Engine load at high idle (full throttle) engine speed generally produces adequate exhaust temperature for DPF regeneration.

Important: Minimize the amount of time that you idle the engine or operate the engine at low-engine speed to help reduce the accumulation of soot in the soot filter.

DPF Soot Accumulation

- Over time, the diesel particulate filter accumulates soot in the soot filter. The computer for the engine monitors the soot level in the DPF.
- When enough soot accumulates, the computer informs you that it is time to regenerate the DPF.
- DPF regeneration is a process that heats the DPF to convert the soot to ash.
- In addition to the warning messages, the computer reduces the power produced by the engine at different soot-accumulation levels.

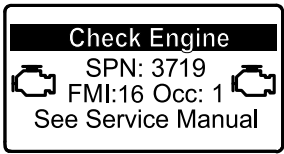
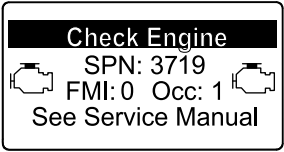

Engine Warning Messages—Soot Accumulation

Indication Level	Fault Code	Engine Power Rating	Recommended Action
Level 1: Engine Warning	 <p style="text-align: center;"><small>g213866</small></p> <p style="text-align: center;">Figure 27 Check Engine SPN 3719, FMI 16</p>	The computer de-rates the engine power to 85%.	Perform a parked regeneration as soon as possible; refer to Performing a Parked or Recovery Regeneration (page 40).
Level 2: Engine Warning	 <p style="text-align: center;"><small>g213867</small></p> <p style="text-align: center;">Figure 28 Check Engine SPN 3719, FMI 0</p>	The computer de-rates the engine power to 50%.	Perform a recovery regeneration as soon as possible; refer to Performing a Parked or Recovery Regeneration (page 40).

DPF Ash Accumulation

- The lighter ash is discharged through the exhaust system; the heavier ash collects in the soot filter.
- Ash is a residue of the regeneration process. Over time, the diesel particulate filter accumulates ash that does not discharge with the engine exhaust.
- The computer for the engine calculates the amount of ash accumulated in the DPF.
- When enough ash accumulates, the engine computer sends information to the InfoCenter in the form of an engine fault to indicate the accumulation of ash in the DPF.
- The fault messages indicate that it is time to service the DPF.
- In addition to the warnings, the computer reduces the power produced by the engine at different ash-accumulation levels.

InfoCenter Advisory and Engine Warning Messages—Ash Accumulation

Indication Level	Fault Code	Engine Speed Reduction	Engine Power Rating	Recommended Action
Level 1: Engine Warning	 <p>g213863</p> <p>Figure 29 Check Engine SPN 3720, FMI 16</p>	None	The computer de-rates the engine power to 85%.	Service the DPF; refer to Servicing the Diesel-Oxidation Catalyst (DOC) and the Soot Filter (page 54)
Level 2: Engine Warning	 <p>g213863</p> <p>Figure 30 Check Engine SPN 3720, FMI 16</p>	None	The computer de-rates the engine power to 50%.	Service the DPF; refer to Servicing the Diesel-Oxidation Catalyst (DOC) and the Soot Filter (page 54)

Types of Diesel Particulate Filter Regeneration

Types of diesel particulate filter regeneration that are performed while the machine is operating:

Type of Regeneration	Conditions that cause DPF regeneration	DPF description of operation
Passive	Occurs during normal operation of the machine at high-engine speed or high-engine load	<ul style="list-style-type: none"> The InfoCenter does not display an icon indicating passive regeneration. During passive regeneration, the DPF processes high-heat exhaust gasses, oxidizing harmful emissions, and burning soot to ash. Refer to Passive DPF Regeneration (page 36) .
Assist	Occurs because of low-engine speed, low-engine load, or after the computer detects the DPF is becoming obstructed with soot	<ul style="list-style-type: none"> The InfoCenter does not display an icon indicating assist regeneration. During assist regeneration, the engine computer adjusts the engine settings to raise the exhaust temperature. Refer to Assist DPF Regeneration (page 37) .
Reset	Occurs every 100 hours Also occurs after assist regeneration only if the computer detects that assist regeneration did not sufficiently reduce the soot level	 <ul style="list-style-type: none"> When the high exhaust-temperature icon is displayed in the InfoCenter, a regeneration is in progress. During reset regeneration, the engine computer adjusts the engine settings to raise the exhaust temperature. Refer to Reset Regeneration (page 37) .

Types of diesel particulate filter regeneration that require you to park the machine:

Type of Regeneration	Conditions that cause DPF regeneration	DPF description of operation
Parked	Occurs because the computer detects back pressure in the DPF due to soot buildup Also occurs because the operator initiates a parked regeneration May occur because you set the InfoCenter to inhibit reset regeneration and continued operating the machine, adding more soot when the DPF already needs a reset regeneration May result from using the incorrect fuel or engine oil	<ul style="list-style-type: none"> When the reset-standby/parked or recovery regeneration icon  or ADVISORY #188 displays in the InfoCenter, a regeneration is requested. Perform the parked regeneration as soon as possible to avoid needing a recovery regeneration. A parked regeneration requires 30 to 60 minutes to complete. You must have at least a 1/4 tank of fuel in the tank. You must park the machine to perform a parked regeneration. Refer to Performing a Parked or Recovery Regeneration (page 40) .

Types of diesel particulate filter regeneration that require you to park the machine: (cont'd.)

Type of Regeneration	Conditions that cause DPF regeneration	DPF description of operation
Recovery	Occurs because the operator ignored requests for a parked regeneration and continued operating the machine, adding more soot to the DPF	<ul style="list-style-type: none"> When the reset-standby/parked or recovery regeneration icon  or ADVISORY #190 displays in the InfoCenter, a recovery regeneration is requested. A recovery regeneration requires up to 3 hours to complete. You must have at least a 1/2 tank of fuel in the machine. You must park the machine to perform a recovery regeneration. <p>Refer to Performing a Parked or Recovery Regeneration (page 40).</p>

Accessing the DPF Regeneration Menus

Accessing the DPF Regeneration Menus

1. Access the Service menu, press the center button to scroll down to the DPF REGENERATION option ([Figure 31](#)).

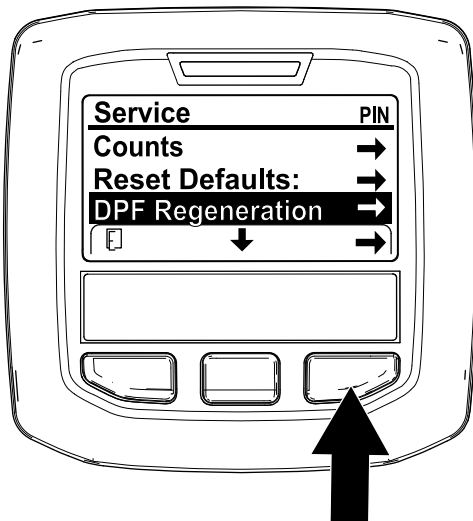

Figure 31

g227667

2. Press the right button to select the DPF Regeneration entry ([Figure 31](#)).

Time Since Last Regeneration

Access the DPF Regeneration menu, press the center button to scroll down to the LAST REGEN field ([Figure 32](#)).

Use the LAST REGEN field to determine how many hours you have run the engine since the last reset, parked, or recovery regeneration.

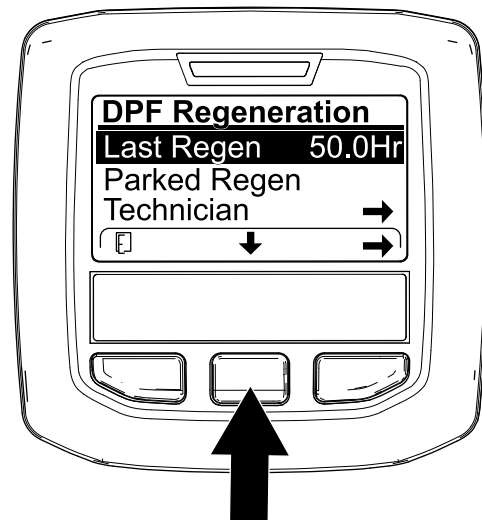

Figure 32

g224693

Technician Menu

Important: For operating convenience, you may decide to perform a parked regeneration before the soot load reaches 100%, provided the engine has run more than 50 hours since the last successful reset, parked, or recovery regeneration.

Use the technician menu to view the current state of engine regeneration control and view the reported soot level.

Access the DPF Regeneration menu, press the center button to scroll down to the TECHNICIAN option, and

press the right button to select the Technician entry (Figure 33).

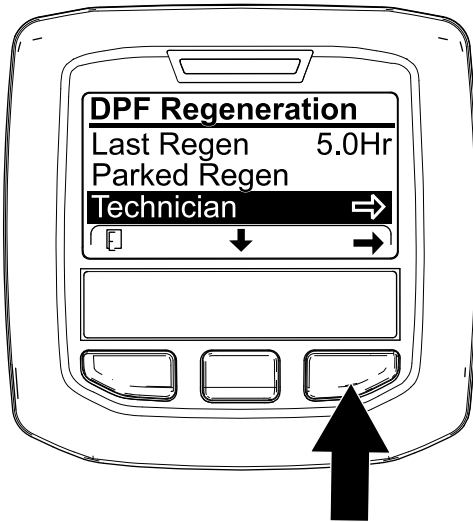

Figure 33

g227348

- Use the DPF operation table to understand the current state of DPF operation (Figure 34).

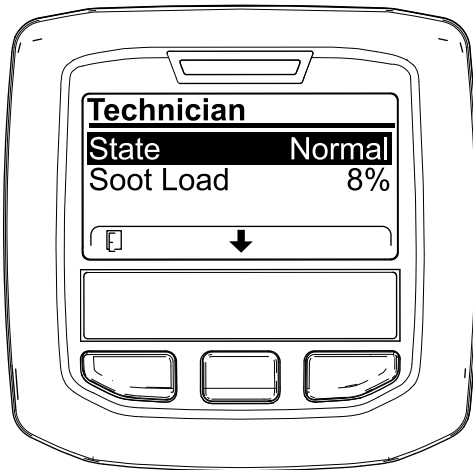

Figure 34

g227360

DPF Operation Table

State	Description	
Normal	The DPF is in normal-operating mode—passive regeneration.	
Assist Regen	The engine computer is performing an assist regeneration.	
Reset Stby	The engine computer is trying to run a reset regeneration, but 1 of the following conditions prevents regeneration:	The regen inhibit setting is set to ON.
		The exhaust temperature is too low for regeneration.

DPF Operation Table (cont'd.)

State	Description
Reset Regen	The engine computer is running a reset regeneration.
Parked Stby	The engine computer is requesting that you run a parked regeneration.
Parked Regen	You initiated a parked regeneration request and the engine computer is processing the regeneration.
Recov. Stby	The engine computer is requesting that you run a recovery regeneration.
Recov. Regen	You initiated a recovery regeneration request and the engine computer is processing the regeneration.

- View the soot load which is measured as the percentage of soot in the DPF (Figure 35); refer to the soot-load table.

Note: The soot load value varies as the machine is operated and DPF regeneration occurs.

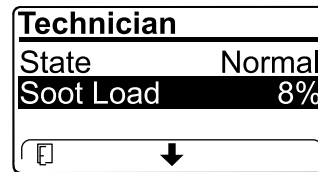

Figure 35

g227359

Soot-Load Table

Important Soot Load Values	Regeneration State
0% to 5%	Minimum soot load range
78%	The engine computer performs an assist regeneration.
100%	The engine computer automatically requests a parked regeneration.
122%	The engine computer automatically requests a recovery regeneration.

Passive DPF Regeneration

- Passive regeneration occurs as part of normal engine operation.
- While operating the machine, run the engine at full-engine speed and high load when possible to promote DPF regeneration.

Assist DPF Regeneration

- The engine computer adjusts engine settings to raise the exhaust temperature.
- While operating the machine, run the engine at full engine speed and high load when possible to promote DPF regeneration.

Reset Regeneration

⚠ CAUTION

The exhaust temperature is hot (approximately 600°C (1,112°F) during DPF regeneration. Hot exhaust gas can harm you or other people.

- Never operate the engine in an enclosed area.
- Make sure that there are no flammable materials around the exhaust system.
- Never touch a hot exhaust system component.
- Never stand near or around the exhaust pipe of the machine.

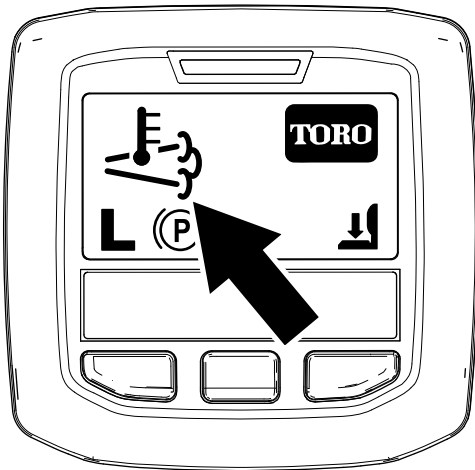



Figure 36

g224417

- The high exhaust-temperature icon  displays in the InfoCenter (Figure 36).
- The engine computer adjusts engine settings to raise the exhaust temperature.

Important: The high exhaust-temperature icon indicates that the exhaust temperature discharged from of your machine may be hotter than during regular operation.

- While operating the machine, run the engine at full engine speed and high load when possible to promote DPF regeneration.

- The icon displays in the InfoCenter while the reset regeneration is processing.
- Whenever possible, do not shut off the engine or reduce engine speed while the reset regeneration is processing.

Important: Whenever possible, allow the machine to complete the reset regeneration process before shutting off the engine.

Periodic Reset Regeneration

If the engine has not completed a successful Reset, Parked, or Recovery regeneration in the previous 100 hours of engine operation, the engine computer will attempt to perform a reset regeneration.

Setting the Inhibit Regen

Reset Regeneration Only

Note: If you set the InfoCenter to inhibit regeneration, the InfoCenter displays ADVISORY #185 (Figure 37) every 15 minutes while the engine requests a reset regeneration.

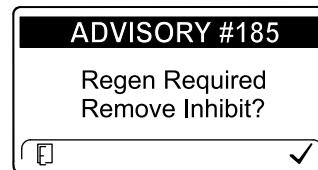

Figure 37

g224692

A reset regeneration produces the elevated engine exhaust. If you are operating the machine around trees, brush, tall grass, or other temperature-sensitive plants or materials, you can use the Inhibit Regen setting to prevent the engine computer from performing a reset regeneration.

Important: When you shut off the engine and start it again, the inhibit regen setting defaults to OFF.

1. Access the DPF Regeneration menu, press the center button to scroll down to the INHIBIT REGEN option, and press the right button to select the Inhibit Regen entry (Figure 38).

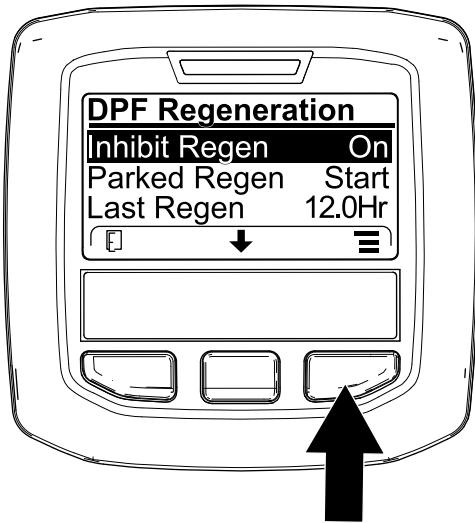

Figure 38

g227304

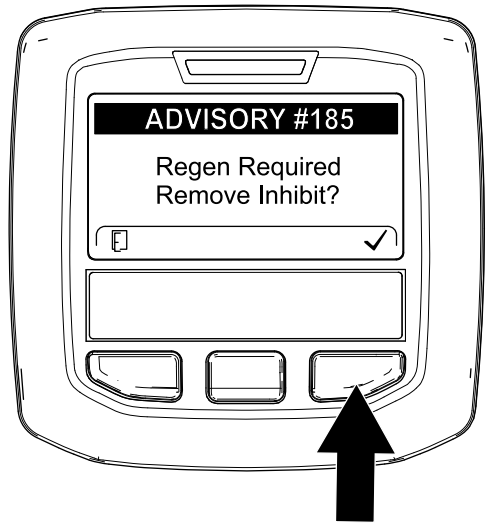

Figure 40

g224394

- Press the right button to change the inhibit regeneration setting from On to Off (Figure 38) or from Off to On (Figure 39).

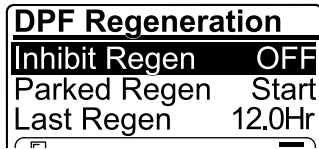

Figure 39

g224691

Note: If the InfoCenter displays ADVISORY #186 (Figure 41), set the engine to full throttle (high idle) to allow the reset regeneration to continue.

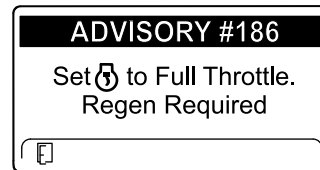



Figure 41

g224395

Allowing a Reset Regeneration

The InfoCenter displays the high exhaust-temperature

icon  when the reset regeneration is in process.

Note: If INHIBIT REGEN is set to ON, the InfoCenter displays ADVISORY #185 (Figure 40). Press button 3 to set inhibit regeneration setting to OFF and continue with the reset regeneration.

Note: When the reset regeneration completes, the

high exhaust-temperature  disappears from the InfoCenter screen.

Parked or Recovery Regeneration

- When the engine computer requests either a parked regeneration or a recovery regeneration, the regeneration request icon (Figure 42) displays in the InfoCenter.

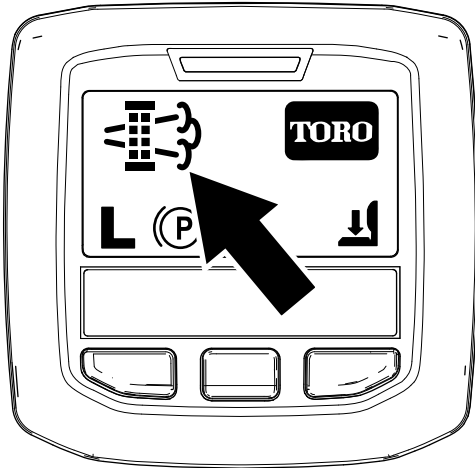

Figure 42

g224404

- The machine does not automatically perform a parked regeneration or a recovery regeneration, you must run the regeneration through the InfoCenter.

Parked Regeneration Messages

When a parked regeneration is requested by the engine computer the following messages display in the InfoCenter:

- Engine warning SPN 3720, FMI 16 (Figure 43)

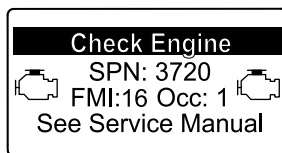

Figure 43

g213863

- Parked regeneration required ADVISORY #188 (Figure 44)

Note: Advisory #188 displays every 15 minutes.

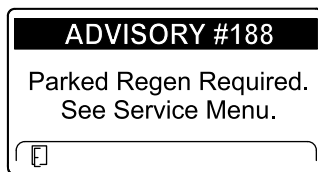

Figure 44

g224397

- If you do not perform a parked regeneration within 2 hours, the InfoCenter displays parked

regeneration required—power takeoff disabled
ADVISORY #189 (Figure 45).

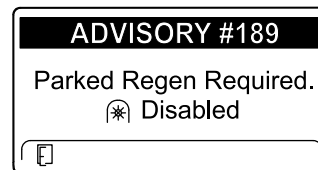

Figure 45

g224398

Important: Perform a parked regeneration to restore the PTO function; refer to [Preparing to Perform a Parked or Recovery Regeneration \(page 40\)](#) and [Performing a Parked or Recovery Regeneration \(page 40\)](#).

Note: The Home screen displays the PTO disabled Icon (Figure 46).

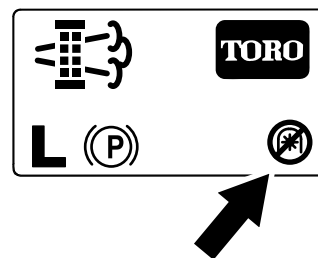

Figure 46

g224415

Recovery Regeneration Messages

When a recovery regeneration is requested by the engine computer, the following messages display in the InfoCenter:

- Engine warning SPN 3719, FMI: 0 (Figure 47)

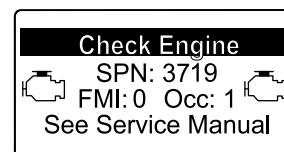

Figure 47

g213867

- Engine warning SPN 522574, FMI: 0 (Figure 48)

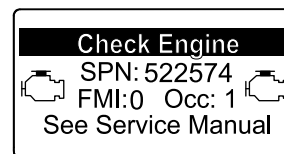

Figure 48

g318159

- Recovery regeneration required—power takeoff disabled ADVISORY #190 (Figure 49)

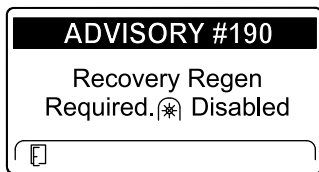

Figure 49

g224399

Important: Perform a recovery regeneration to restore the PTO function; refer to [Preparing to Perform a Parked or Recovery Regeneration \(page 40\)](#) and [Performing a Parked or Recovery Regeneration \(page 40\)](#).

Note: The Home screen displays the PTO disabled icon; refer to [Figure 46 in Parked Regeneration Messages \(page 39\)](#).

DPF Status-Limitation

- If the engine computer requests a recovery regeneration or is processing a recovery regeneration and you scroll down to the PARKED REGEN option, parked regeneration locks and the lock icon ([Figure 50](#)) appears in the lower right corner of the InfoCenter.

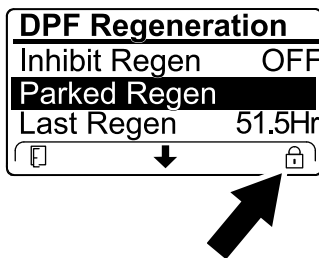

Figure 50

g224625

- If the engine computer has not requested a recovery regeneration and you scroll down to the RECOVERY REGEN option, the recovery regeneration locks and the lock icon ([Figure 51](#)) appears in the lower right corner of the InfoCenter.

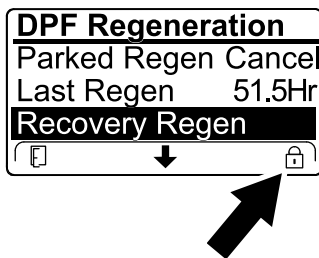

Figure 51

g224628

Preparing to Perform a Parked or Recovery Regeneration

- Ensure that the machine has fuel in the tank for the type of regeneration you are performing:
 - Parked Regeneration:** Ensure that you have 1/4 tank of fuel before performing the parked regeneration.
 - Recovery Regeneration:** Ensure that you have 1/2 tank of fuel before performing the recovery regeneration.
- Move the machine outside to an area away from combustible materials.
- Park the machine on a level surface.
- Ensure that the traction control or motion-control levers are in the NEUTRAL position.
- If applicable, shut off the PTO, and lower the cutting units or accessories.
- Engage the parking brake.
- Set the throttle to the low IDLE position.

Performing a Parked or Recovery Regeneration

⚠ CAUTION

The exhaust temperature is hot (approximately 600°C (1,112°F) during DPF regeneration. Hot exhaust gas can harm you or other people.

- Never operate the engine in an enclosed area.
- Make sure that there are no flammable materials around the exhaust system.
- Never touch a hot exhaust system component.
- Never stand near or around the exhaust pipe of the machine.

Important: The computer of the machine cancels DPF regeneration if you increase the engine speed from low idle or release the parking brake.

- Access the DPF Regeneration menu, press the center button to scroll down to either the PARKED REGEN START option or the RECOVERY REGEN START option ([Figure 52](#)), and press the right button to select the start the regeneration ([Figure 52](#)).

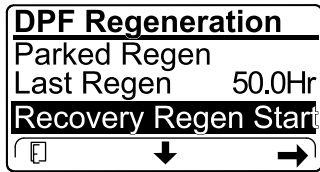
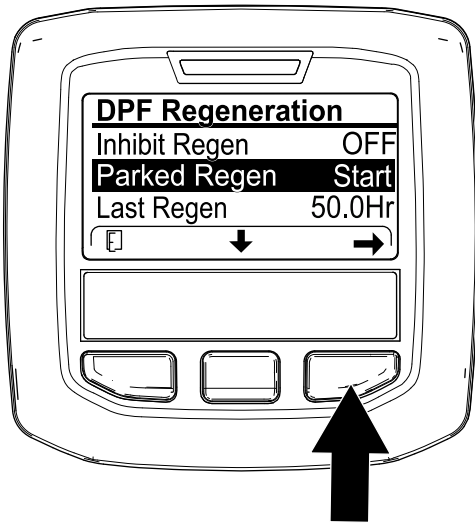

Figure 52

g224402

g224629

- At the DPF checklist screen, verify that the parking brake is engaged and that the engine speed is set to low idle (Figure 54).

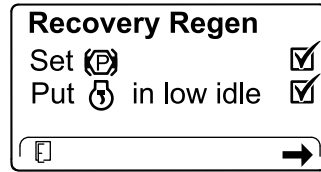
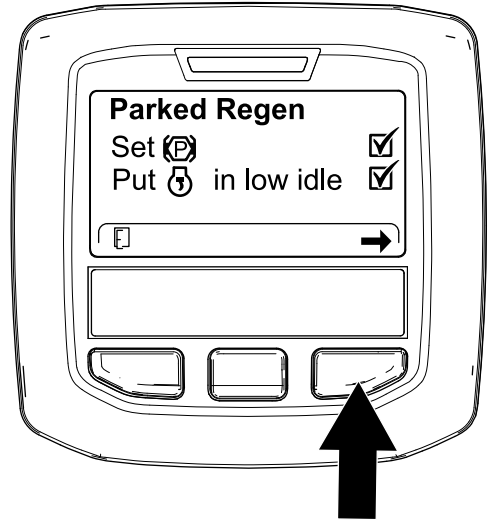

Figure 54

g224407

g227679

- At the VERIFY FUEL LEVEL screen, verify that you have 1/4 tank of fuel if you are performing the parked regeneration or 1/2 tank of fuel if you are performing the recovery regeneration, and press the right button to continue (Figure 53).

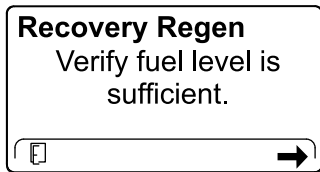
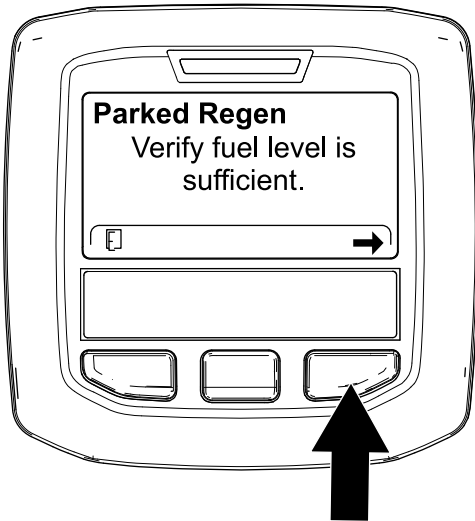

Figure 53

g224414

g227678

- At the INITIATE DPF REGEN screen, press the right button to continue (Figure 55).

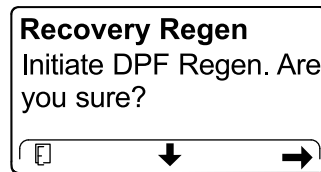
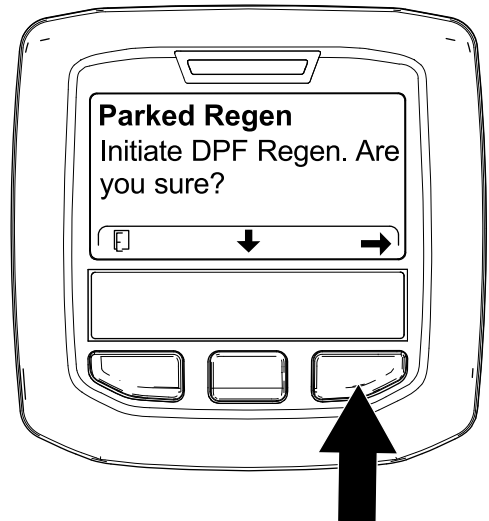
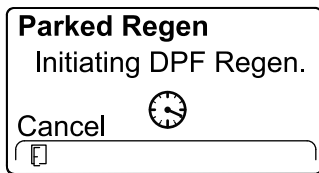

Figure 55

g224626

g224630

5. The InfoCenter displays the INITIATING DPF REGEN message (Figure 56).



g224411

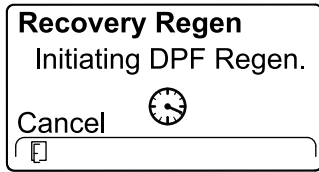

g227681

Figure 56

6. The InfoCenter displays the time to complete message (Figure 57).

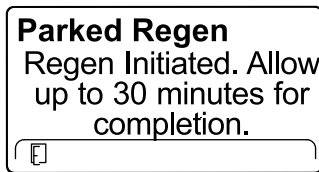

g224406

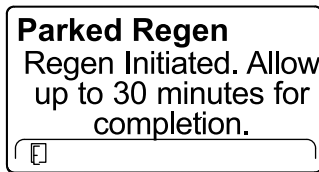

g224406

Figure 57

7. The engine computer checks the engine state and fault information. The InfoCenter may display the following messages found in the table that follows:

Note: If you attempt to do a forced parked regeneration before 50 hours of the last successful regeneration this message will appear. If the machine is requesting a regeneration and this message appears contact your authorized Toro distributor for service.

Check Message and Corrective Action Table

<p>Corrective Action: Exit the regeneration menu and run the machine until the time since last regeneration is greater than 50 hours; refer to Time Since Last Regeneration (page 35).</p>

Check Message and Corrective Action Table (cont'd.)

<p>Corrective Action: Troubleshoot the engine fault and retry DPF regeneration.</p>	
<p>Corrective Action: Start and run the engine.</p>	
<p>Corrective Action: Run the engine to warm the coolant temperature to 60°C (140°F).</p>	
<p>Corrective Action: Change the engine speed to low idle.</p>	
<p>Corrective Action: Troubleshoot the engine computer condition and retry DPF regeneration.</p>	

8. The InfoCenter displays the home screen and the regeneration acknowledge icon (Figure 58) appears in the lower right corner of the screen as the regeneration processes.

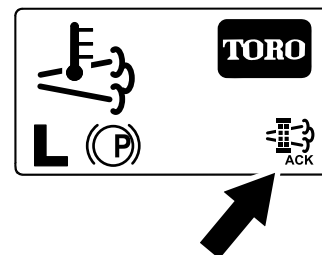



Figure 58

g224403

Note: While the DPF regeneration runs, the InfoCenter displays the high

exhaust-temperature icon .

9. When the engine computer completes a parked or recovery regeneration, the InfoCenter displays ADVISORY #183 (Figure 59). Press the left button to exit to the home screen.



Figure 59

g224392

Note: If the regeneration fails to complete, the InfoCenter displays Advisory #184 (Figure 59). Press the left button to exit to the home screen.

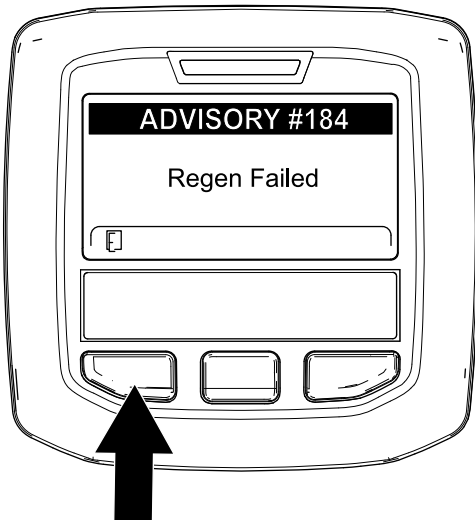

Figure 60

g224393

Canceling a Parked or Recovery Regeneration

Use the Parked Regen Cancel or Recovery Regen Cancel setting to cancel a running parked or recovery regeneration process.

1. Access the DPF Regeneration menu (Figure 61).

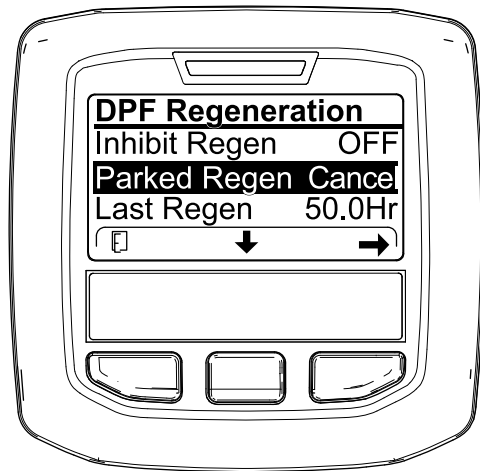

Figure 61

g227305

2. Press the center button to scroll down to the PARKED REGEN CANCEL (Figure 61) or the RECOVERY REGEN CANCEL option (Figure 62).

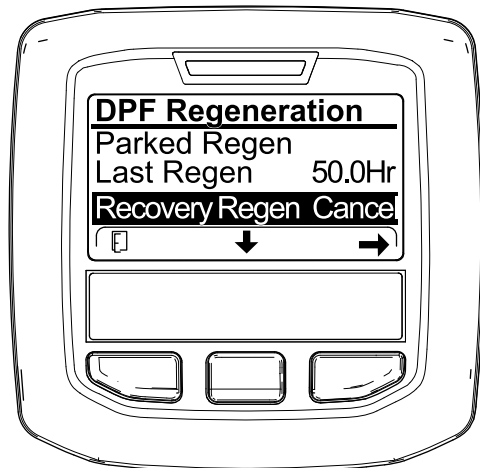

Figure 62

g227306

3. Press the right button to select the Regen Cancel entry (Figure 61 or Figure 62).

Operating Tips

Using the Fast Throttle Setting

To maintain enough power for the machine and deck while mowing, operate the engine at the fast throttle position and adjust your ground speed for conditions.

Selecting the Ground Speed

To improve cut quality, use a slower ground speed. Decrease the ground speed as the load on the cutting blades increases, and increase ground speed as the load on the blades decreases.

Alternating Mowing Direction

Alternate mowing direction to avoid making ruts in the turf over time. This also helps the disperse clippings, which enhances decomposition and fertilization.

Avoiding a Low Cut

If the machine cutting width is wider than the machine that you previously used, raise the cutting height to ensure that uneven turf is not cut too short.

Select the Proper Height-of-Cut Setting to Suit Conditions

Remove approximately 25 mm (1 inch) or no more than 1/3 of the grass blade when cutting. In exceptionally lush and dense grass, you may need to slow down the forward speed and/or raise the height-of-cut to the next higher setting.

Important: If you are cutting more than 1/3 of the grass blade, or are mowing in sparse long grass or dry conditions, use the flat sail of the blades to reduce air-borne chaff, debris, and strain on the deck-drive components.

Cutting Long Grass

If you allow the grass to grow slightly longer than normal, or if the grass contains a high degree of moisture, raise the cutting height to a higher setting and cut the grass at this setting. Then cut the grass again using the lower, normal setting.

Keeping the Mower Clean

Clean clippings and dirt from the underside of the mower after each use. If grass and dirt build up inside the mower, cutting quality eventually becomes unsatisfactory.

To reduce the risk of fire hazard, keep the engine, muffler, battery compartment, parking brake, cutting

units, and fuel storage compartment free of grass, leaves, or excessive grease. Clean up any spilled oil or fuel.

Maintaining the Blades

- Maintain sharp blades throughout the cutting season. Sharp blades create a clean cut without tearing or shredding the grass blades. Tearing and shredding causes grass to turn brown at the edges, which slows growth and increases the chance of disease.
- Check the blades daily for sharpness and for any wear or damage. Sharpen the blades as necessary.
- If a blade is damaged or worn, replace it immediately with a genuine Toro replacement blade. Refer to the cutting unit *Operator's Manual* for instructions to replace the blade.

After Operation

General Safety

- Shut off the engine, remove the key, and wait for all movement to stop before you leave the operator's position. Allow the machine to cool before adjusting, servicing, cleaning, or storing it.
- Clean grass and debris from the cutting units, mufflers, and engine compartment to help prevent fires. Clean up oil or fuel spills.
- If the cutting units are in the transport position, use the positive mechanical lock (if available) before you leave the machine unattended.
- Allow the engine to cool before storing the machine in any enclosure.
- Remove the key and shut off the fuel (if equipped) before storing or hauling the machine.
- Never store the machine or fuel container where there is an open flame, spark, or pilot light, such as on a water heater or on other appliances.
- Maintain and clean the seat belt(s) as necessary

Pushing the Machine by Hand

If the machine stalls or runs out of fuel, you may need to push it. You must first open both of the hydraulic bypass valves.

Important: Always push the machine by hand and never a long distance. Never tow the machine, because damage to the hydraulic system may occur.

Pushing the Machine

1. Disengage the power takeoff (PTO), turn the key to the OFF position, remove the key, and engage the parking brake.
2. Lift the seat.
3. Rotate each bypass valve counterclockwise 1 turn (Figure 63).

Note: This allows hydraulic fluid to bypass the pump, enabling the wheels to turn.

Important: Do not rotate the bypass valves more than 1 turn. This prevents the valves from coming out of the body and causing fluid to run out.

4. Disengage the parking brake before pushing the machine.

Changing to Machine Operation

1. Rotate each bypass valve clockwise 1 turn and hand tighten them (Figure 63).

Note: Do not overtighten the bypass valves.

2. Torque the valves approximately 8 N·m (71 in-lb) as shown in Figure 63.

Note: The machine does not drive unless the bypass valves are turned in.

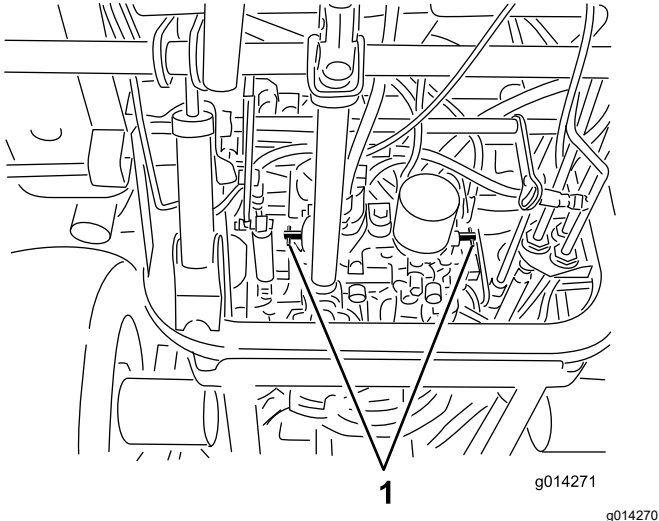

Figure 63

1. Bypass valves

Hauling the Machine

- Remove the key and shut off the fuel (if equipped) before storing or transporting the machine.
- Use care when loading or unloading the machine into a trailer or a truck.

- Use full-width ramps for loading the machine into a trailer or a truck.
- Tie the machine down securely.

Locating the Tie-Down Points

There are tie downs located at the front and rear sides of the machine (Figure 64).

Note: Use properly-rated DOT-approved straps in 4 corners to tie down the machine.

- 2 on the front of the operator's platform
- Rear tire

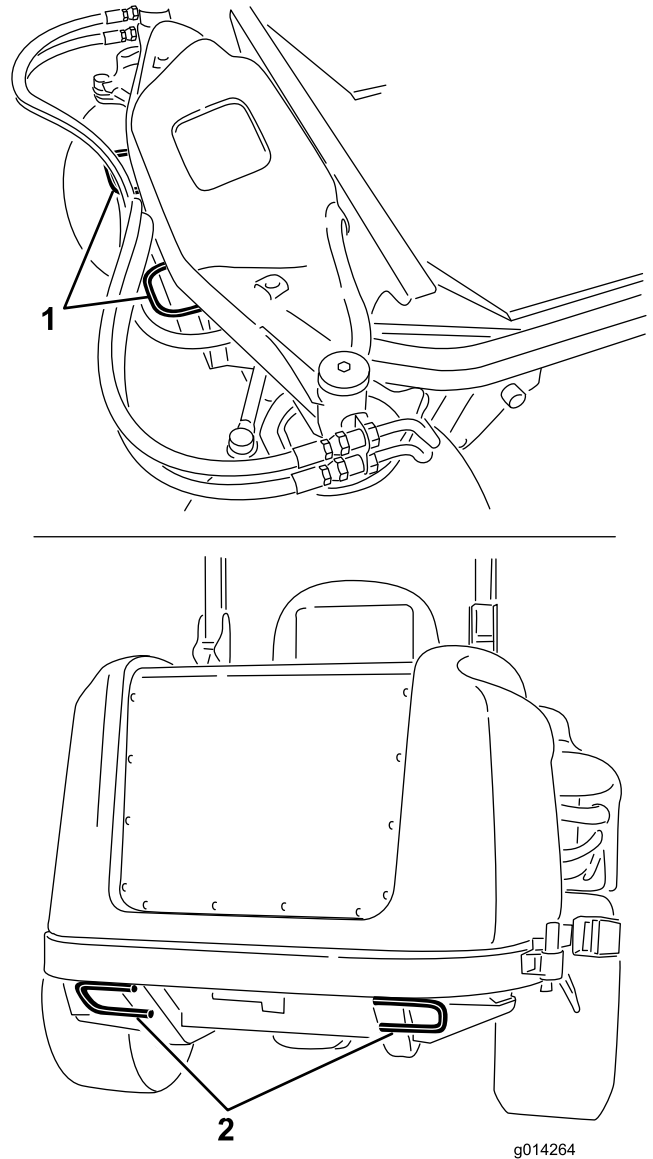

Figure 64

1. Front tie-down point
2. Rear tie-down point

Maintenance

Note: Determine the left and right sides of the machine from the normal operating position.

Download a free copy of the electrical or hydraulic schematic by visiting www.Toro.com and searching for your machine from the Manuals link on the home page.

Maintenance Safety

- Before you leave the operator’s position, do the following:
 - Park the machine on a level surface.
 - Disengage the power takeoff and lower the attachments.
 - Engage the parking brake.
 - Shut off the engine and remove the key.
 - Wait for all movement to stop.
- If you leave the key in the switch, someone could accidentally start the engine and seriously injure you or other bystanders. Remove the key from the switch before you perform any maintenance.
- Allow machine components to cool before performing maintenance.
- If the cutting units are in the transport position, use the positive mechanical lock (if equipped) before you leave the machine unattended.
- If possible, do not perform maintenance while the engine is running. Keep away from moving parts.
- Support the machine with jack stands whenever you work under the machine.
- Carefully release pressure from components with stored energy.
- Keep all parts of the machine in good working condition and all hardware tightened, especially blade-attachment hardware.
- Replace all worn or damaged decals.
- To ensure safe, optimal performance of the machine, use only genuine Toro replacement parts. Replacement parts made by other manufacturers could be dangerous, and such use could void the product warranty.

Recommended Maintenance Schedule(s)

Maintenance Service Interval	Maintenance Procedure
After the first 10 hours	<ul style="list-style-type: none"> • Check the tension of the alternator belt. • Check the belt tension on the air-conditioning compressor. • Torque the wheel-lug nuts.
After the first 200 hours	<ul style="list-style-type: none"> • Change the hydraulic fluid and filter.
Before each use or daily	<ul style="list-style-type: none"> • Test the safety system. • Check the air-cleaner indicator. • Check the engine-oil level. • Drain water or other contaminants from the fuel filter/water separator. • Check the engine-coolant level. • Clean the radiator with compressed air (do not use water). Clean the radiator more frequently in extremely dusty and dirty conditions. • Check the level of the hydraulic fluid. • Clean the machine. • Clean and maintain the seat belt.
Every 50 hours	<ul style="list-style-type: none"> • Grease the bearing and bushing grease fittings. Grease the bearing and bushing grease fittings more frequently in extremely dusty and dirty conditions. • Check battery cable connections. • Check the tire pressure. • Clean the air-conditioning coil. Clean the air-conditioning coil more frequently in extremely dusty or dirty conditions.
Every 100 hours	<ul style="list-style-type: none"> • Check the tension of the alternator belt. • Check the belt tension on the air-conditioning compressor.

Maintenance Service Interval	Maintenance Procedure
Every 200 hours	<ul style="list-style-type: none"> • Inspect the cooling-system hoses and seals. Replace them if they are cracked or torn. • Torque the wheel-lug nuts.
Every 250 hours	<ul style="list-style-type: none"> • Change the engine oil and filter. • Clean the cab air filters; replace them if they are torn or excessively dirty.
Every 400 hours	<ul style="list-style-type: none"> • Service the air cleaner (earlier if the air cleaner indicator shows red, and more frequently in extremely dirty or dusty conditions). • Replace the fuel-filter canister. • Replace the engine fuel filter. • Inspect the fuel lines and connections.
Every 800 hours	<ul style="list-style-type: none"> • Drain and clean the fuel tank. • Change the hydraulic fluid and filter. • Inspect the engine-valve clearance. Refer to your engine owner's manual.
Every 1,500 hours	<ul style="list-style-type: none"> • Replace any moving hoses.
Every 3,000 hours	<ul style="list-style-type: none"> • Disassemble, clean, and assemble the soot filter of the DPF. or clean the soot filter if engine faults SPN 3720 FMI 16 or SPN 3720 FMI 0 display in the InfoCenter.
Before storage	<ul style="list-style-type: none"> • Drain and clean the fuel tank.
Every 2 years	<ul style="list-style-type: none"> • Flush and replace the cooling-system fluid. • Replace moving hoses.

Important: Refer to your engine owner's manual for additional maintenance procedures.

Daily Maintenance Checklist

Duplicate this page for routine use.

Maintenance Check Item	For the week of:						
	Monday	Tuesday	Wednesday	Thursday	Friday	Saturday	Sunday
Check the safety-interlock operation.							
Check the brake operation.							
Check the engine-oil level.							
Check the cooling-system-fluid level.							
Drain the water/fuel separator.							
Check the air filter, dust cup, and burp valve.							
Check for unusual engine noises. ¹							
Check the radiator and screen for debris							
Check for unusual operating noises.							
Check the hydraulic-system-oil level.							
Check the hydraulic hoses for damage.							
Check for fluid leaks.							
Check the fuel level.							
Check the tire pressure.							
Check the instrument operation.							
Check the height-of-cut adjustment.							
Lubricate all the grease fittings. ²							
Touch up any damaged paint.							
Check the air-filter restriction indicator ³							

¹Check the glow plug and injector nozzles if starting is hard, there is excess smoke, or the engine is running rough.

²Immediately **after every** washing, regardless of the interval listed

³If the indicator shows red

Notation for Areas of Concern

Inspection performed by:		
Item	Date	Information

Pre-Maintenance Procedures

⚠ CAUTION

If you leave the key in the key switch, someone could accidentally start the engine and seriously injure you or other bystanders.

Remove the key from the key switch before you do any maintenance.

Using the Hood-Prop Rod

1. Release the hood latches.
2. Lift up the hood until you can position the prop rod behind the frame tube (Figure 65).
3. Lower the hood until the prop rod is in front of and resting against the frame tube.
4. To lower the hood, raise the hood until you can raise the prop rod above the frame tube, then lower the hood.
5. Secure the hood latches.

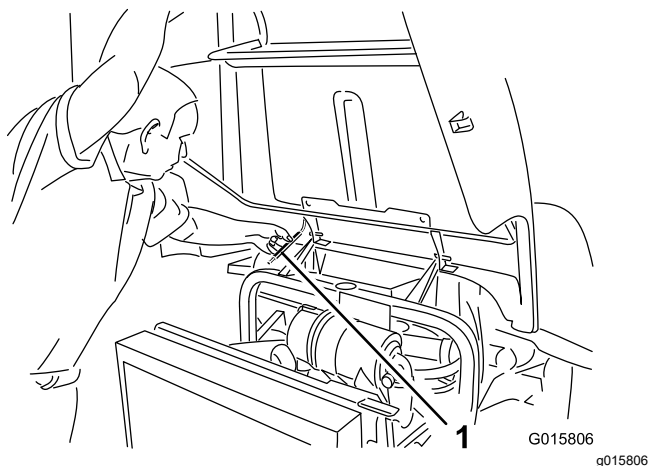

Figure 65

1. Prop rod

Lubrication

Greasing the Bearings and Bushings

Service Interval: Every 50 hours Grease the bearing and bushing grease fittings more frequently in extremely dusty and dirty conditions.

The machine has grease fittings that you must lubricate regularly with No. 2 lithium grease. Lubricate

the grease fittings immediately after every washing, regardless of interval specified.

1. Wipe the grease fittings clean so that foreign matter cannot be forced into the bearing or bushing (Figure 66).
2. Pump the grease into the fittings.
3. Wipe off any excess grease.

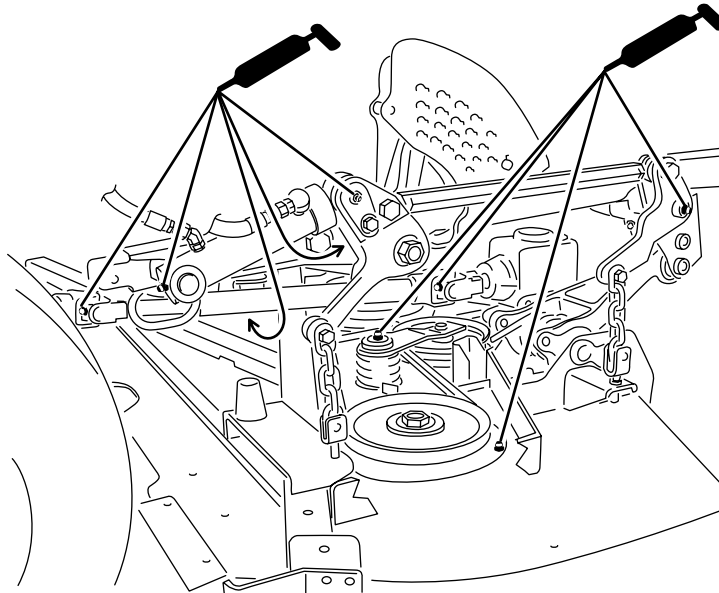

Figure 66
Shown with cutting unit installed

g278285

Note: To access the grease fittings for the rear-steering linkage, remove the storage compartment.

Note: Raise the machine off the floor with a jack and secure it with jack stands to allow better grease

migration through both the upper and lower king-pin bushings. You should see grease purging out of both the top and the bottom of the axle casting/bushing assembly areas of all 4 kingpin assemblies (Figure 67).

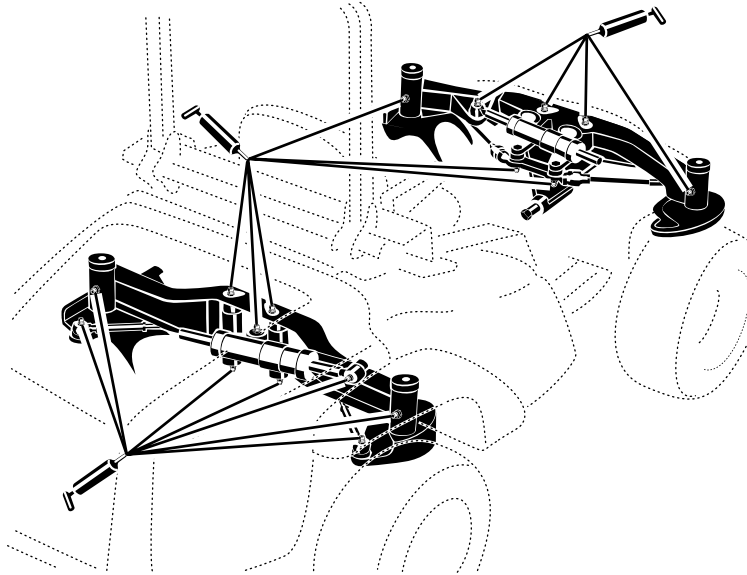

Figure 67

g278286

Note: The bearing life can be negatively affected by improper washing procedures. Do not wash the machine when it is still hot and avoid directing high-pressure or high-volume spray at the bearings or seals.

Engine Maintenance

Engine Safety

- Shut off the engine and remove the key before checking the oil or adding oil to the crankcase.
- Do not change the governor speed or overspeed the engine.

Servicing the Air Cleaner

Service Interval: Before each use or daily—Check the air-cleaner indicator.

Every 400 hours—Service the air cleaner (earlier if the air cleaner indicator shows red, and more frequently in extremely dirty or dusty conditions).

Check the air-cleaner body for damage, which could cause an air leak. Replace it if it is damaged. Check the whole intake system for leaks, damage, or loose hose clamps.

Service the air-cleaner filter only when the service indicator requires it (Figure 68). Changing the air filter before it is necessary only increases the chance of dirt entering the engine when you remove the filter.

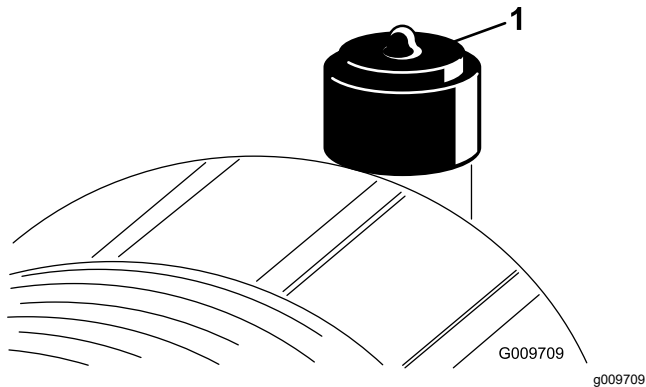

Figure 68

1. Air-cleaner indicator

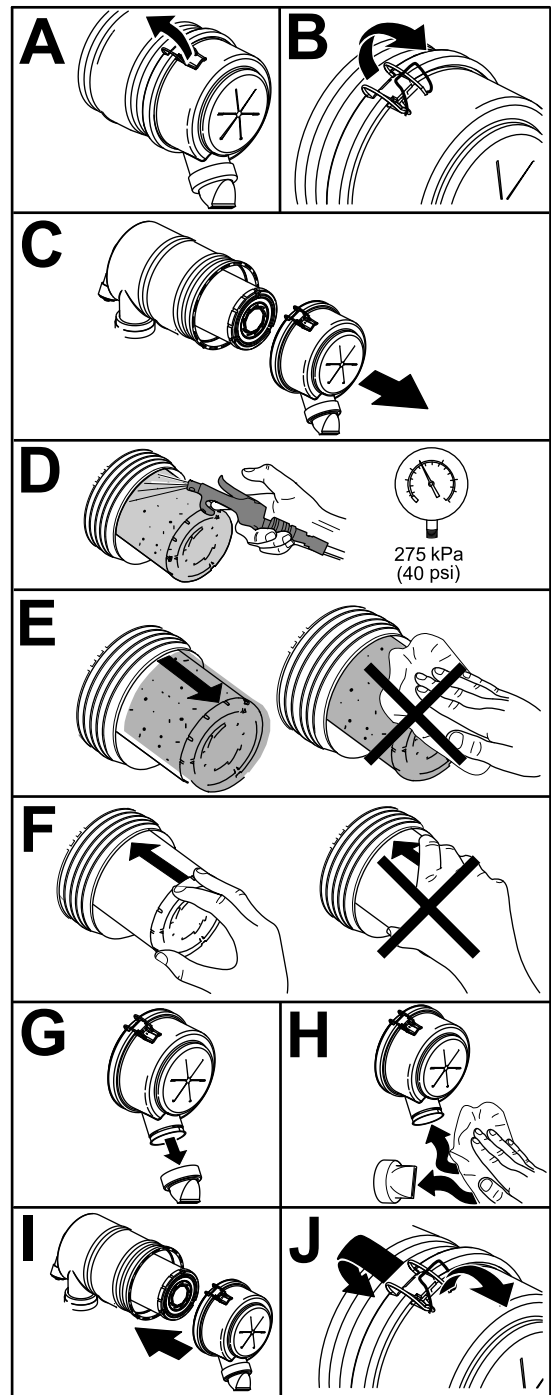

Figure 69

g237806

Important: Be sure that the cover is seated correctly and seals with the air-cleaner body.

1. Replace the air cleaner (Figure 69).

Note: Do not clean the used element due to the possibility of damage to the filter media.

Important: Never attempt to clean the safety filter (Figure 70). Replace the safety filter after every 3 primary filter services.

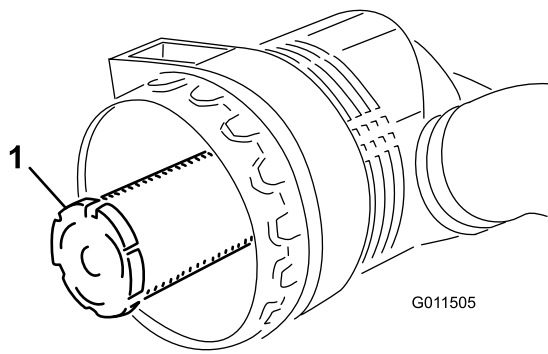

Figure 70

1. Air-cleaner safety filter

2. Reset the indicator (Figure 68) if it shows red.

Servicing the Engine Oil

Oil Specification

Use Toro Premium Engine Oil or another high-quality, low-ash engine oil that meets or exceeds the following specifications:

- API service category CJ-4 or higher
- ACEA service category E6
- JASO service category DH-2

Important: Using engine oil other than API CJ-4 or higher, ACEA E6, or JASO DH-2 may cause the diesel particulate filter to plug or cause engine damage.

Use the following engine oil viscosity grade:

- Preferred oil: SAE 15W-40 (above 0°F)
- Alternate oil: SAE 10W-30 or 5W-30 (all temperatures)

Toro Premium Engine Oil is available from your authorized Toro distributor in either 15W-40 or 10W-30 viscosity grades.

Checking the Engine-Oil Level

Service Interval: Before each use or daily

The engine is shipped with oil in the crankcase; however, the oil level must be checked before and after the engine is first started.

Important: Check the engine oil daily. If the engine-oil level is above the Full mark on the dipstick, the engine oil may be diluted with fuel; If the engine oil level is above the Full mark, change the engine oil.

The best time to check the engine oil is when the engine is cool before it has been started for the day.

If it has already been run, allow the oil to drain back down to the sump for at least 10 minutes before checking. If the oil level is at or below the Add mark on the dipstick, add oil to bring the oil level to the Full mark. **Do not overfill the engine with oil.**

Important: Keep the engine oil level between the upper and lower limits on the dipstick; the engine may fail if you run it with too much or too little oil.

1. Park the machine on a level surface.
2. Check the engine-oil level (Figure 71).

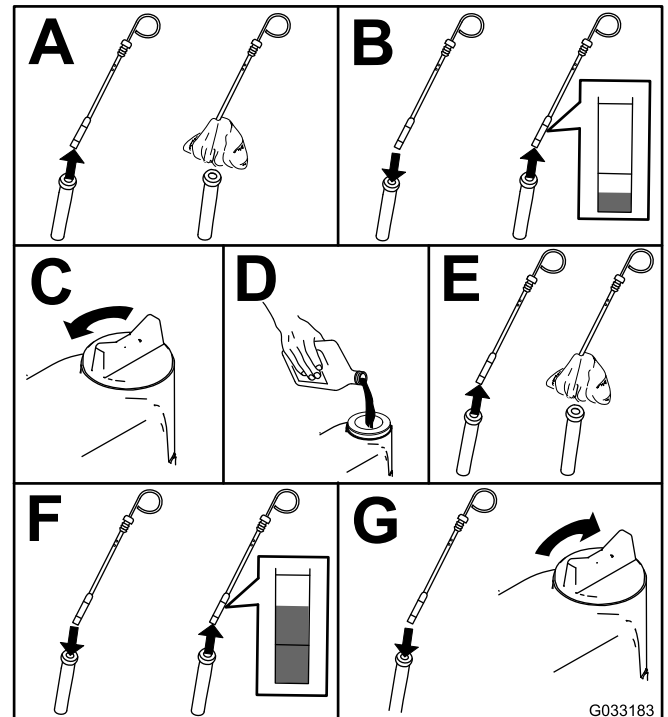

Figure 71

Note: When using different oil, drain all old oil from the crankcase before adding new oil.

Crankcase Oil Capacity

5.2 L (5.5 US qt) with the filter.

Changing the Engine Oil and Filter

Service Interval: Every 250 hours

1. Start the engine and let it run 5 minutes to allow the oil to warm up.
2. Park the machine on a level surface, engage the parking brake, shut off the engine, remove the key.
3. Replace the engine oil and filter (Figure 72).

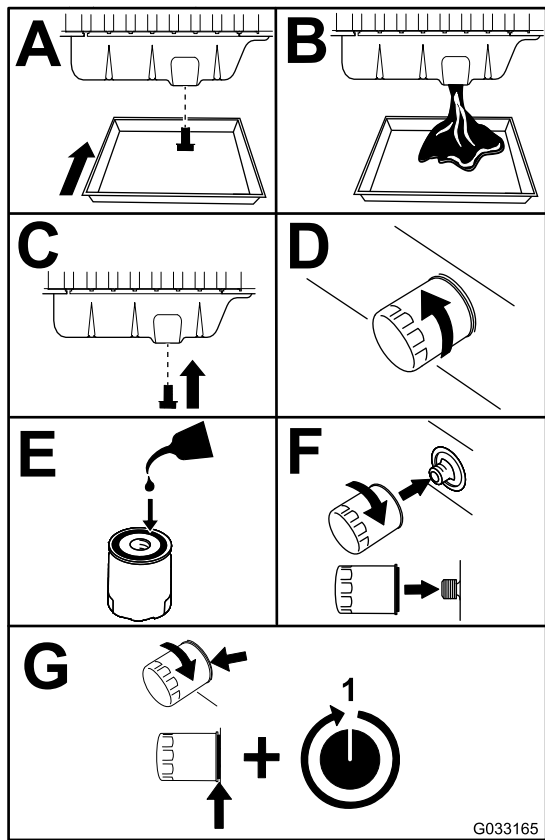
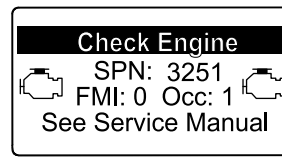
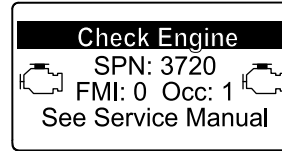

Figure 72

g033165



g214715



g213864

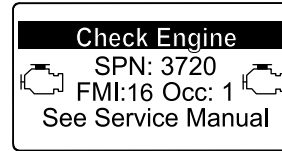

g213863

Figure 73

4. Add oil to the crankcase; refer to [Checking the Engine-Oil Level \(page 53\)](#).

1. Refer to the Engine section in the *Service Manual* for information on disassembling and assembling the diesel-oxidation catalyst and the soot filter of the DPF.
2. Refer to your authorized Toro distributor for diesel-oxidation catalyst and the soot filter replacement parts or service.
3. Contact your authorized Toro distributor to have them reset the engine ECU after you install a clean DPF.

Servicing the Diesel-Oxidation Catalyst (DOC) and the Soot Filter

Service Interval: Every 3,000 hours or clean the soot filter if engine faults SPN 3720 FMI 16 or SPN 3720 FMI 0 display in the InfoCenter.

If engine faults CHECK ENGINE SPN 3251 FMI 0, CHECK ENGINE SPN 3720 FMI 0, or CHECK ENGINE SPN 3720 FMI 16 in the InfoCenter ([Figure 73](#)) display in the InfoCenter, clean the soot filter using the steps that follow:

Fuel System Maintenance

Note: Refer to [Fuel Specification \(page 19\)](#) for the proper fuel recommendations.

⚠ DANGER

Under certain conditions, diesel fuel and fuel vapors are highly flammable and explosive. A fire or explosion from fuel can burn you and others and can cause property damage.

- Use a funnel and fill the fuel tank outdoors, in an open area, when the engine is off and is cold. Wipe up any fuel that spills.
- Do not fill the fuel tank completely full. Add fuel to the fuel tank until the level is to the bottom of the filler neck.
- Never smoke when handling fuel and stay away from an open flame or where a spark may ignite fuel fumes.
- Store fuel in a clean, safety-approved container and keep the cap in place.

Servicing the Water Separator

Service Interval: Before each use or daily—Drain water or other contaminants from the fuel filter/water separator.

Every 400 hours—Replace the fuel-filter canister.

Service the water separator as shown in [Figure 74](#).

After replacing the water separator, turn the key to ON but do not start the engine 3 times for 10 seconds each time.

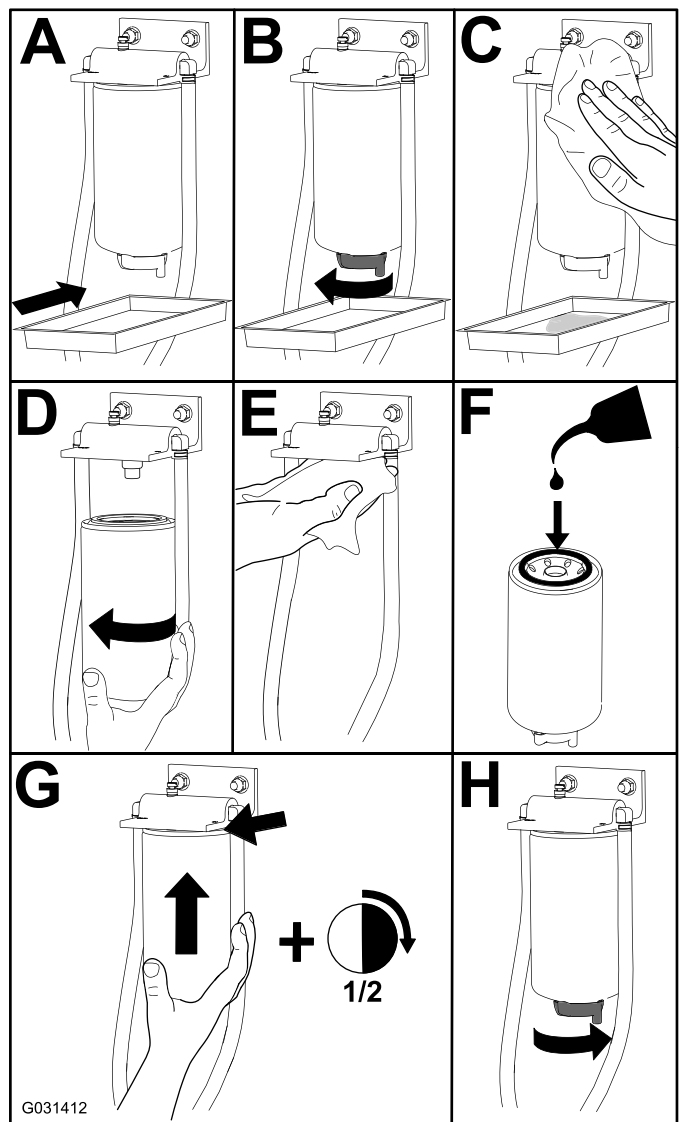

Figure 74

Servicing the Engine Fuel Filter

Service Interval: Every 400 hours

1. Clean the area around the filter head (Figure 75).

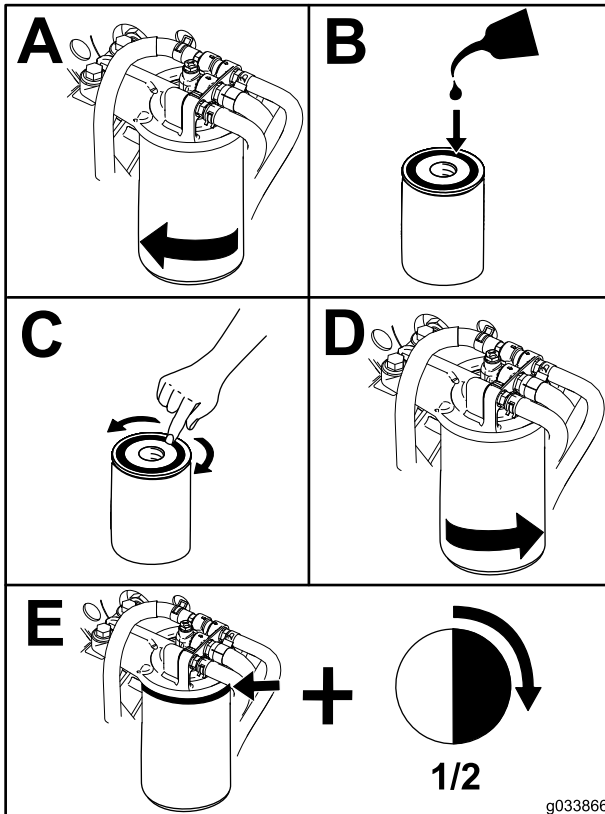

Figure 75

Cleaning the Fuel Pick-Up Tube Screen

The fuel pick-up tube, located inside the fuel tank, is equipped with a screen to help prevent debris from entering the fuel system. Remove the fuel pick-up tube and clean the screen as required.

2. Start the engine and check for fuel leaks around the filter head.

Draining the Fuel Tank

Service Interval: Every 800 hours—Drain and clean the fuel tank.

Before storage—Drain and clean the fuel tank.

In addition to the listed service interval, drain and clean the tank if the fuel system becomes contaminated or if you are storing the machine for an extended period. Use clean fuel to flush out the tank.

Inspecting the Fuel Lines and Connections

Service Interval: Every 400 hours/Yearly (whichever comes first)

Inspect the fuel lines for deterioration, damage, or loose connections.

Electrical System Maintenance

Important: Whenever working with the electrical system, always disconnect the battery cables, negative (-) cable first, to prevent possible wiring damage from short-outs.

Electrical System Safety

- Disconnect the battery before repairing the machine. Disconnect the negative terminal first and the positive last. Connect the positive terminal first and the negative last.
- Charge the battery in an open, well-ventilated area, away from sparks and flames. Unplug the charger before connecting or disconnecting the battery. Wear protective clothing and use insulated tools.

Servicing the Battery

Service Interval: Every 50 hours

Keep the top of the battery clean. If you store the machine in a location where temperatures are extremely high, the battery will run down more rapidly than if the machine is stored in a location where the temperature is cool.

Keep the top of the battery clean by washing it periodically with a brush dipped in ammonia or bicarbonate of soda solution. Flush the top surface with water after cleaning it. Do not remove the fill caps while cleaning the battery.

The battery cables must be tight on the terminals to provide good electrical contact.

If corrosion occurs at the terminals, disconnect the cables, negative (-) cable first, and scrape the clamps and terminals separately. Connect the cables, positive (+) cable first, and coat the terminals with petroleum jelly.

⚠ WARNING

Battery terminals or metal tools could short against metal machine components causing sparks. Sparks can cause the battery gasses to explode, resulting in personal injury.

- When removing or installing the battery, do not allow the battery terminals to touch any metal parts of the machine.
- Do not allow metal tools to short between the battery terminals and metal parts of the machine.

⚠ WARNING

Incorrect battery cable routing could damage the machine and cables causing sparks. Sparks can cause the battery gasses to explode, resulting in personal injury.

- Always disconnect the negative (black) battery cable before disconnecting the positive (red) cable.
- Always connect the positive (red) battery cable before connecting the negative (black) cable.

Checking the Fuses

If the machine stops or has other electrical-system issues, check the fuses. Grasp each fuse in turn and remove them 1 at a time, checking to see if any are blown. If you need to replace a fuse, always use the **same type and amperage rated fuse** as the 1 you are replacing; **otherwise, you could damage the electrical system** (refer to the decal next to the fuses for a diagram of each fuse and its amperage).

Tilt the seat forward, and pull the panel off to access the fuses (Figure 76).

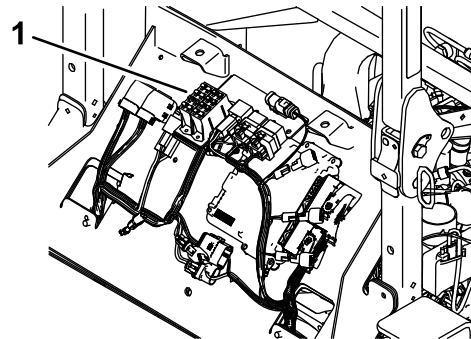

Figure 76

g198812

1. Fuse block

The fuse block for attachments are located under the seat (Figure 77).

Drive System Maintenance

Checking the Tire Pressure

Service Interval: Every 50 hours

Maintain the air pressure in the front and rear tires. The correct air pressure is 172 kPa (25 psi) in the rear tires and 103 kPa (15 psi) in the front tires. If a cab is installed on the machine, the front and rear tires should be inflated to 172 kPa (25 psi). Uneven tire pressure can cause an uneven cut. Check the tires when they are cold to get the most accurate pressure reading.

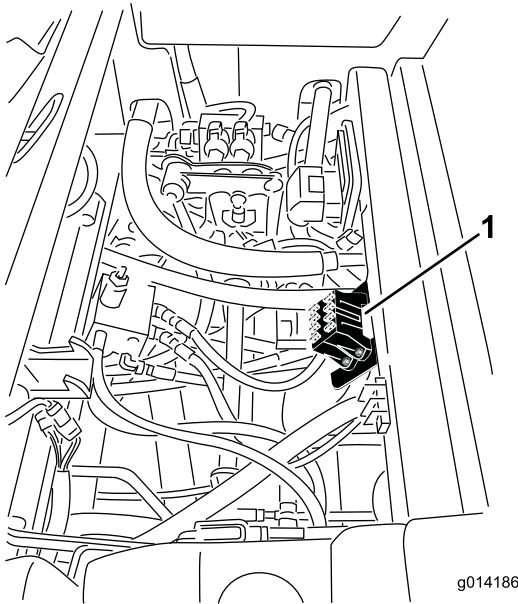

Figure 77

1. Location of the fuse block

The cab fuses are located in the fuse box on the cab headliner (Figure 78).

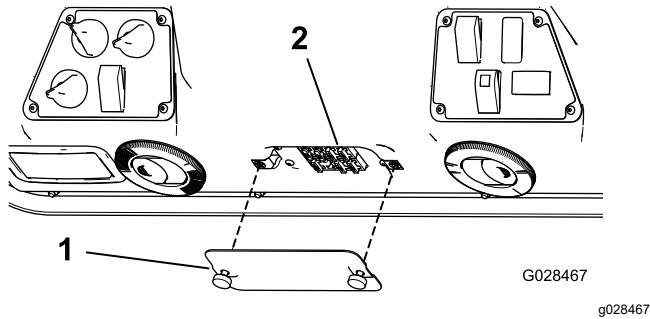

Figure 78

1. Cover
2. Fuses

Storing the Battery

If you store the machine for more than 30 days, remove the battery and charge it fully. Either store it on a shelf or on the machine. Leave the cables disconnected if you store it on the machine. Store the battery in a cool atmosphere to avoid quick deterioration of the charge in the battery. To prevent the battery from freezing, ensure that it is fully charged. The specific gravity of a fully charged battery is 1.265 to 1.299.

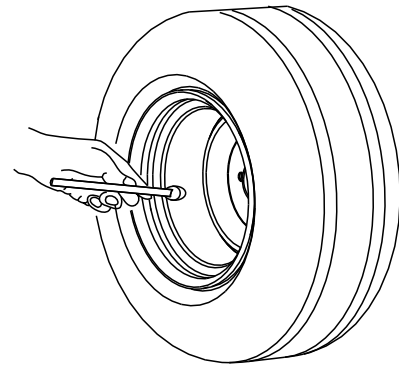

Figure 79

Correcting the Steering Misalignment

1. Press the steering-selector switch rearward 4-wheels steering position (Figure 80).

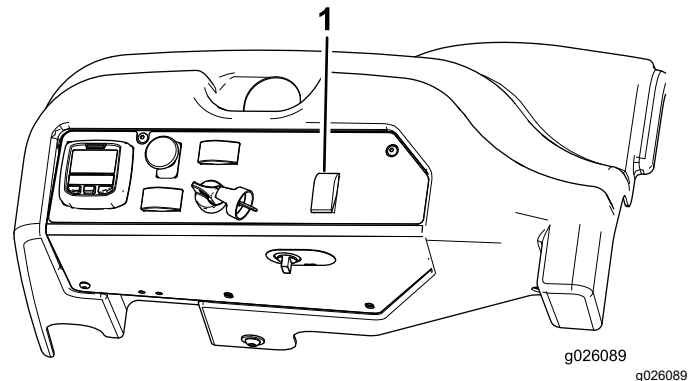

Figure 80

1. Steering-selector switch
2. On a paved or dirt surface, turn the steering wheel to the left or right and continue turning until all 4 wheels have stopped turning. Automatic

synchronization of the wheel alignment should occur.

Important: Doing this procedure on turf can result in turf damage directly under each of the turning tires.

Cooling System Maintenance

Cooling System Safety

- Swallowing engine coolant can cause poisoning; keep out of reach from children and pets.
- Discharge of hot, pressurized coolant or touching a hot radiator and surrounding parts can cause severe burns.
 - Always allow the engine to cool at least 15 minutes before removing the radiator cap.
 - Use a rag when opening the radiator cap, and open the cap slowly to allow steam to escape.
- Do not operate the machine without the covers in place.
- Keep your fingers, hands and clothing clear of rotating fan and drive belt.

Coolant Specification

The coolant reservoir is filled at the factory with a 50/50 solution of water and ethylene glycol base extended-life coolant.

Important: Use only commercially available coolants that meet the specifications listed in the Extended Life Coolant Standards Table.

Do not use conventional (green) inorganic-acid technology (IAT) coolant in your machine. Do not mix conventional coolant with extended-life coolant.

Coolant Type Table

Ethylene-Glycol Coolant Type	Corrosion Inhibitor Type
Extended-life antifreeze	Organic-acid technology (OAT)

Important: Do not rely on the color of the coolant to identify the difference between conventional (green) inorganic-acid technology (IAT) coolant and extended-life coolant.

Coolant manufacturers may dye extended-life coolant in one of the following colors: red, pink, orange, yellow, blue, teal, violet, and green. Use coolant that meets the specifications in the Extended Life Coolant Standards Table.

Extended Life Coolant Standards

ATSM International	SAE International
D3306 and D4985	J1034, J814, and 1941

Important: Coolant concentration should be a 50/50 mixture of coolant to water.

- **Preferred:** When mixing coolant from a concentrate, mix it with distilled water.
- **Preferred option:** If distilled water is not available, use a pre-mix coolant instead of a concentrate.
- **Minimum requirement:** If distilled water and pre-mix coolant are not available, mix concentrated coolant with clean drinkable water.

Checking the Cooling System

Service Interval: Before each use or daily

The cooling system is filled with a 50/50 solution of water and permanent ethylene glycol anti freeze. Check the level of the coolant in the expansion tank at the beginning of each day before starting the engine. The capacity of the cooling system is 7.5 L (6 US qt).

1. Check the level of the coolant in the expansion tank (Figure 81). The coolant level should be between the marks on the side of the tank.
2. If coolant level is low, remove the expansion tank cap and replenish the system. **Do not overfill.**
3. Install the expansion-tank cap.

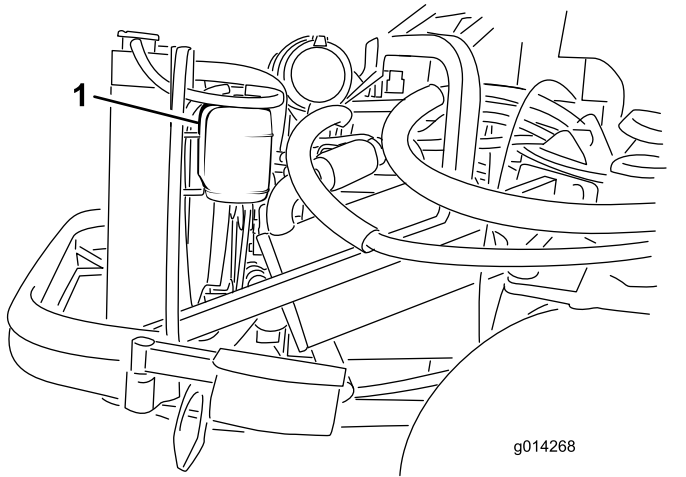

Figure 81

1. Expansion tank

Cleaning the Radiator

Service Interval: Before each use or daily Clean the radiator more frequently in extremely dusty and dirty conditions.

Keep the radiator clean to prevent the engine from overheating.

Note: If the attachment or engine shuts off due to overheating, first check the radiator for an excessive buildup of debris.

1. Open the hood and secure the prop rod.
2. Loosen the flange nut securing the clean-out cover to the underside of the rear frame (Figure 82). Rotate the cover to the side to expose the clean-out hole in the frame.

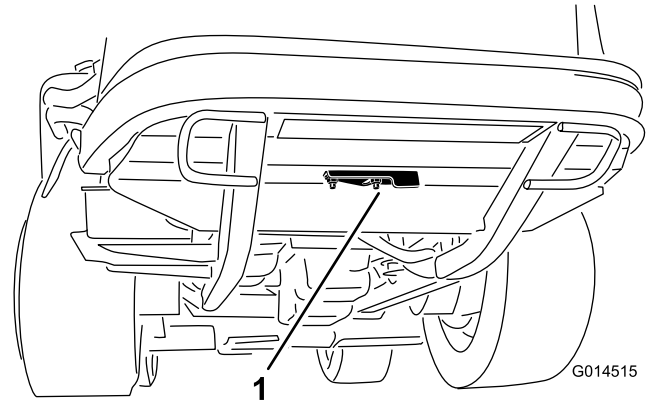

Figure 82

1. Clean-out cover
-
3. Working from the fan side of the radiator, blow out debris with low-pressure (50 psi) compressed air (**do not use water**). Repeat this step from the front of the radiator, again from the fan side.
 4. After you have thoroughly cleaned the radiator, remove any debris from the channel at the radiator base and around the frame.
 5. Clean the engine compartment and the brake linkage.
 6. Close the clean-out cover and secure the flange nut.
 7. Close the hood.

Brake Maintenance

Adjusting the Brakes

Adjust the service brakes when there is more than 25 mm (1 inch) of free travel of the brake pedal, or when the brakes do not work effectively. Free travel is the distance that the brake pedal moves before you feel braking resistance.

Note: Use the wheel-motor backlash to rock the drums back and forth to ensure that the drums are free prior to and after adjustment.

1. To reduce free travel of the brake pedals, tighten the brakes by loosening the front nut on the threaded end of the brake cable (Figure 83).

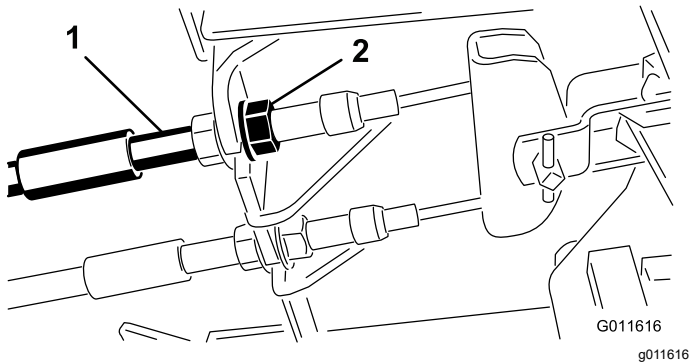

Figure 83

1. Brake cables
2. Front nuts

2. Tighten the rear nut to move the cable backward until brake pedals have 1.27 to 1.9 cm (1/2 to 3/4 inch) of free travel before the wheels lock up.
3. Tighten the front nuts, ensuring that both cables actuate the brakes simultaneously.

Adjusting the Parking Brake

If the parking brake fails to engage, adjust the brake pawl.

1. Loosen the 2 screws securing the parking-brake pawl to the frame (Figure 84).

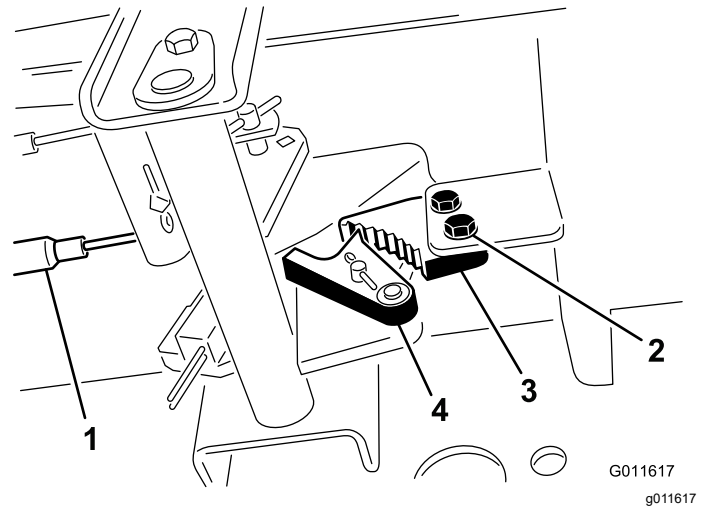

Figure 84

1. Brake cables
2. Screws (2)
3. Parking-brake pawl
4. Brake detent

2. Press the parking brake pedal forward until the brake detent completely engages on the brake pawl (Figure 84).
3. Tighten the 2 screws locking the adjustment.
4. Press the brake pedal to release the parking brake.
5. Check the adjustment and adjust it as required.

Belt Maintenance

Checking the Alternator Belt

Service Interval: After the first 10 hours

Every 100 hours

1. Ensure that the proper tension allows 10 mm (3/8 inch) deflection when a force of 4.4 kg (10 lb) is applied on the belt midway between the pulleys.
2. If the deflection is not 10 mm (3/8 inch), loosen the alternator mounting bolts (Figure 85). Increase or decrease the tension of the alternator belt and tighten the bolts. Check the deflection of the belt again to ensure that the tension is correct.

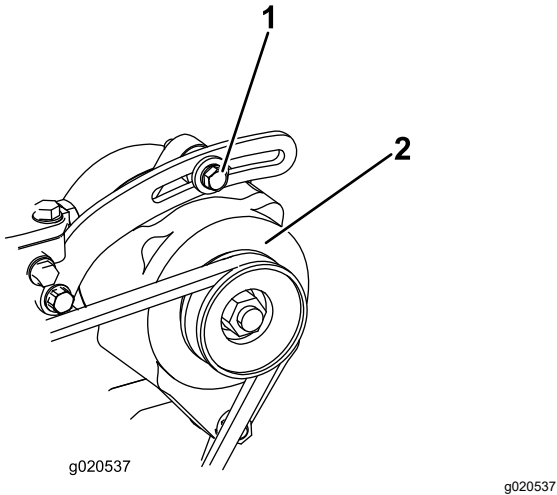

Figure 85

1. Mounting bolt
2. Alternator

Controls System Maintenance

Adjusting the Traction Drive for Neutral

Note: If the machine has recently had the hydraulic fluid changed or the traction motors or hoses replaced, work out any air trapped in the system prior to performing this procedure. To do this, operate the machine in forward and reverse for a few minutes and then replenish the oil as required.

Note: When positioned on a level surface, the machine must not creep when you release the traction pedal.

1. Park the machine on a level surface, engage the parking brake, lower the cutting unit to the floor, and shut off the engine.
2. Jack up the rear of the machine until the rear tires are off the shop floor. Support the machine with jack stands to prevent it from falling.

Note: On 4-wheel-drive models, the front tires must also be off the shop floor and supported by jack stands.

▲ WARNING

The engine must be running so that you can perform this adjustment. This could cause personal injury.

Keep your hands, feet, face, and other body parts away from any hot parts of the engine and any rotating parts.

3. Start the engine, set the throttle to the SLOW position, and observe which direction the rear tires rotate.

Important: Make sure that the traction pedal is in the NEUTRAL position.

- If the left rear tire is rotating, loosen the jam nuts on the left side transmission control rod (Figure 86).

Note: The forward end of the control rod has a left-hand thread. The rear end of the rod, which is connected to the transmission, has a right-hand thread.

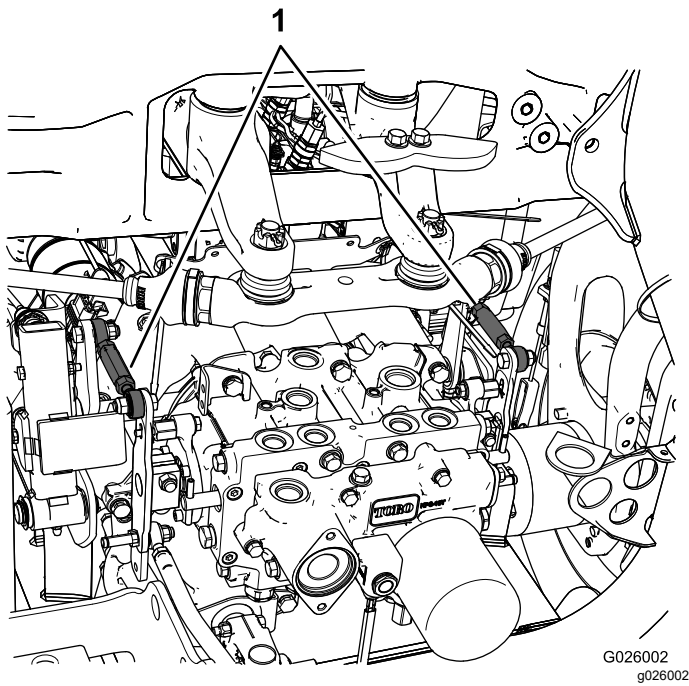

Figure 86

1. Transmission control rods

- If the left rear tire is rotating in reverse, lengthen the rod by slowly turning the rod counterclockwise (as viewed from the front) until the left rear tire stops rotating or has minimal rotation in reverse.
 - If the left rear tire is rotating forward, shorten the rod by slowly turning the rod clockwise (as viewed from the front) until the left rear tire stops rotating.
4. Move the throttle to the FAST position. Make sure that the wheel remains stopped or has minimal rotation in reverse. Adjust it as required.
 5. Tighten the jam nuts.
 6. Repeat the procedure for the right rear tire, if required, by using the right-side transmission control rod.
 7. Shut off the engine, remove the jack stands, and lower the machine to the shop floor.
 8. Test drive the machine to make sure that it does not creep.

Adjusting the Maximum Ground Speed

1. Park the machine on a level surface, disengage the PTO, release the traction pedal to the NEUTRAL position, and engage the parking brake.
2. Move the throttle lever to the SLOW position, shut off the engine, remove the key, and wait

for all moving parts to stop before leaving the operating position.

3. Loosen the jam nut on the stop bolt for the traction pedal (Figure 87).

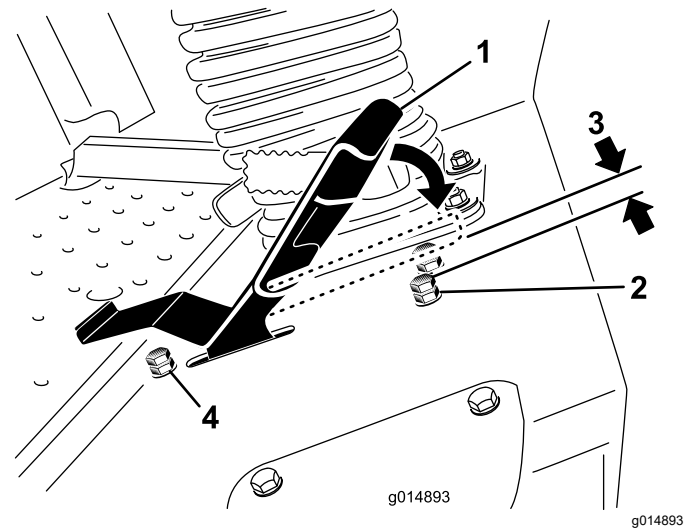

Figure 87

- | | |
|-------------------------------------|-------------------------------------|
| 1. Traction pedal | 3. 1.5 mm (0.060 inch) |
| 2. Stop bolt with jam nut (forward) | 4. Stop bolt with jam nut (reverse) |

4. Adjust the stop bolt all the way in (away from the traction pedal).
5. Using your hand, push the traction pedal all the way forward, with light pressure, until it stops and hold it there.

Note: Maintain only light pressure on the pedal when pushing it to the full forward position.
6. With the seat in the raised position, verify that you are not over loading the linkage by making sure the transmission does not move when you press the pedal to the stop.
7. Adjust the stop bolt out (toward the traction pedal) until there is a gap of 1.5 mm (0.060 inch) between the head of the stop bolt and the bottom of the traction pedal.
8. Tighten the jam nut to secure the stop bolt in place.
9. To change the reverse speed, you can adjust the reverse stop bolt. To increase the reverse speed, adjust the stop bolt in; to decrease the reverse speed, adjust the stop bolt out.

Hydraulic System Maintenance

Hydraulic System Safety

- Seek immediate medical attention if fluid is injected into skin. Injected fluid must be surgically removed within a few hours by a doctor.
- Ensure that all hydraulic-fluid hoses and lines are in good condition and all hydraulic connections and fittings are tight before applying pressure to the hydraulic system.
- Keep your body and hands away from pinhole leaks or nozzles that eject high-pressure hydraulic fluid.
- Use cardboard or paper to find hydraulic leaks.
- Safely relieve all pressure in the hydraulic system before performing any work on the hydraulic system.

Hydraulic Fluid Specification

The reservoir is filled at the factory with high-quality tractor transmission/hydraulic fluid. The recommended replacement fluid is as follows:

Toro Premium Transmission/Hydraulic Tractor Fluid (Available in 19 L (5 gallon) pails or 208 L (55 gallon) drums. See the *Parts Catalog* or your Toro Distributor for part numbers).

Alternate fluids: If the Toro fluid is not available, Mobil® 424 hydraulic fluid may be used.

Note: Toro will not assume responsibility for damage caused by improper substitutions.

Many hydraulic fluids are almost colorless, making it difficult to spot leaks. A red dye additive for the hydraulic system oil is available in 20 ml (2/3 fl oz) bottles. One bottle is sufficient for 15 to 22 L (4 to 6 US gallons) of hydraulic fluid. Order Part No. 44-2500 from your authorized Toro distributor.

Checking the Hydraulic System

Service Interval: Before each use or daily

1. Park the machine on a level surface, release the traction pedal to the NEUTRAL position, and start the engine.
2. Run the engine at the lowest possible speed to purge the system of air.

Important: Do not engage the PTO.

3. Raise the deck to extend the lift cylinders, shut off the engine, and remove the key.
4. Remove the hydraulic-filler cap (Figure 88) from the filler neck.
5. Remove the dipstick and wipe it with a clean rag (Figure 88).
6. Screw the dipstick all the way into the filler neck; then remove it, and check the level of the fluid (Figure 88).

If the level is not within the notched area of the dipstick, add enough high-quality hydraulic fluid to raise the level to within the notched area. **Do not overfill the hydraulic system.**

7. Replace the dipstick and thread the fill cap finger-tight onto the filler neck.
8. Check all hoses and fittings for leaks.

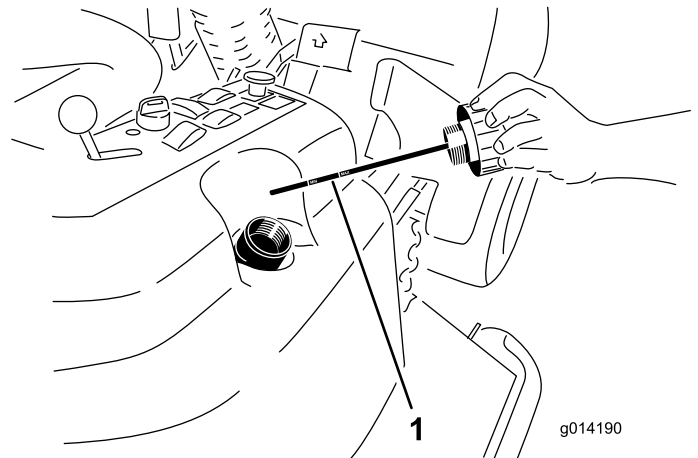

Figure 88

1. Dipstick

Changing the Hydraulic Fluid And Filter

Service Interval: After the first 200 hours

Every 800 hours

Hydraulic reservoir capacity: approximately 17 L (18 US qt)

1. Disengage the PTO, release the traction pedal to the NEUTRAL position, and engage the parking brake.
2. Move the throttle lever to the SLOW position, shut off the engine, remove the key, and wait for all moving parts to stop before leaving the operating position.

- Place a large pan under the hydraulic reservoir and transmission case and remove the plugs, draining all of the hydraulic fluid ([Figure 89](#)).

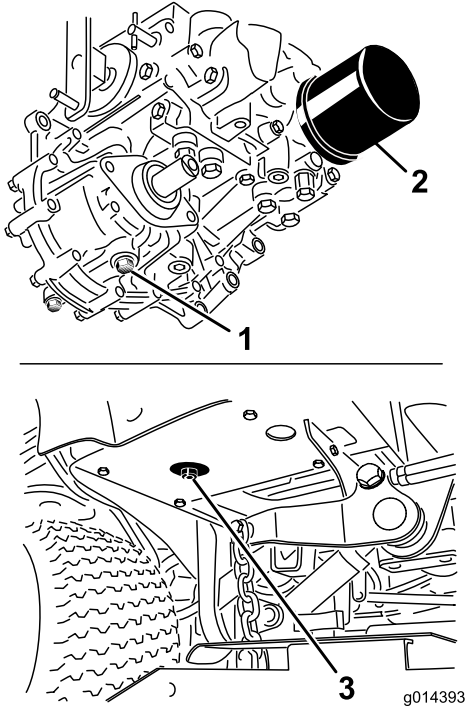

Figure 89

- | | |
|---------------------------------|-----------------------------------|
| 1. Transmission-case drain plug | 3. Hydraulic-reservoir drain plug |
| 2. Filter | |

- Clean the area around the hydraulic-fluid filter and remove the filter ([Figure 89](#)).
- Immediately install a new hydraulic-fluid filter.
- Install the drain plugs in the hydraulic reservoir and the transmission case.
- Fill the reservoir to the proper level; refer to [Checking the Hydraulic System \(page 64\)](#).
- Start the engine and check for fluid leaks. Allow the engine to run for about 5 minutes, then shut it off.
- After 2 minutes, check the level of the hydraulic fluid; refer to [Checking the Hydraulic System \(page 64\)](#).

Cab Maintenance

Filling the Washer-Fluid Bottle

- Perform the pre-maintenance procedure; refer to [Maintenance Safety \(page 46\)](#).
- Open the hood and locate the washer-fluid bottle ([Figure 90](#)).

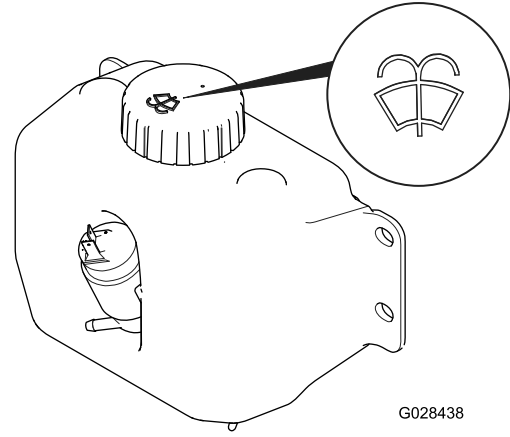

Figure 90

Washer-Fluid Bottle with Washer-Fluid Symbol

- Fill the bottle with washer fluid as needed.
- Close the hood.

Cleaning the Cab Air Filters

Service Interval: Every 250 hours

1. Remove the screws and grates from both the in-cab and rear cab air filters (Figure 91 and Figure 92).

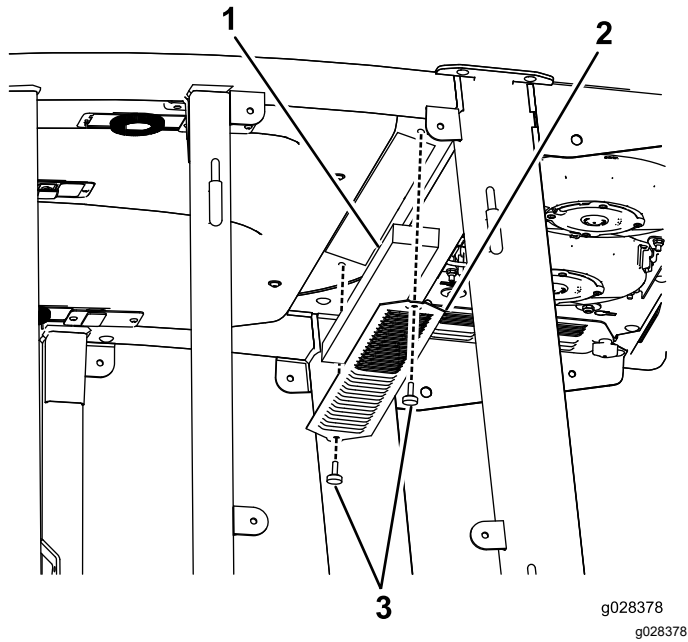

Figure 91
In-Cab Air Filter

- | | |
|-----------|----------|
| 1. Filter | 3. Screw |
| 2. Grate | |

Important: If either filter has a hole, tear, or other damage, replace the filter.

3. Install the filters and the grate with the thumbscrews.

Cleaning the Air-Conditioning Coil

Service Interval: Every 50 hours Clean the air-conditioning coil more frequently in extremely dusty or dirty conditions.

1. Perform the pre-maintenance procedure; refer to [Maintenance Safety \(page 46\)](#).
2. Lift the 4 tabs on the air-conditioning screen (Figure 93) and remove the screen from the top of the cab.

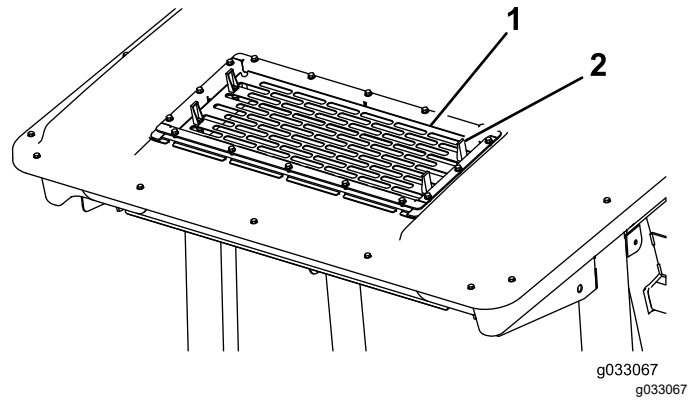

Figure 93

- | | |
|-----------|------------|
| 1. Screen | 2. Tab (4) |
|-----------|------------|

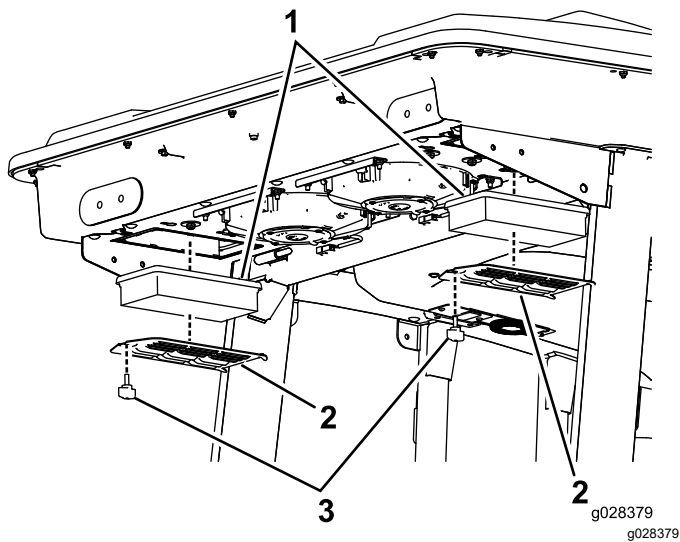

Figure 92
Rear Cab Air Filter

- | | |
|-----------|----------|
| 1. Filter | 3. Screw |
| 2. Grate | |

3. Disconnect the plug and cord for the fans from the outlet (Figure 94).

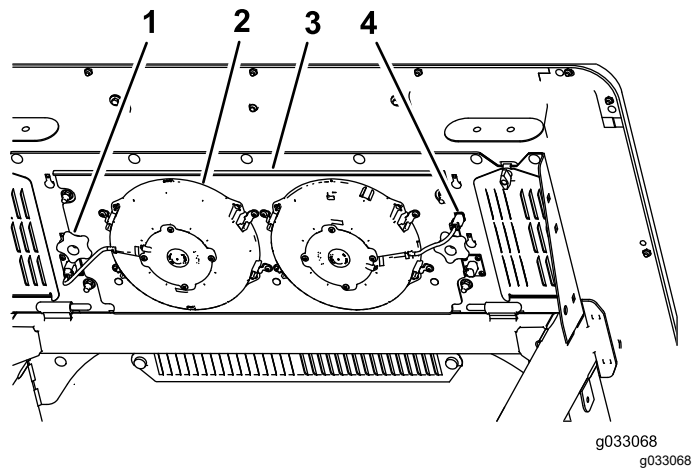

Figure 94

- | | |
|-------------|----------------------|
| 1. Knob (2) | 3. Fan panel |
| 2. Fan (2) | 4. Plug and cord (2) |

2. Clean the filters by blowing clean, oil-free, compressed air through them.

4. Remove the 2 knobs that secure the fan-panel assembly and fans to the underside of the cab top (Figure 94) and remove the assembly.
5. Clean the screen, air-conditioning duct, fans, and fan panel using low-pressure air no greater than 276 kPa (40 psi).

Important: Do not use water to clean the condenser because moisture on the components attracts dirt and dust, which make the components more difficult to clean.

6. Install the fan-panel assembly and fans to the underside of the cab top with the 2 knobs that you loosened and removed in step 4.
7. Connect the cord for the fans that you disconnected in step 3 into the outlet.
8. Install the air-conditioning screen in the opening in the top of the cab and secure it by closing the 4 tabs on the screen.

Cleaning

Cleaning the Cab

Important: Use care around the cab seals and lights (Figure 95). If you are using a pressure washer, keep the washer wand at least 0.6 m (2 ft) away from the machine. Do not use the pressure washer directly on the cab seals and lights or under the rear overhang.

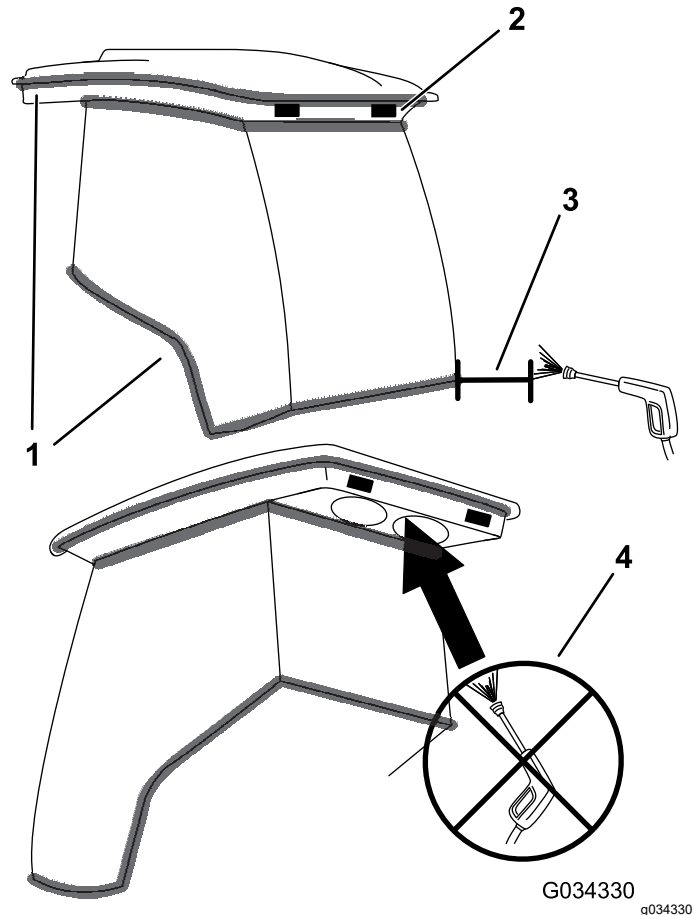

Figure 95

- | | |
|----------|--|
| 1. Seal | 3. Keep wand 0.6 m (2 ft) away. |
| 2. Light | 4. Do not pressure-wash under the rear overhang. |

Waste Disposal

Engine oil, batteries, hydraulic fluid, and engine coolant are pollutants. Dispose of these according to your state and local regulations.

Storage

Storage Safety

- Shut off the engine, remove the key, and wait for all movement to stop before you leave the operator's position. Allow the machine to cool before adjusting, servicing, cleaning, or storing it.
- Do not store the machine or fuel container where there is an open flame, spark, or pilot light, such as on a water heater or other appliance.

Preparing the Machine

1. Thoroughly clean the machine, the deck, and the engine, paying special attention to the following areas:
 - Radiator and radiator screen
 - Counterbalance springs
 - PTO-shaft assembly
 - All grease fittings and pivot points
 - Inside of the control box (Remove the control panel for access.)
 - Beneath the seat plate and the top of the transmission
2. Check and adjust the tire pressure; refer to [Checking the Tire Pressure \(page 58\)](#).
3. Check all fasteners for looseness and tighten them as necessary.
4. Grease or oil all grease fittings, pivot points, and transmission bypass-valve pins. Wipe off any excess lubricant.
5. Lightly sand and use touch-up paint on painted areas that are scratched, chipped, or rusted. Repair any dents in the metal body.
6. Service the battery and cables as follows:
 - A. Remove the battery terminals from the battery posts.
 - B. Clean the battery, terminals, and posts with a wire brush and baking-soda solution.
 - C. Coat the cable terminals and battery posts with Grafo 112X skin-over grease (Toro Part No. 505-47) or petroleum jelly to prevent corrosion.
 - D. Slowly charge the battery for 24 hours every 60 days to prevent lead sulfation of the battery.

2. Change the engine oil and filter; refer to [Changing the Engine Oil and Filter \(page 53\)](#).
3. Fill the engine with the designated quantity of engine oil; refer to [Checking the Engine-Oil Level \(page 53\)](#).
4. Start the engine and run it at idle speed for 2 minutes.
5. Drain the fuel from the fuel tank, fuel lines, pump, filter, and separator. Flush the fuel tank with clean diesel fuel and connect all fuel lines.
6. Thoroughly clean and service the air-cleaner assembly.
7. Seal the air-cleaner inlet and the exhaust outlet with weatherproof masking tape.
8. Check the oil-filler cap and fuel-tank cap to ensure that they are securely in place.

Preparing the Engine

1. Drain the engine oil from the oil pan and install the drain plug.

Notes:

EEA/UK Privacy Notice

Toro's Use of Your Personal Information

The Toro Company ("Toro") respects your privacy. When you purchase our products, we may collect certain personal information about you, either directly from you or through your local Toro company or dealer. Toro uses this information to fulfil contractual obligations - such as to register your warranty, process your warranty claim or to contact you in the event of a product recall - and for legitimate business purposes - such as to gauge customer satisfaction, improve our products or provide you with product information which may be of interest. Toro may share your information with our subsidiaries, affiliates, dealers or other business partners in connection these activities. We may also disclose personal information when required by law or in connection with the sale, purchase or merger of a business. We will never sell your personal information to any other company for marketing purposes.

Retention of your Personal Information

Toro will keep your personal information as long as it is relevant for the above purposes and in accordance with legal requirements. For more information about applicable retention periods please contact legal@toro.com.

Toro's Commitment to Security

Your personal information may be processed in the US or another country which may have less strict data protection laws than your country of residence. Whenever we transfer your information outside of your country of residence, we will take legally required steps to ensure that appropriate safeguards are in place to protect your information and to make sure it is treated securely.

Access and Correction

You may have the right to correct or review your personal data, or object to or restrict the processing of your data. To do so, please contact us by email at legal@toro.com. If you have concerns about the way in which Toro has handled your information, we encourage you to raise this directly with us. Please note that European residents have the right to complain to your Data Protection Authority.

California Proposition 65 Warning Information

What is this warning?

You may see a product for sale that has a warning label like the following:



WARNING: Cancer and Reproductive Harm—www.p65Warnings.ca.gov.

What is Prop 65?

Prop 65 applies to any company operating in California, selling products in California, or manufacturing products that may be sold in or brought into California. It mandates that the Governor of California maintain and publish a list of chemicals known to cause cancer, birth defects, and/or other reproductive harm. The list, which is updated annually, includes hundreds of chemicals found in many everyday items. The purpose of Prop 65 is to inform the public about exposure to these chemicals.

Prop 65 does not ban the sale of products containing these chemicals but instead requires warnings on any product, product packaging, or literature with the product. Moreover, a Prop 65 warning does not mean that a product is in violation of any product safety standards or requirements. In fact, the California government has clarified that a Prop 65 warning "is not the same as a regulatory decision that a product is 'safe' or 'unsafe.'" Many of these chemicals have been used in everyday products for years without documented harm. For more information, go to <https://oag.ca.gov/prop65/faqs-view-all>.

A Prop 65 warning means that a company has either (1) evaluated the exposure and has concluded that it exceeds the "no significant risk level"; or (2) has chosen to provide a warning based on its understanding about the presence of a listed chemical without attempting to evaluate the exposure.

Does this law apply everywhere?

Prop 65 warnings are required under California law only. These warnings are seen throughout California in a wide range of settings, including but not limited to restaurants, grocery stores, hotels, schools, and hospitals, and on a wide variety of products. Additionally, some online and mail order retailers provide Prop 65 warnings on their websites or in catalogs.

How do the California warnings compare to federal limits?

Prop 65 standards are often more stringent than federal and international standards. There are various substances that require a Prop 65 warning at levels that are far lower than federal action limits. For example, the Prop 65 standard for warnings for lead is 0.5 µg/day, which is well below the federal and international standards.

Why don't all similar products carry the warning?

- Products sold in California require Prop 65 labelling while similar products sold elsewhere do not.
- A company involved in a Prop 65 lawsuit reaching a settlement may be required to use Prop 65 warnings for its products, but other companies making similar products may have no such requirement.
- The enforcement of Prop 65 is inconsistent.
- Companies may elect not to provide warnings because they conclude that they are not required to do so under Prop 65; a lack of warnings for a product does not mean that the product is free of listed chemicals at similar levels.

Why does Toro include this warning?

Toro has chosen to provide consumers with as much information as possible so that they can make informed decisions about the products they buy and use. Toro provides warnings in certain cases based on its knowledge of the presence of one or more listed chemicals without evaluating the level of exposure, as not all the listed chemicals provide exposure limit requirements. While the exposure from Toro products may be negligible or well within the "no significant risk" range, out of an abundance of caution, Toro has elected to provide the Prop 65 warnings. Moreover, if Toro does not provide these warnings, it could be sued by the State of California or by private parties seeking to enforce Prop 65 and subject to substantial penalties.



The Toro Warranty

Two-Year or 1,500 Hours Limited Warranty

Conditions and Products Covered

The Toro Company warrants your Toro Commercial product ("Product") to be free from defects in materials or workmanship for 2 years or 1,500 operational hours*, whichever occurs first. This warranty is applicable to all products with the exception of Aerators (refer to separate warranty statements for these products). Where a warrantable condition exists, we will repair the Product at no cost to you including diagnostics, labor, parts, and transportation. This warranty begins on the date the Product is delivered to the original retail purchaser.

* Product equipped with an hour meter.

Instructions for Obtaining Warranty Service

You are responsible for notifying the Commercial Products Distributor or Authorized Commercial Products Dealer from whom you purchased the Product as soon as you believe a warrantable condition exists. If you need help locating a Commercial Products Distributor or Authorized Dealer, or if you have questions regarding your warranty rights or responsibilities, you may contact us at:

Toro Commercial Products Service Department
8111 Lyndale Avenue South
Bloomington, MN 55420-1196

952-888-8801 or 800-952-2740
E-mail: commercial.warranty@toro.com

Owner Responsibilities

As the product owner, you are responsible for required maintenance and adjustments stated in your *Operator's Manual*. Repairs for product issues caused by failure to perform required maintenance and adjustments are not covered under this warranty.

Items and Conditions Not Covered

Not all product failures or malfunctions that occur during the warranty period are defects in materials or workmanship. This warranty does not cover the following:

- Product failures which result from the use of non-Toro replacement parts, or from installation and use of add-on, or modified non-Toro branded accessories and products.
- Product failures which result from failure to perform recommended maintenance and/or adjustments.
- Product failures which result from operating the Product in an abusive, negligent, or reckless manner.
- Parts consumed through use that are not defective. Examples of parts which are consumed, or used up, during normal Product operation include, but are not limited to, brake pads and linings, clutch linings, blades, reels, rollers and bearings (sealed or greasable), bed knives, spark plugs, castor wheels and bearings, tires, filters, belts, and certain sprayer components such as diaphragms, nozzles, flow meters, and check valves.
- Failures caused by outside influence, including, but not limited to, weather, storage practices, contamination, use of unapproved fuels, coolants, lubricants, additives, fertilizers, water, or chemicals.
- Failure or performance issues due to the use of fuels (e.g. gasoline, diesel, or biodiesel) that do not conform to their respective industry standards.
- Normal noise, vibration, wear and tear, and deterioration. Normal "wear and tear" includes, but is not limited to, damage to seats due to wear or abrasion, worn painted surfaces, scratched decals or windows.

Countries Other than the United States or Canada

Customers who have purchased Toro products exported from the United States or Canada should contact their Toro Distributor (Dealer) to obtain guarantee policies for your country, province, or state. If for any reason you are dissatisfied with your Distributor's service or have difficulty obtaining guarantee information, contact your Authorized Toro Service Center.

Parts

Parts scheduled for replacement as required maintenance are warranted for the period of time up to the scheduled replacement time for that part. Parts replaced under this warranty are covered for the duration of the original product warranty and become the property of Toro. Toro will make the final decision whether to repair any existing part or assembly or replace it. Toro may use remanufactured parts for warranty repairs.

Deep Cycle and Lithium-Ion Battery Warranty

Deep cycle and Lithium-Ion batteries have a specified total number of kilowatt-hours they can deliver during their lifetime. Operating, recharging, and maintenance techniques can extend or reduce total battery life. As the batteries in this product are consumed, the amount of useful work between charging intervals will slowly decrease until the battery is completely worn out. Replacement of worn out batteries, due to normal consumption, is the responsibility of the product owner. Note: (Lithium-Ion battery only): Refer to the battery warranty for additional information.

Lifetime Crankshaft Warranty (ProStripe 02657 Model Only)

The ProStripe which is fitted with a genuine Toro Friction Disc and Crank-Safe Blade Brake Clutch (integrated Blade Brake Clutch (BBC) + Friction Disc assembly) as original equipment and used by the original purchaser in accordance with recommended operating and maintenance procedures, are covered by a Lifetime Warranty against engine crankshaft bending. Machines fitted with friction washers, Blade Brake Clutch (BBC) units and other such devices are not covered by the Lifetime Crankshaft Warranty.

Maintenance is at Owner's Expense

Engine tune-up, lubrication, cleaning and polishing, replacement of filters, coolant, and completing recommended maintenance are some of the normal services Toro products require that are at the owner's expense.

General Conditions

Repair by an Authorized Toro Distributor or Dealer is your sole remedy under this warranty.

The Toro Company is not liable for indirect, incidental or consequential damages in connection with the use of the Toro Products covered by this warranty, including any cost or expense of providing substitute equipment or service during reasonable periods of malfunction or non-use pending completion of repairs under this warranty. Except for the Emissions warranty referenced below, if applicable, there is no other express warranty. All implied warranties of merchantability and fitness for use are limited to the duration of this express warranty.

Some states do not allow exclusions of incidental or consequential damages, or limitations on how long an implied warranty lasts, so the above exclusions and limitations may not apply to you. This warranty gives you specific legal rights, and you may also have other rights which vary from state to state.

Note Regarding Emissions Warranty

The Emissions Control System on your Product may be covered by a separate warranty meeting requirements established by the U.S. Environmental Protection Agency (EPA) and/or the California Air Resources Board (CARB). The hour limitations set forth above do not apply to the Emissions Control System Warranty. Refer to the Engine Emission Control Warranty Statement supplied with your product or contained in the engine manufacturer's documentation.