

User Manual and Parts  
Book of the

## Verti-Comb

Serial number:

Translation of the original operating  
instructions

**REDEXIM**

Kwekerijweg 8  
3709 JA Zeist  
the Netherlands  
T: (31)30 6933227  
F: (31)30 6933228  
E: [verti-drain@redexim.com](mailto:verti-drain@redexim.com)  
[www.redexim.com](http://www.redexim.com)

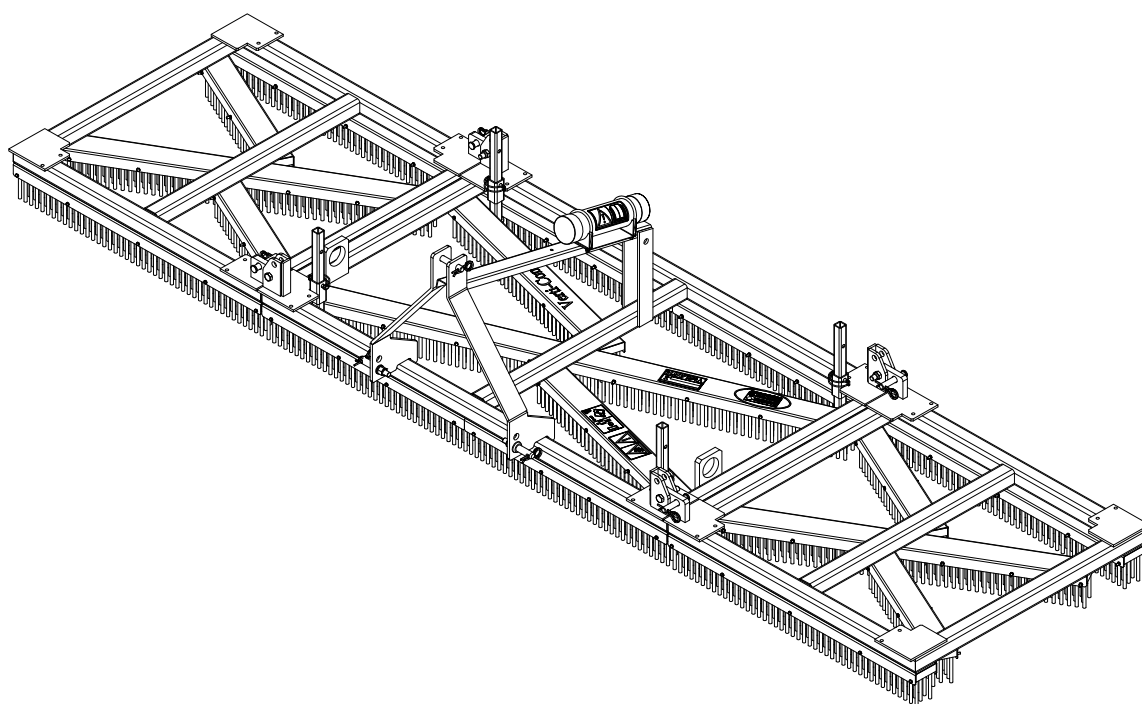
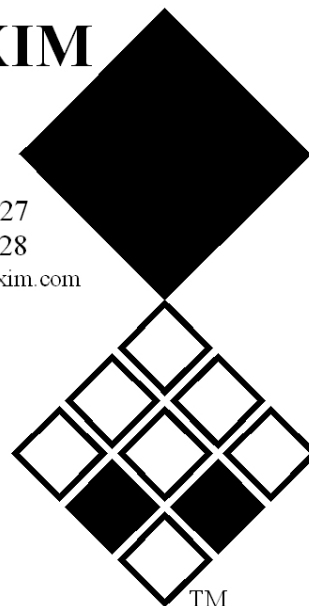

**ATTENTION:**



**IT IS OF THE UTMOST IMPORTANCE TO READ THIS USER MANUAL CAREFULLY PRIOR TO USING THE VERTI-COMB IN ORDER TO USE THE MACHINE SAFELY AND TO OBTAIN THE BEST RESULTS.**

## FOREWORD

Congratulations on your Verti-Comb purchase! For safe and long-lasting operation of this Verti-Comb, it is necessary to read and to understand this user manual. It is impossible to work safely with this machine *without* complete knowledge of its content.

The Verti-Comb is not a machine that works independently. It is the user's responsibility to use the correct tractor. The user must also check the tractor/Verti-Comb combination on safety aspects such as noise level, user instructions and risk analysis.

The following pages deal initially with the general safety instructions. Every user should know these safety instructions and apply them. At the end of this page, a registration card is inserted. This registration card should be returned to enable us to deal with potential future claims.

This user manual lists many instructions that are numbered in sequence. You should follow this sequence. A  is an indication of a safety instruction. A  means a tip and/or note.

All information and technical specifications provided at the moment that this document is published are the most recent ones. Design specifications may be changed without prior notice.

This document is a translation of the original operating instructions.  
Upon request, the original operating instructions are available in Dutch.

## WARRANTY CONDITIONS

WITH DELIVERY THIS VERTI-COMB IS GUARANTEED AGAINST MATERIAL DEFECTS. THIS WARRANTY IS VALID FOR A PERIOD OF 12 MONTHS FROM THE PURCHASE DATE. VERTI-COMB WARRANTIES ARE SUBJECT TO THE 'GENERAL CONDITIONS FOR SUPPLY OF PLANT AND MACHINERY FOR EXPORT, NUMBER 188' THAT ARE PUBLISHED UNDER THE AUSPICES OF THE UNITED NATIONS ECONOMIC COMMISSION FOR EUROPE.

## REGISTRATION CARD

For your own information, fill in the table below:

Serial number of the machine	
Dealer name	
Date of purchase	
Remarks	

## ! SAFETY INSTRUCTIONS !

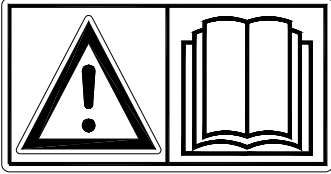
 <p>Figure 1</p>	<p>The Verti-Comb is designed for safe use. This can only be achieved if you completely follow the safety instructions described in this manual.</p> <p><b>Read and understand</b> (Figure 1) the manual <i>before</i> you start using the Verti-Comb.</p> <p>If the machine is not used as described in this manual, this can result in injuries and/or damage to the Verti-Comb.</p>
---	--

1. The user must be an expert in using the machine. The machine should be professionally adjusted for cultivating the subsoil.

The manufacturer will not accept any liability for unprofessional use and its resulting damage. All risks occurring with this are entirely at the expense of the user. Not following the use, maintenance and repair instructions prescribed by the manufacturer is also considered unprofessional use of this machine.

Inspect the area to be treated *before* using the Verti-Comb.  
Remove loose obstacles and avoid irregularities.

2. The Verti-Comb is manufactured according to the latest technical understanding and is safe to use.

When unskilled people use, maintain or repair the machine, this could result in injuries to the user *and* to third parties. **This must be avoided!**

Always use the Verti-Comb in combination with the correct tractor as described in the technical data.

3. All persons assigned to operate, maintain and repair the Verti-Comb by the owner must read and completely understand the operation manual and in particular the chapter of **Safety Instructions**.

The user is responsible for a **safe Tractor/Verti-Comb combination**. **This entire combination must be tested** for noise, safety, risk and user friendliness. User instructions should also be drafted.

4. The user is **obliged to check** the Verti-Comb for **visible damage and defects** before using the Verti-Comb.

Modifications to the Verti-Comb (including its operations) that have a negative impact on safety must be rectified immediately.

For safety reasons it is in principle not permitted to make changes or adjustments to the Verti-Comb (except those approved by the manufacturer).

If **modifications** to the Verti-Comb have been made, then the current CE marking is cancelled. The person that has made these modifications has to apply for a new **CE marking himself**.

Check the Verti-Comb for loose bolts, nuts and components *before* every operation.

If present, check the hydraulic pipelines regularly and replace these when the hydraulic pipelines are damaged or appear old. The pipelines that are replaced should comply with the technical requirements of the manufacturer.

If a hydraulic installation is present, you should **always** make it pressure-free *before* working on this installation.

**NEVER** use the Verti-Comb in the absence of the safety stickers.

**NEVER** crawl under the Verti-Comb.  
If necessary, tilt the Verti-Comb.

**NEVER** step off the tractor while the motor is running.

In case of maintenance, adjusting and repairs, it is necessary to block the Verti-Comb in order to prevent sinking away, driving off and/or sliding off.

**Always switch off the tractor motor and take the tractor's key out of the ignition** in carrying out maintenance, adjustments and repairs (Figure 2).

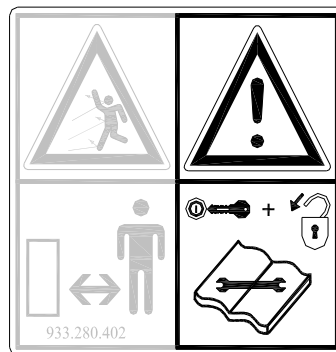

Figure 2

With regards to the safety of the machine and the user, use only original Verti-Comb parts for maintenance and repairs.

Only authorised technical personnel may carry out repairs to the Verti-Comb.

**Keep a record of the repair activities.**

5. The general applicable health & safety (Dutch: ARBO) regulations must also be followed in addition to the instructions in this user manual.

Relevant traffic regulations also apply in case of using public roads.

**Transporting persons is not permitted!**

Do not use the Verti-Comb in the dark, in heavy rain/storm or on slopes with an angle larger than 20 degrees.

6. All persons that are going to operate the Verti-Comb must be familiar with all the functions and control elements of the Verti-Comb *before* starting any work activities.

Attach the Verti-Comb to the towing vehicle according to the regulations.

**(Danger of injuries!)**

Check whether you have a clear field of vision – both close by and far away – *before* you depart.

Safety stickers (Figure 2, 3 and 4) with an identical meaning are attached to both sides (Figure 5) of the Verti-Comb. These safety stickers must always be clearly visible and legible and must be replaced if they have become damaged.

During operation, **NO persons are allowed within the danger zone** of the Verti-Comb, because there is danger of physical injuries caused by flying material (Figure 3).



Figure 3



Figure 4

**Keep a distance of minimum 4 metres!** (Figure 4)

Pay attention to the permitted lifting capacity of the towing vehicle.

Dress appropriately. Wear sturdy shoes with steel toecaps, long trousers and tie up long hair. Do not wear loose clothing.

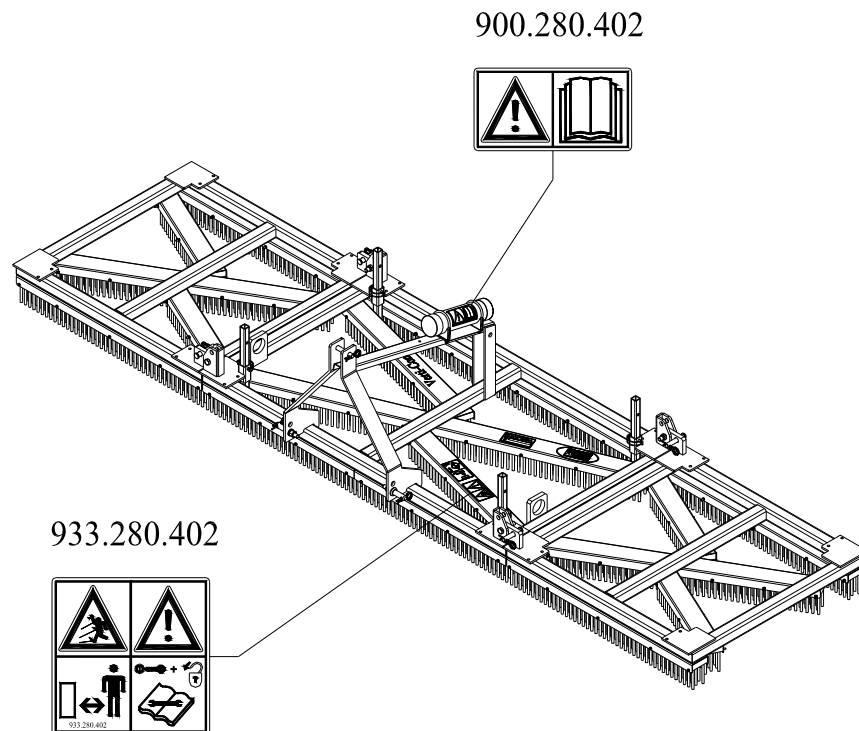

Figure 5

7. Location of the safety stickers (Figure 5).

## TABLE OF CONTENTS

WARRANTY CONDITIONS .....	2
REGISTRATION CARD .....	2
SAFETY INSTRUCTIONS .....	3
1.0 TECHNICAL DATA .....	8
2.0 FIRST INSTALLATION – TAKING THE MACHINE OFF THE PALLET ..	9
3.0 ATTACHING IT TO THE TRACTOR.....	10
4.0 TRANSPORTING THE VERTI-COMB .....	11
5.0 DRIVING SPEED.....	11
6.0 OPERATING THE VERTI-COMB.....	12
7.0 START/STOP PROCEDURE .....	12
8.0 DISCONNECTING THE VERTI-COMB.....	13
9.0 TROUBLE SHOOTING (PROBLEM ANALYSIS).....	13
10.0 EU DECLARATION.....	14
11.0 MAINTENANCE .....	14
12.0 OPTIONAL: SET OF WHEELS WITH TOWING HOOK .....	15
13.0 OPTIONAL: RAKE SECTION .....	16
14.0 OPTIONAL: MAGNET SECTION.....	17
15.0 OPTIONAL: HYDRAULIC KIT .....	18

## 1.0 TECHNICAL DATA

<u>Model</u>	<u>Verti-Comb 1800</u>	<u>Verti-Comb 400</u>
Working width	1.8 m (70.9") only the middle section	4.0 m (157.5")
Working depth	Surface treatment	Surface treatment
Speed	Maximum 12 km/h (7.5 mph)	Maximum 12 km/h (7.5 mph)
Weight of basic machine Weight of basic machine including options	150 kg (331 lbs) -	250 kg (551 lbs) 545 kg (1202 lbs)
Recommended tractor	30 HP with minimum lifting capacity of 500 kg (1102,3 lbs)  In case of the hydraulic version, 1 double-functioning hydraulic connection	30 HP with minimum lifting capacity of 700 kg (1543.2 lbs)  In case of the hydraulic version, 1 double-functioning hydraulic connection
Maximum capacity (Theoretical at maximum speed of 12 km/h [7.5mph])	21600 m <sup>2</sup> /h (232500,5 ft <sup>2</sup> /h)	48000 m <sup>2</sup> /h (516667.7 ft <sup>2</sup> /h)
Transport dimensions	L x W x H 775 x 1800x 1500 mm 30.5" x 70.9" x 59"	L x W x H 1175 x 2220 x 1610 mm 46.3" x 87.4" x 63.4"
Three-point connection	Cat. 1-2	Cat. 1-2
Standard components	- Integrated adjustable legs	- Integrated adjustable legs
Optional	- Set of wheels - Towing hook - Rake section - Magnet section - Hydraulic kit	- Set of wheels - Towing hook - Rake section - Magnet section - Hydraulic kit



## 2.0 FIRST INSTALLATION – TAKING THE MACHINE OFF THE PALLET

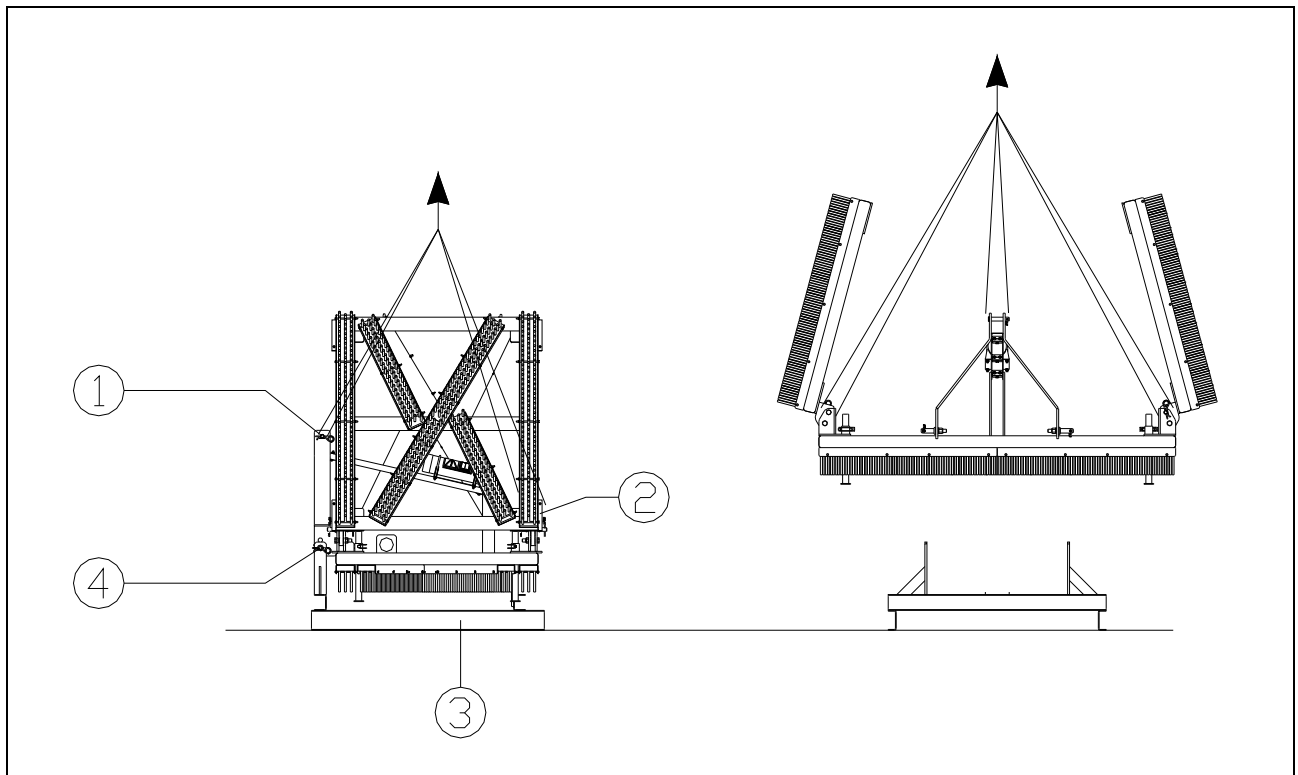

Figure 6

To remove the pallet and to place the machine horizontally on the ground, you take the following steps (see Figure 6):

**⚠ !! NEVER CRAWL UNDER THE MACHINE !!**

1. Attach a cable to lifting point (1) and to the frame of the machine (2).

**⚠ Make sure that the cable/crane/lift can hoist minimum 1,000 kg (2205 lbs).**

**⚠ Careful: Keep your distance; the machine can slide!**

2. Remove the bottom 3-points pins (4).

3. Lift the machine carefully a little bit off the pallet.

4. Remove the pallet and lower the machine calmly until it stands completely on the ground.

5. Connect the machine to the tractor (please refer to Chapter 3.0).

**⚠ Use the proper tractor (please refer to the specifications).**

**⚠ Turn off the tractor and secure the tractor/Verti-Comb combination against driving off and/or sliding off.**

### 3.0 ATTACHING IT TO THE TRACTOR

Checking procedure before starting to attach the Verti-Comb:

- Check the Verti-Comb for visually discernable damage and repair this if safe operation of the machine is no longer guaranteed.
- Check whether all the nuts and bolts are tight.
- Check whether all safety stickers are present on the machine and are not damaged.

**NEVER** use the machine without these items.

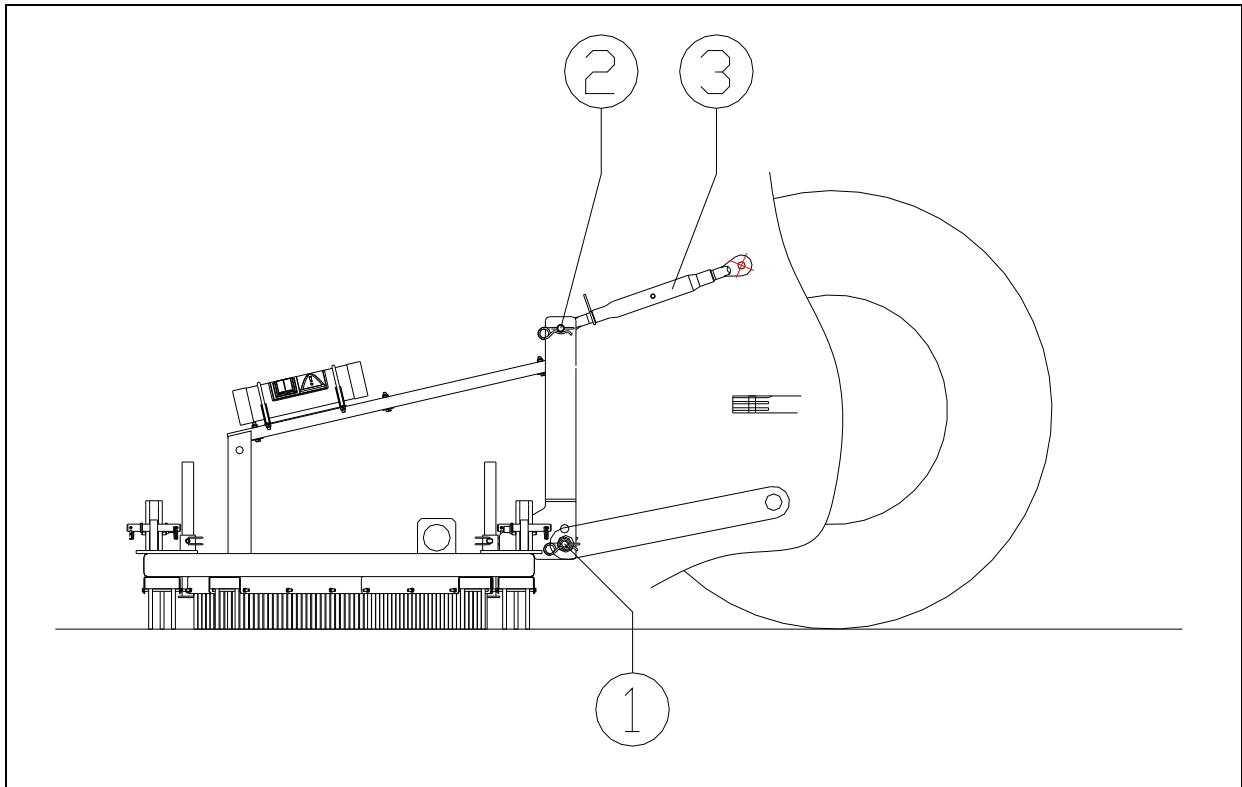

Figure 7

The Verti-Comb can be attached to the tractor by means of the 3-point attachment.

The procedure is as follows (see Figure 7):

1. Remove the 3-point pin (2).
2. Drive the tractor carefully backwards so that the lower connecting arms can be attached to the frame.

**⚠ !! Make sure that the pulling vehicle is blocked well and cannot move on its own accord !!**

**⚠ !! Switch off the pulling vehicle before descending !!**

3. Connect the lower connecting arms to the 3-point pins (1) and secure these with the supplied locking pins.
4. Set the stabilizer of the tractor to 100 mm lateral stroke.
5. Mount the top rod of your tractor and turn it outward until it reaches the same height as the 3-point stop connection of the Verti-Comb.

Connect the top rod (3) to the frame with the pin (2); secure the pin (2) with the supplied securing pin.  
Turn the top rod inwards so that it becomes pressurized.

**⚠ !! Make sure that all the securing pins are locked !!**

Start the tractor and lift the Verti-Comb off the ground.

Detaching is done in reverse order.

#### 4.0 TRANSPORTING THE VERTI-COMB

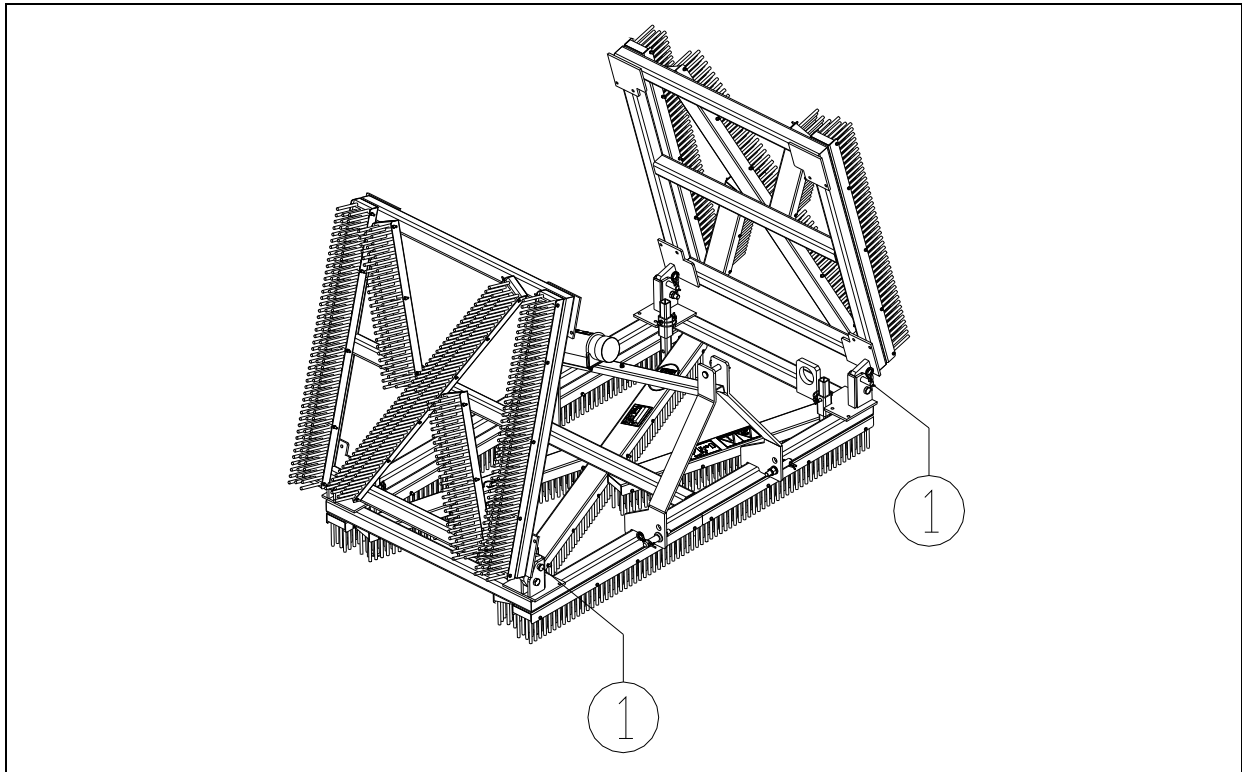

Figure 8

The user is responsible for transporting the Verti-Comb in back of the tractor on public roads. Verify the national legislation regarding the regulations.

On open fields while the machine is raised, the maximum permitted speed is 12 km/h (7.5 mph) due to the weight of the Verti-Comb.

A higher speed can be dangerous for the driver and/or the public and can even damage the machine.

**⚠ When the machine is raised off the ground, the front axle of the tractor has to support minimum 20% of its weight.**

**⚠ Always transport the Verti-Comb with the side-panels folded! Secure the locking mechanism (1) with the locking pin (see Figure 8).**

#### 5.0 DRIVING SPEED

The driving speed is limited to 12 km/h (7.5mph).

It is NOT recommended to drive faster due to the fact that excessive wear & tear and damage can occur to the machine and to the subsoil.

## 6.0 OPERATING THE VERTI-COMB

Before using the Verti-Comb in a location, you should check the following items:

1. Are there loose objects in the field? First remove these objects.
2. Are there slopes? The maximum slope is 20 degrees for this machine.
3. Is there danger of flying objects (e.g., balls) that distract the attention of the driver? If so, the Verti-Comb **CANNOT** be used.
4. Is there danger of sinking/sliding away? If so, postpone the processing until conditions improve.
5. A field can be worked several times in the same or different directions in order to obtain better processing.
6. Do not make sharp bends and preferably, drive in straight lines; otherwise you might damage the machine and the ground.

## 7.0 START/STOP PROCEDURE

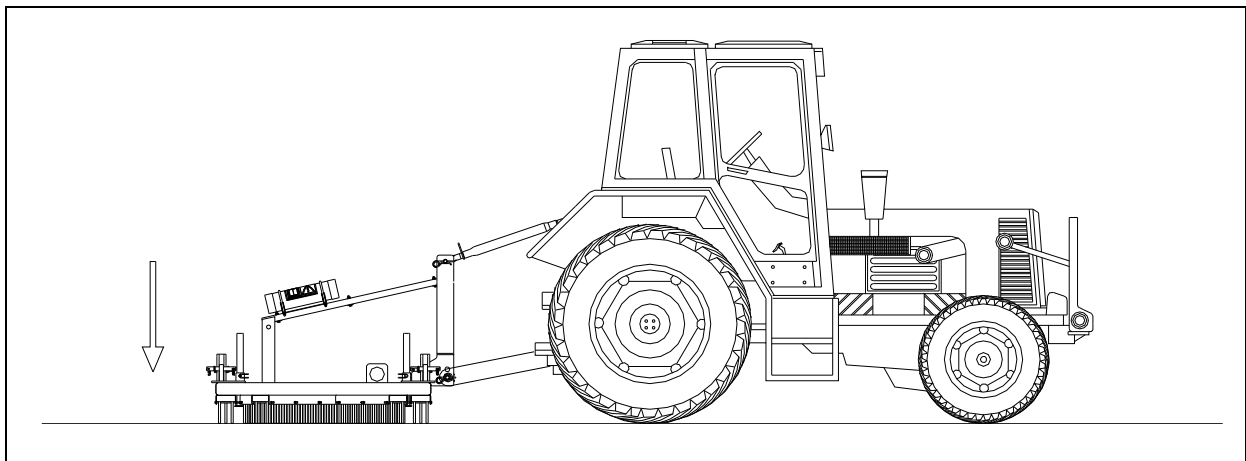

Figure 9

The start procedure is **VERY** important. If this procedure is not executed as described below, it might result in serious damage to the subsoil.

The start procedure is as follows: (see Figure 9)

1. Check the Verti-Comb for loose components and look whether all components function properly.

**⚠ !! If loose components are observed or components do not function properly, the problems must be solved *before* using the Verti-Comb !!**

2. Drive to the location that needs to be treated and lower the machine until it is completely on the ground.

**⚠ !! Make sure that the tractor is blocked well and cannot move on its own accord !!**

**⚠ !! Switch off the tractor before descending !!**

3. Remove the locking pins and unfold the side-panels.
4. Turn the top rod tight until the machine stands completely flat on the ground.
5. Move the tractor forwards.
6. Increase the driving speed to maximum 12 km/h (7.5 mph).

Stopping occurs as follows:

1. Lower the speed and lift the machine from the ground.
2. Lift the machine completely and drive to the next location.

## 8.0 DISCONNECTING THE VERTI-COMB

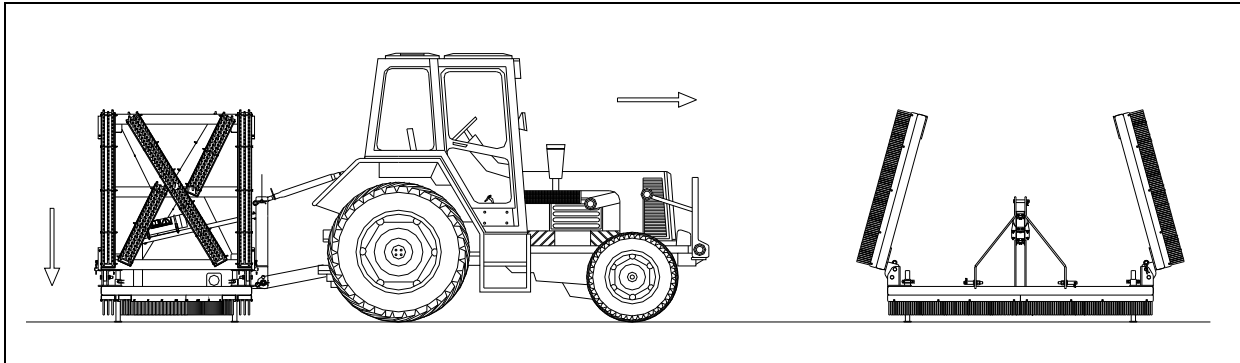

Figure 10

The machine can be disconnected in the following manner: (see Figure 10)

- ⚠ **!! Make sure that the tractor is blocked well and cannot move on its own accord !!**
  - ⚠ **!! Switch off the tractor before descending !!**
1. Fold the side-panels up and mount the locking pins in the securing pins.
  2. Drive the Verti-Comb to a parking area with a firm/flat surface.
  3. Lower the adjustable legs and secure these with the locking pins.
  4. Carefully lower the Verti-Comb to the ground.
  5. Release the top rod.
  6. Take the securing pin out of the top rod pin and pull the pin out of the top rod connection.
  7. Take the securing pins out of the bottom 3-point pins and disconnect the lower lifting arms from the tractor.
- ⚠ **!! Make sure that the Verti-Comb stands stable and cannot roll away and/or slide off !!**
8. Start the tractor and drive off.

## 9.0 TROUBLE SHOOTING (PROBLEM ANALYSIS)

Problem	Possible cause	Solution
Levelled too little material.	- Ground is too hard	- Drive another few passes. - Use rakes.
Sloppy image of the field after processing	- Ground is too wet - You have driven too slowly.	- Wait for better conditions - Increase the driving speed
Optional: Rakes go too deep.	- Wrongly adjusted	- Swivel the top rod out. - Adjust the working depth.

## 10.0 EU DECLARATION

We – Redexim BV, Utrechtseweg 127, 3702 AC Zeist, Holland – declare entirely under our own responsibility that the product

**VERTI-COMB WITH MACHINE NUMBER AS INDICATED ON THE MACHINE AND IN THIS MANUAL,** to which this declaration relates is according to the stipulation of the 2006/42/EC directive for machines.

Zeist, 01/10/09



**A.C. Bos**  
Manager Operations & Logistics  
Redexim Holland

## 11.0 MAINTENANCE

Time schedule	Check/Grease point	Method
Before <b><u>every</u></b> use	Check for loose bolts/nuts  If installed: Check the hydraulic system for damage.  Presence and readability of the safety stickers (Figure 5)	Tighten loose bolts/nuts with the correct torque.  Replace or repair components.  Replace these if not present or damaged.

## 12.0 OPTIONAL: SET OF WHEELS WITH TOWING HOOK

The Verti-Comb is also available including a set of wheels (optional). (Figure 11)  
This set can be mounted at the inside of the machine.  
The set of wheels is used in combination with a towing hook when another pulling vehicle is used instead of a tractor.

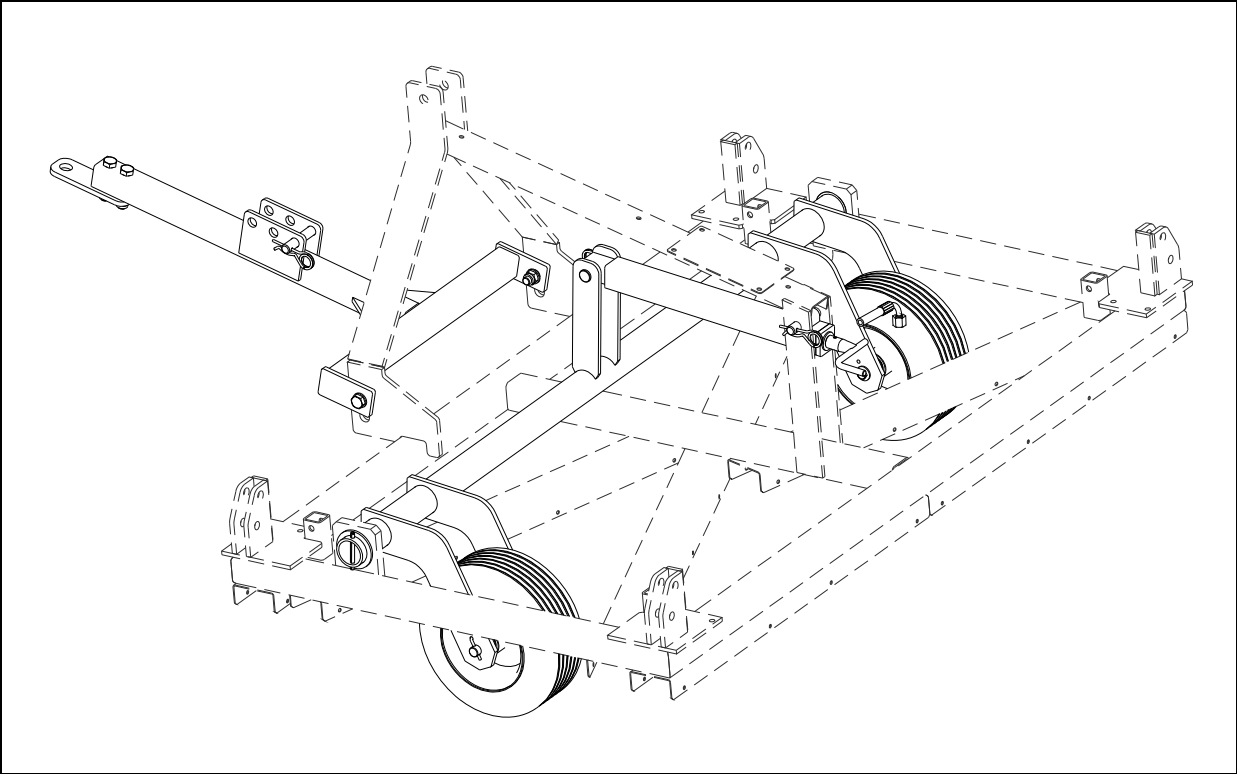

Figure 11

### 13.0 OPTIONAL: RAKE SECTION

The Verti-Comb is also available including a rake section (optional). (Figure 12)  
This section can be mounted at the front side or the backside of the machine.  
The rake section can be used to rake (loosen) any material that is stuck.

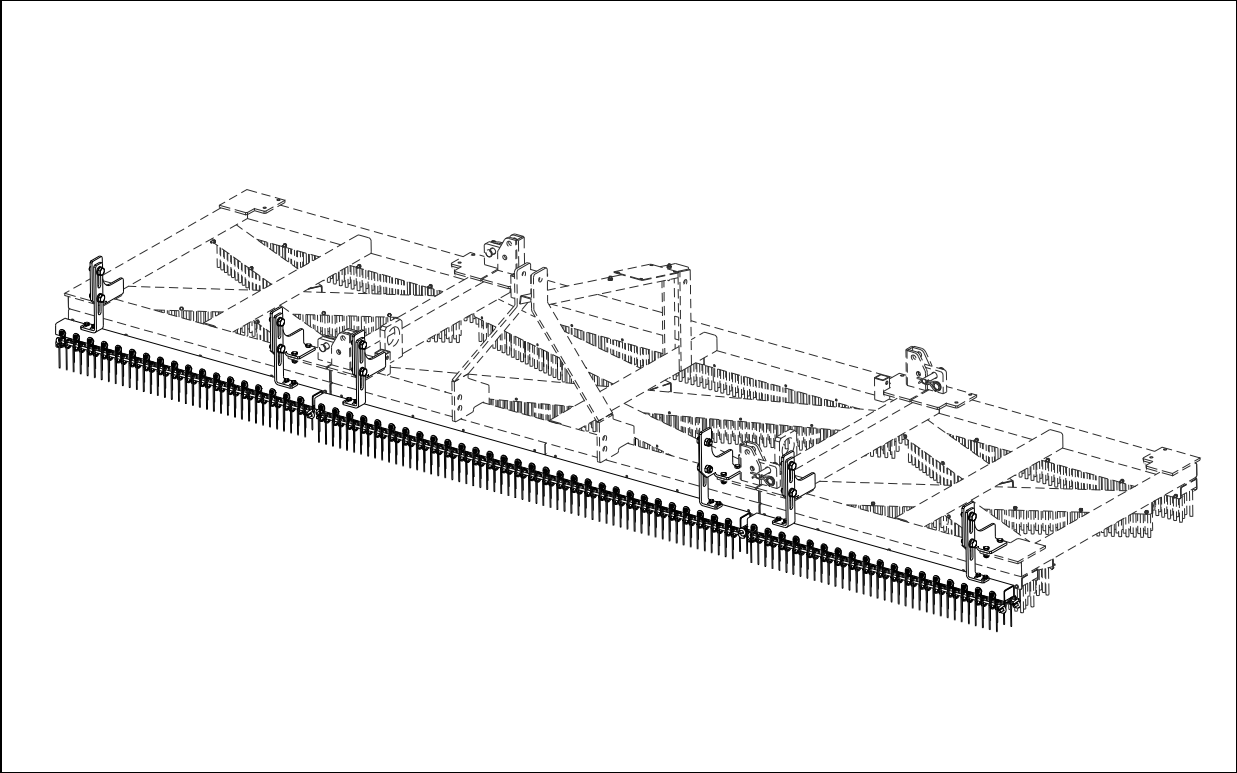

Figure 12



# 14.0 OPTIONAL: MAGNET SECTION

The Verti-Comb is also available including a magnet section (optional). (Figure 13)  
This section can be mounted at the backside of the machine.  
While treating the surface, the magnet section can be used to remove steel particles from the surface.

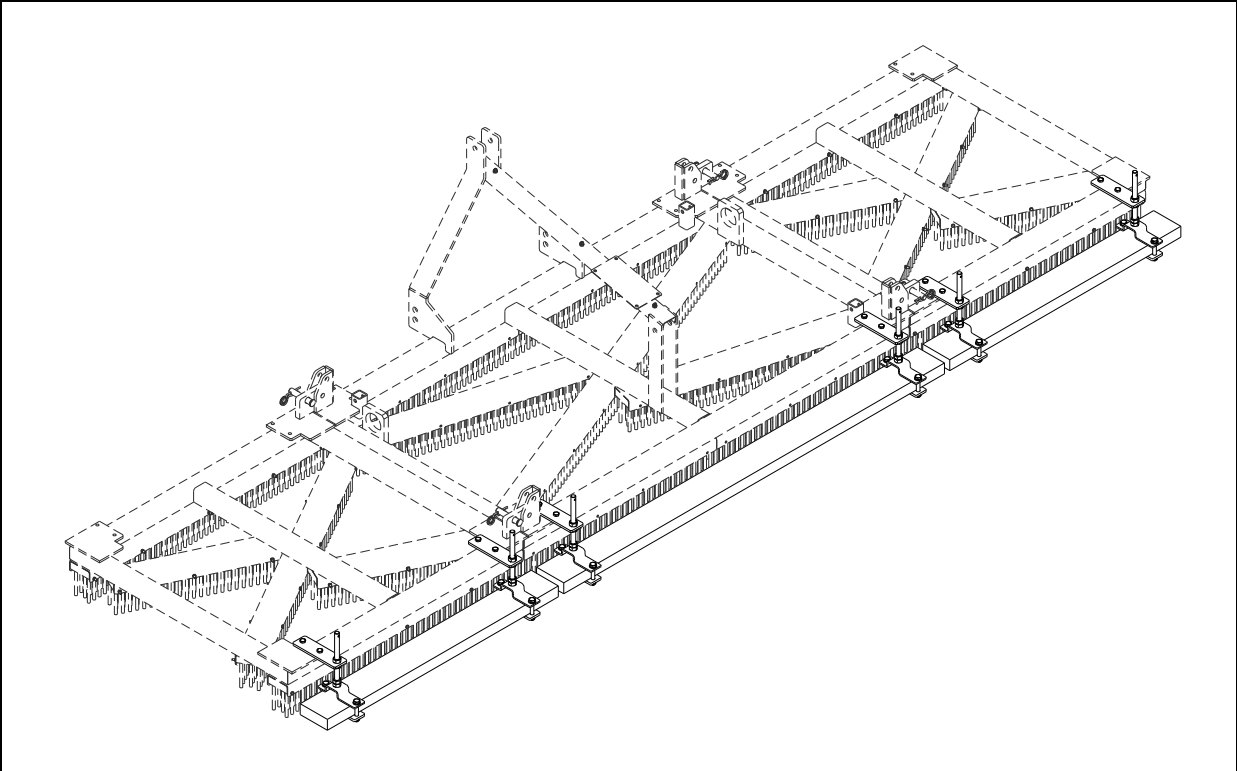

Figure 13

# 15.0 OPTIONAL: HYDRAULIC KIT

The Verti-Comb is also available including a hydraulic kit (optional). (Figure 14)  
This kit can be mounted on the backside of the machine by means of brackets.  
The hydraulic kit enables the automatic folding up or down of the side-panels and the automatic raising or lowering of the set of wheels.

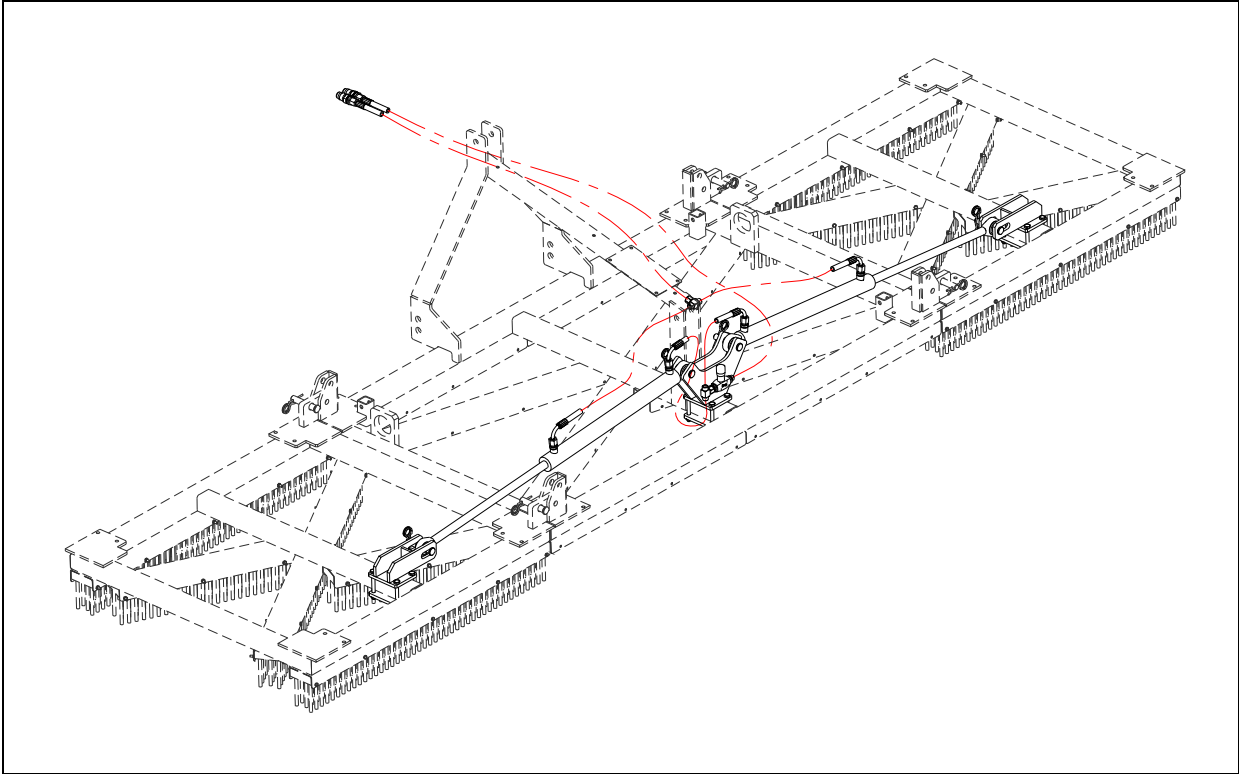

Figure 14