

TOP BRUSH 6000

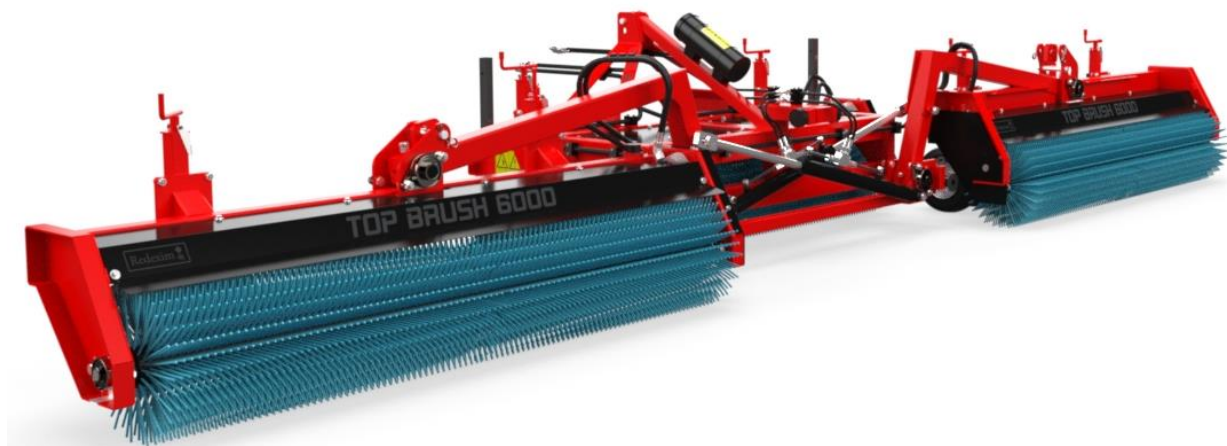

Translation of the original user manual



2206 English 942.120.004 EN



Kwekerijweg 8 | 3709JA | Zeist | The Netherlands |
T: +31 (0)306 933 227
E: redexim@redexim.com
W: www.redexim.com

EU – DECLARATION OF CONFORMITY



We,

Redexim Handel- en Exploitatie Maatschappij B.V.
Kwekerijweg 8
3709 JA Zeist, The Netherlands

declare that this “EU - DECLARATION OF CONFORMITY” is issued under our sole responsibility and belongs to the following product:

TOP BRUSH WITH MACHINE NUMBER AS INDICATED ON THE MACHINE AND IN THIS MANUAL.

to which this declaration refers, complies with stipulation of:

2006/42/EC Machinery Directive

and with the standards:

- **ISO 12100-1:2010** Safety of machinery - General principles for design - Risk assessment and risk reduction
- **ISO 13857:2019** Safety of machinery - Safety distances to prevent hazard zones being reached by upper and lower limbs
- **ISO 4254-1:2015** Agricultural machinery - Safety - Part 1: General requirements

Zeist, 03-01-2022

A handwritten signature in blue ink, appearing to be 'C.H.G. de Bree', written over a horizontal line.

C.H.G. de Bree

Redexim Handel- en Exploitatie Maatschappij B.V.

UK – DECLARATION OF CONFORMITY



We,

Redexim Handel- en Exploitatie Maatschappij B.V.
Kwekerijweg 8
3709 JA Zeist, The Netherlands

declare that this “UK - DECLARATION OF CONFORMITY” is issued under our sole responsibility and belongs to the following product:

TOP BRUSH WITH MACHINE NUMBER AS INDICATED ON THE MACHINE AND IN THIS MANUAL,

to which this declaration refers, complies with stipulation of:

S.I. 2008 No. 1597 HEALTH AND SAFETY The Supply of Machinery (Safety) Regulations 2008

and with the standards:

- **ISO 12100-1:2010** Safety of machinery - General principles for design - Risk assessment and risk reduction
- **ISO 13857:2019** Safety of machinery - Safety distances to prevent hazard zones being reached by upper and lower limbs
- **ISO 4254-1:2015** Agricultural machinery - Safety - Part 1: General requirements

Zeist, 03-01-2022

A handwritten signature in blue ink, appearing to read 'C.H.G. de Bree'.

C.H.G. de Bree

Redexim Handel- en Exploitatie Maatschappij B.V.

FOREWORD

Congratulations on your TOP BRUSH purchase. For safe and long-lasting operation of this machine, it is necessary to read and to understand this user manual. It is impossible to work safely with this machine *without* complete knowledge of the content of the user manual.

This machine does *not* operate independently! It is the user's responsibility to use the correct tractor or other towing vehicle. The user should check the combination of the towing vehicle and the machine with regard to various aspects, such as noise level and safety risks. In addition, the user should comply with the user instructions of the vehicle and spare parts that are used.

All information and technical specifications provided at the moment that this document is published are the most recent ones. Design specifications may be changed without prior notice.

You can contact your sales point or dealer if you have questions and/or if there are ambiguities in this manual or about the machine concerned.

WARRANTY CONDITIONS

AT THE TIME OF DELIVERY THIS MACHINE IS GUARANTEED AGAINST MATERIAL DEFECTS.

THIS WARRANTY IS VALID FOR A PERIOD OF 12 MONTHS FROM THE PURCHASE DATE.

REDEXIM WARRANTIES ARE SUBJECT TO THE 'GENERAL CONDITIONS FOR SUPPLY OF PLANT AND MACHINERY FOR EXPORT, NUMBER 188' THAT ARE PUBLISHED UNDER THE AUSPICES OF THE UNITED NATIONS ECONOMIC COMMISSION FOR EUROPE.

REGISTRATION CARD

For your own information, fill in the table below:

Serial number of the machine	
Dealer name	
Date of purchase	
Remarks	

TABLE OF CONTENTS

1.	SAFETY INSTRUCTIONS.....	6
1.1.	Obligations of the user.....	6
1.2.	Maintenance, repairs and adjustments.....	7
1.3.	Using the machine.....	7
2.	TECHNICAL DATA.....	8
3.	GENERAL DESCRIPTION.....	9
4.	SAFETY STICKERS.....	9
5.	FIRST INSTALLATION.....	10
6.	ATTACHING AND DETACHING THE MACHINE.....	14
6.1.	Attaching the machine.....	14
6.2.	Detaching the machine.....	15
7.	MACHINE SETTINGS.....	15
8.	TRANSPORT.....	15
9.	START/STOP PROCEDURE.....	16
9.1.	Safety.....	16
9.2.	Starting to brush.....	16
9.3.	Stop brushing.....	17
10.	MAINTENANCE.....	18
10.1.	Lubrication points.....	18
11.	TROUBLE SHOOTING (PROBLEM ANALYSIS).....	19
12.	OPTION: SECURITY CHAIN FOR TRANSPORT.....	20

1. SAFETY INSTRUCTIONS

This machine is designed for safe use. This can only be achieved if you completely follow the safety instructions described in this manual.

Read and understand the manual *before* you start using this machine.

If the machine is not used as described in this manual, this can result in injuries and/or damage to the machine.

This user manual lists instructions that are numbered in sequence. You should follow this sequence. A

 is an indication of a safety instruction. A  means a tip and/or note.

1.1. Obligations of the user

Treating fields/lawns is the only purpose of the machine. Any other use is improper. The manufacturer will not accept any liability for damage resulting from improper use. All risks occurring with this are entirely at the expense of the user.

All persons assigned to operate, maintain and repair the **machine** by the owner must completely read and understand the operation manual and in particular the chapter of **Safety Instructions**.

Modifications to the machine that have a negative impact on the safety must be rectified immediately.

The user is obliged to check the machine for visible damage and defects before using the machine.

For safety reasons it is not permitted to make changes or adjustments to the machine (except those approved by the manufacturer). If modifications to the machine have been made, then the current CE marking is cancelled. The person that has made these modifications has to apply for a new CE marking himself.

Following the use, maintenance and repair instructions prescribed by the manufacturer is also considered proper use of this machine.

The user is responsible for the safe combination of the machine and the towing vehicle, which comply with the requirements as described in the Technical Data (**see Chapter 2**). **This entire combination should be tested** for noise, safety, risk and user friendliness. User instructions should also be drafted.

Dress appropriately during work activities with the machine. Wear sturdy shoes with steel toecaps, long trousers and tie up long hair. Do not wear loose clothing.

The general applicable health & safety (Dutch: ARBO) regulations must also be followed in addition to the instructions in this user manual.

Relevant traffic regulations also apply in case of using public roads.

1.2. Maintenance, repairs and adjustments

Keep a record of the repair activities.

When unskilled people use, maintain or repair the machine, this could result in injuries to the user *and* to third parties. **This should be avoided!**

Use only original **Redexim** parts for maintenance or repairs because of the safety of the machine *and* of the user.

Only authorised technical personnel may carry out repairs to the machine.

When carrying out maintenance, adjustments and repairs, it is necessary to block the machine in order to prevent it from sinking away, driving off and/or sliding off.

If a hydraulic installation is present, you should **always** make it pressure-free *before* working on this installation.

Used oil/grease is harmful to the environment. Dispose of these substances according to the regulations that apply in your location.

1.3. Using the machine

Attach the machine to the towing vehicle according to the regulations. Pay close attention to the risk of injury!

Never use the machine in the absence of protective guards and safety stickers.

Check the machine for loose bolts, nuts and components *before every operation.*

Check whether you have a clear field of vision – both close by and far away – *before* you start moving.

All persons that are going to operate the machine must be familiar with all the functions and control elements of the machine *before* starting any work activities.

Never crawl under the machine! If necessary, tip over the machine to work at the bottom side.

If present, check the hydraulic hoses regularly and replace these when the hydraulic hoses are damaged or appear old.

2. TECHNICAL DATA

<u>Type</u>	<u>TOP BRUSH 6000</u>
Recommended vehicle	40 pk with a minimum lifting capacity of 1000 Kg (2205 lbs) measured 610 mm behind the lifting eyes
Hydraulic connection of the tractor	2 x Double-acting valve Max. 60 l/min
Working width	6 m (236.2")
Working depth	5 – 20 mm (0.19" – 0.78")
Drive speed	Max. 15 km/h (9.3 mph)
Weight	613 kg (1352 lbs)
Dimensions (L x W x H)	
Wings down	1.5 x 6.19 x 0.93 m. (59.1" x 243.," x 36.6")
Wings up	1.5 x 2.23 x 2.72 m. (59.1 x 87.8" x 107.1")
Rotating speed of brushes	Max. 240 rpm
Three-point system	Cat. 1-2
Bearing grease to be used	EP 2
Tyre pressure	1 – 2 bar (14.5 – 29 Psi)



3. GENERAL DESCRIPTION

The TOP BRUSH is a machine that can be used for brushing, cleaning natural grass and can be used as a dew brush.

4. SAFETY STICKERS

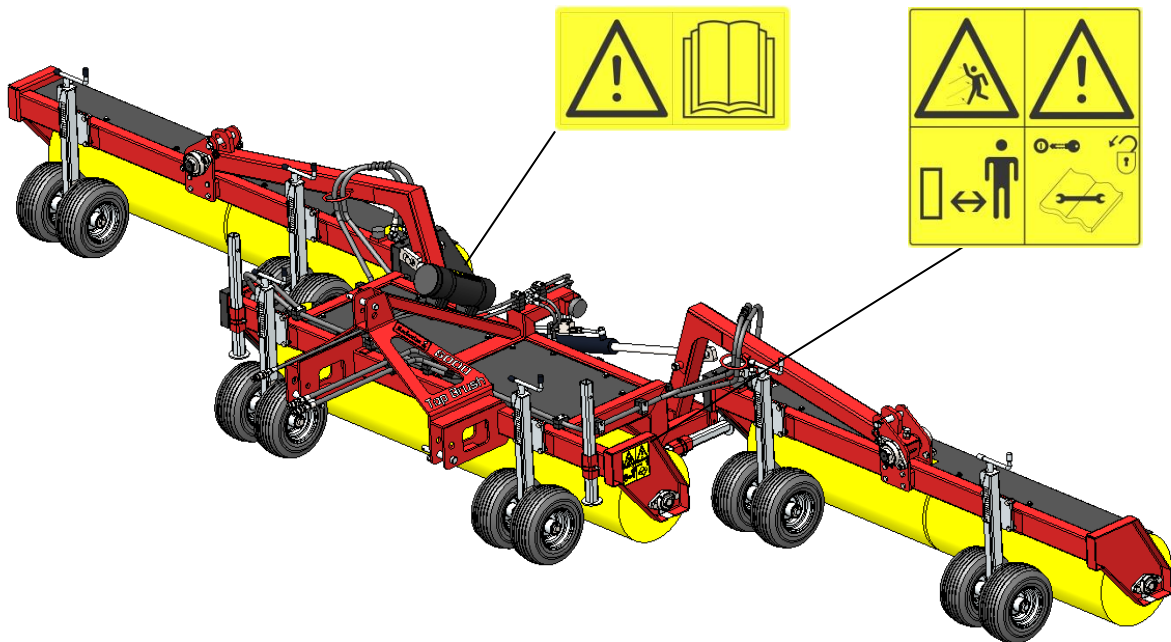
Safety stickers are located on both sides of the machine. These safety stickers must always be clearly visible and legible and must be replaced if they have become damaged.



 <p>933.280.402</p>	<ul style="list-style-type: none"> - In case of maintenance, adjustments and repair, always switch OFF the engine of the towing vehicle. - Keep a distance of minimum 4 metres if the machine is operating (except the operator).
 <p>900.280.402</p>	<ul style="list-style-type: none"> - Prior to using the machine, the operators of the machine must read the user manual carefully.

5. FIRST INSTALLATION

When the Top brush arrives, the machine is partly disassembled for transportation purpose. (Figure 1) Follow the next steps to remove the machine from the pallet and assemble the machine.

Before starting: make sure the pallet is stable and cannot slide during hoisting.

⚠ Ensure that the crane and hoisting cable can handle at least 1100 kg (2425 lbs).

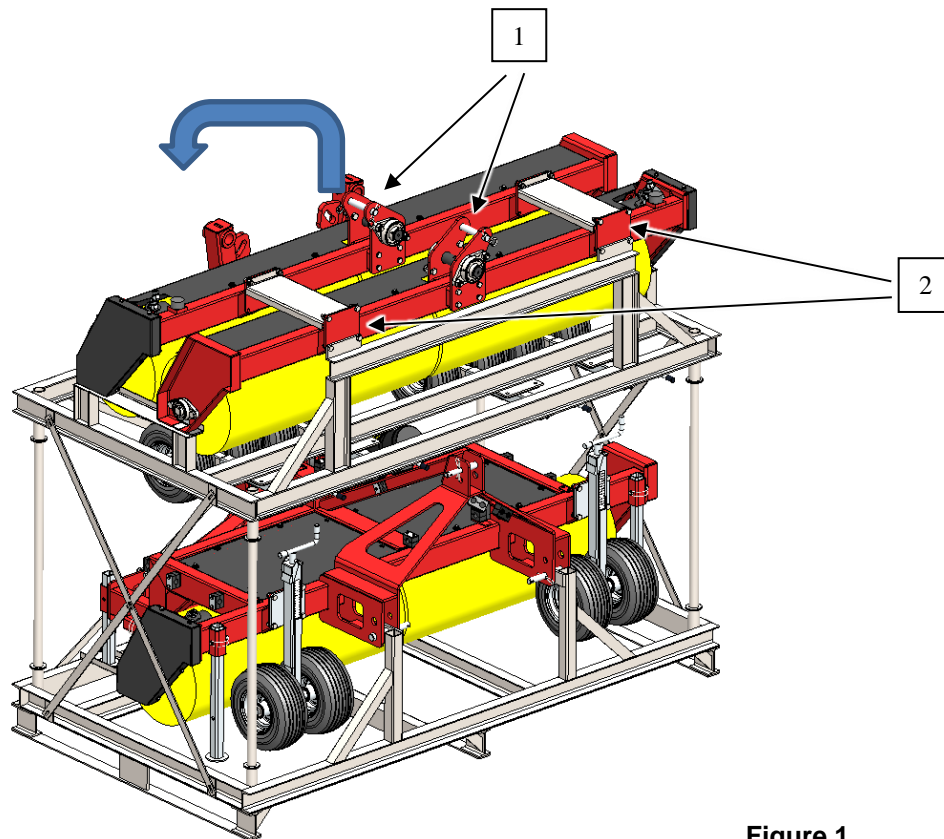
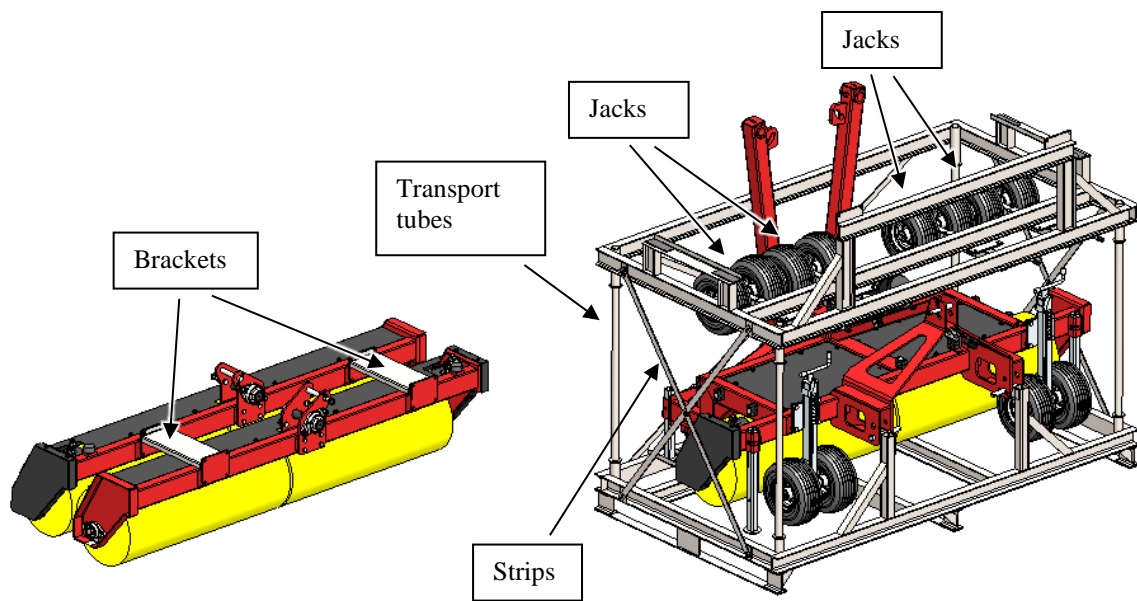

Figure 1

- 1) Attach cables to the hinge points (1) of the two brush sections and apply a small amount of tension.
- 2) Remove the bolts of the top frame (2).

⚠ !! KEEP A SAFE DISTANCE. THE MACHINE MAY START TO SLIDE DURING HOISTING !!
⚠ !! NEVER CRAWL UNDER THE MACHINE !!

- 3) Lift the two brush sections of the pallet and place these on the ground beside the pallet.



- 4) Remove the brackets between the two brush sections.
- 5) Remove the strips and top pallet and the four transport tubes.
- 6) Remove the four jacks from top pallet.

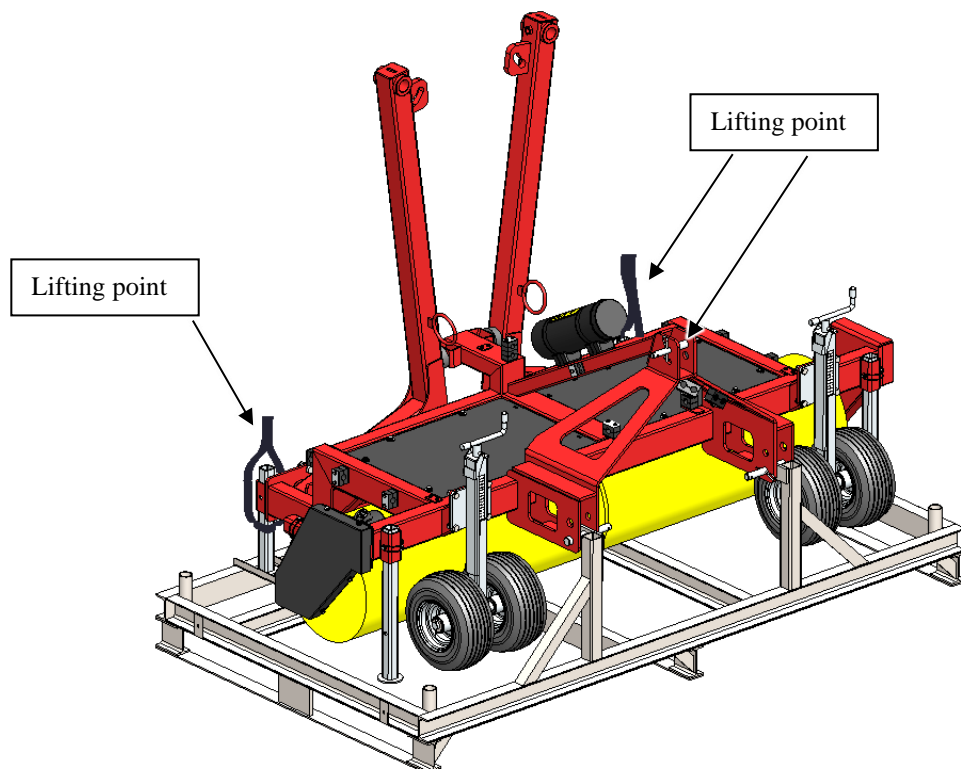

- 7) Remove the base unit from the pallet. Place a rope at the top 3-point and around the both rear legs as indicated in picture above.

- 8) Lower the left and right arms of the base unit.
- 9) Place the spindles on the left and right brush sections.

Attention!! Place the spindles with the hand grips 45 degrees (1) at the left brush and the spindles with the hand grips 90 degrees (2) on the right brush, see figure below.

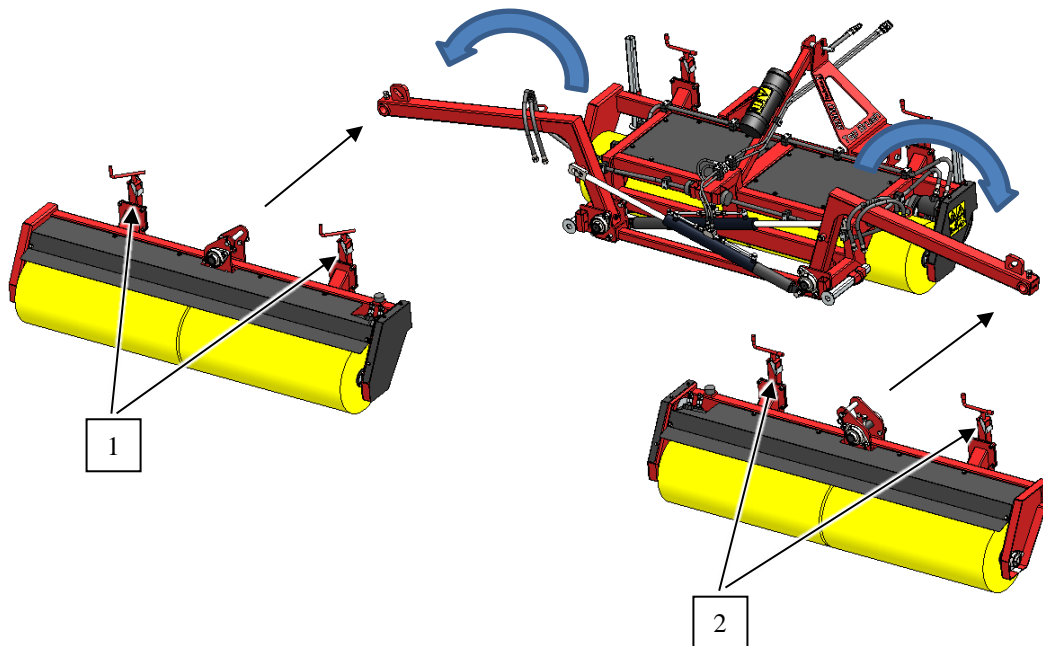

- 10) Place the left and right brush section behind the base unit and mount these on the left and right arms at the hinge points (1) and hinge block points (2), see figure below.

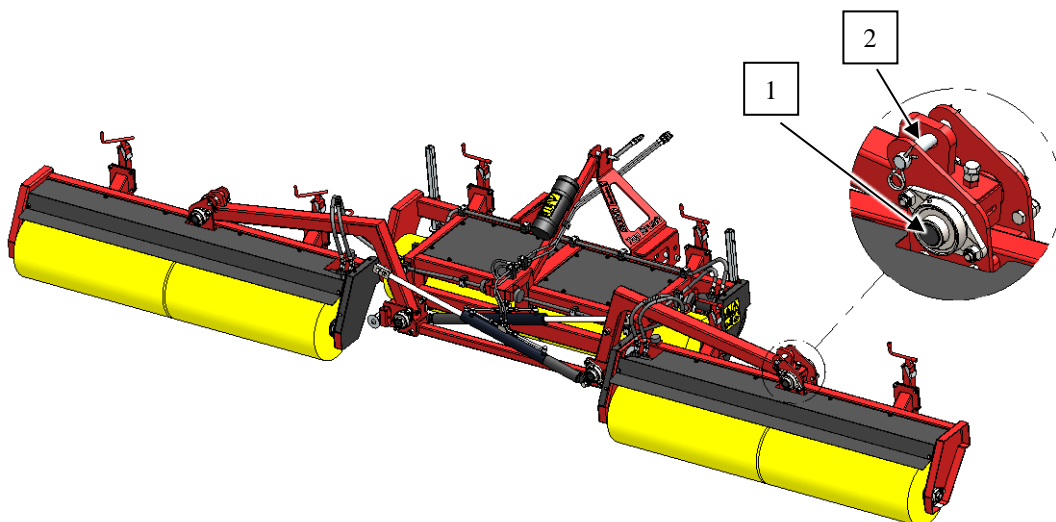

11) Mount the hydraulic hoses to the brush sections as shown in the pictures below.

Connect hose 1 to hydraulic motor point 1 as shown in detail 'A', connect hose 2 to hydraulic motor point 2 as shown in detail 'A' and detail 'B', connect hose 3 to hydraulic motor point 3 as shown in detail 'B'.

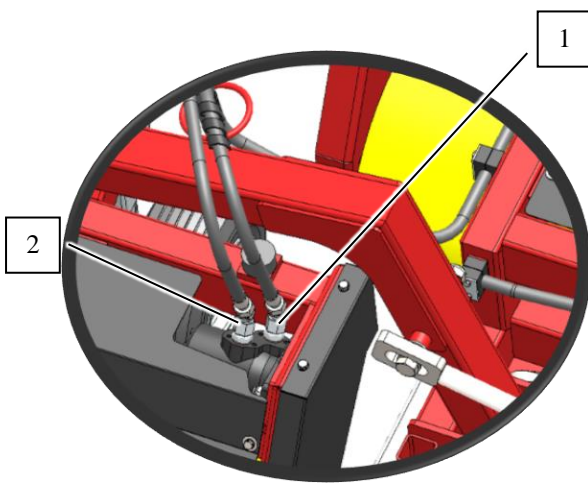
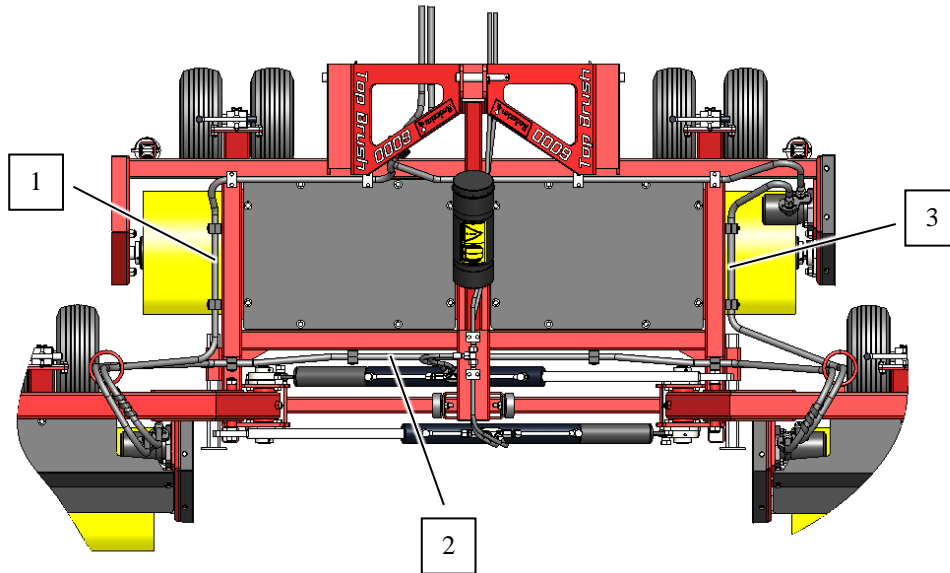

detail 'A'

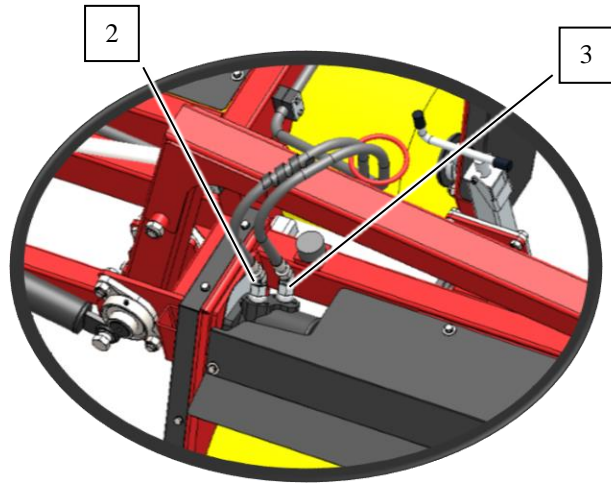

detail 'B'

6. ATTACHING AND DETACHING THE MACHINE

Attaching and detaching the machine has to be done carefully. Follow the instructions below:

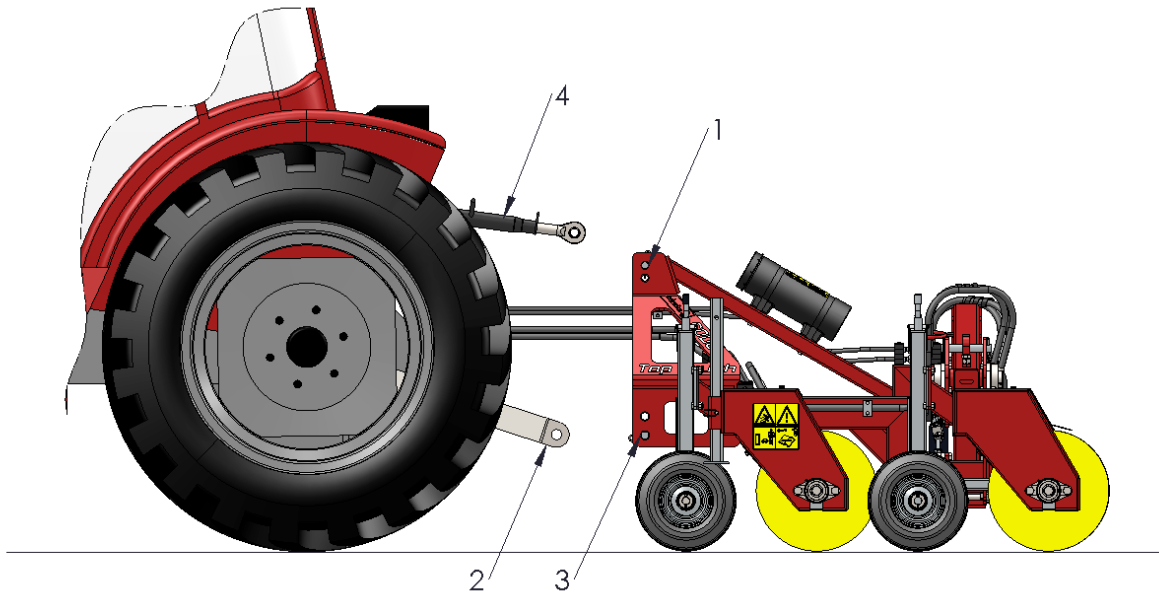

Figure 2

6.1. Attaching the machine

Prior to attaching the machine, check the following points:

- Check whether the machine is undamaged and whether it is safe to attach and use the machine.
- Check whether the bolts and nuts are tightened with the correct torque.
- Check whether all safety stickers are on the machine and whether these are undamaged and easily readable. **Never** use the machine if it has damaged or unreadable stickers.

The machine should be attached to the tractor in the following manner:

1. Remove the 3-point pins (1) at the top from the machine (see Figure 2).
2. Carefully drive the tractor backwards until the lifting arms (2) can be attached to the machine.



!! Make sure that the tractor and the machine cannot move while you are attaching them !!



!! Switch off the tractor engine before attaching the machine !!

3. Attach the lifting arms (2) to the machine using the 3-point pins (3). Lock the pins using the R-clips.
4. Set the stabilizer to a sideways stroke of 100 mm.
5. Mount the top rod (4) onto the tractor and attach it to the machine.
6. Adjust the top rod in such a manner that the machine is horizontal.
7. Connect hydraulic hoses to the tractor.



!! Make sure that the 3-point pins are locked using the R-clips !!

8. Start the tractor and lift the machine off the ground.

6.2. Detaching the machine

The machine should be detached in the following manner (see Figure 2):

1. Place the tractor and the machine on a flat surface.



!! Make sure that the machine and the tractor cannot move while you are detaching them !!



!! Switch off the tractor engine *before* detaching the machine !!

2. Lower the front and back legs.
3. Carefully place the machine on the ground.
4. Loosen the top rod (4) and remove it.
5. Disconnect the lowest arms (2).
6. Disconnect the hydraulic hoses from the tractor



!! The ground must be flat !!

7. Start the tractor and drive off.

7. MACHINE SETTINGS

The TOP BRUSH depth can be adjust manually by turning the wheels up or down (see Figure 3):

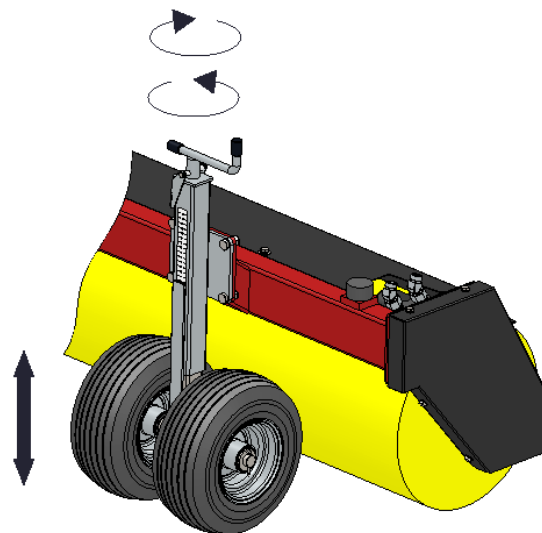

Figure 3

8. TRANSPORT

The user is responsible for transporting the TOP BRUSH in back of the tractor on public roads. Verify the national legislation regarding the regulations. On open fields while the machine is raised, the maximum permitted speed is 20 km/h (12.4 mph) due to the weight of the TOP BRUSH. A higher speed can be dangerous for the driver and/or the public and can even damage the machine.



!! When the machine is raised off the ground, the front axle of the tractor has to support minimum 20% of the tractor's weight !!

9. START/STOP PROCEDURE

9.1. Safety

Before using the TOP BRUSH, you should check the following:

1. Are there loose objects in the field? First remove these objects.
2. Are there slopes? The maximum slope for this machine is 20 degrees.
3. Are there hard objects in the ground? If so, use the TOP BRUSH at adjusted speed.
4. Is there danger of flying objects (e.g., golf balls) that distract the attention of the driver? If so, the TOP BRUSH **CANNOT** be used.
5. Is there danger of sinking/sliding away? If so, postpone the work.
6. If the soil is frozen, postpone the activities until conditions improve.
7. Do NOT make sharp turns when the TOP BRUSH touches the ground.

9.2. Starting to brush

Prior to brushing using the machine, check the following points:



!! Make sure that the TOP BRUSH and the tractor cannot move while you are setting them !!



!! Switch off the tractor engine *before* getting of the tractor !!

- Check the brushes for damage and repair these if necessary.
- Check the machine on loose parts.
- Make sure the hydraulics are connected in the right way.

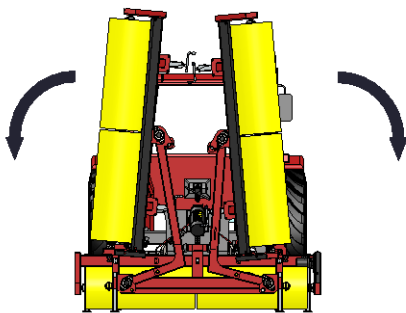

Figure 4

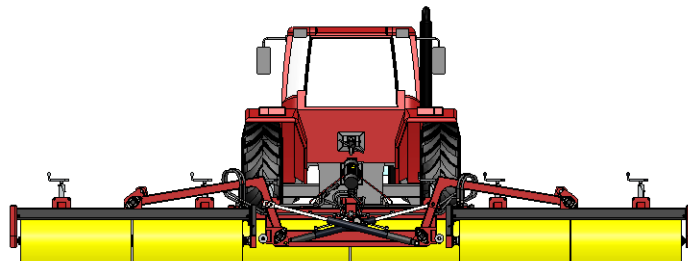

Figure 5

The start procedure is **VERY** important. Follow the next procedure, because otherwise the TOP BRUSH can get damaged.

1. Drive to a spot where the machine will be used.
2. Lower the wings (figure 4) of the TOP BRUSH slowly until they completely down (figure 5).
3. Switch on the hydraulics so that the brushes will turn.



!!Choose the right rotation of the brushes. There are two ways in which you can work, against or in direction of travel!!

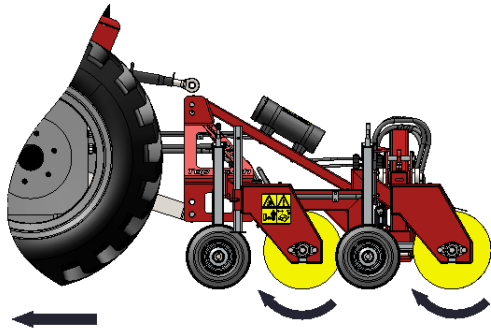

Against the direction of travel

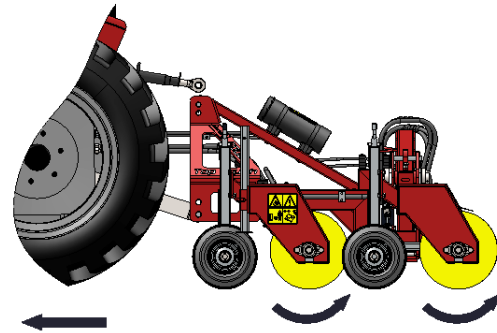

with the direction of travel

4. Drive slowly forwards and lower the machine till the machine is on the ground
5. Increase the speed to the required speed.



!! The maximum working speed is 15 km/h. Higher speeds are not recommended and can cause damage to the TOP BRUSH !!

9.3. Stop brushing

1. Reduce the speed.
2. Lift the machine off the ground.
3. Switch the hydraulic for brushing off.
4. Lift the wings.
5. Drive to the next spot and start all over.

10. MAINTENANCE

Time schedule	Check / Grease point	Method
Before every use	Check for loose bolts / nuts.	Tighten loose bolts / nuts.
	Presence and readability of the safety stickers	Replace these if not present or damaged.
After every use	Clean the machine.	Use air or water to clean the machine.
After the first 20 working hours (new or repaired)	Check for loose bolts / nuts.	Tighten loose bolts / nuts.
	Provide the lubrication points with grease.	Use EP2 grease 1 shot
	Check whether the drive chains are greased adequately.	Grease the drive chains.
After every 100 hours	Check whether the drive chains are greased adequately.	Grease the drive chains.
	Provide the lubrication points with grease.	Use EP2 grease

Table 1

10.1. Lubrication points

To guarantee the proper functioning of the TOP BRUSH, the lubrication points at both sides of the machine (see Figure 6) must be greased periodically. Grease these points according to Table 1.

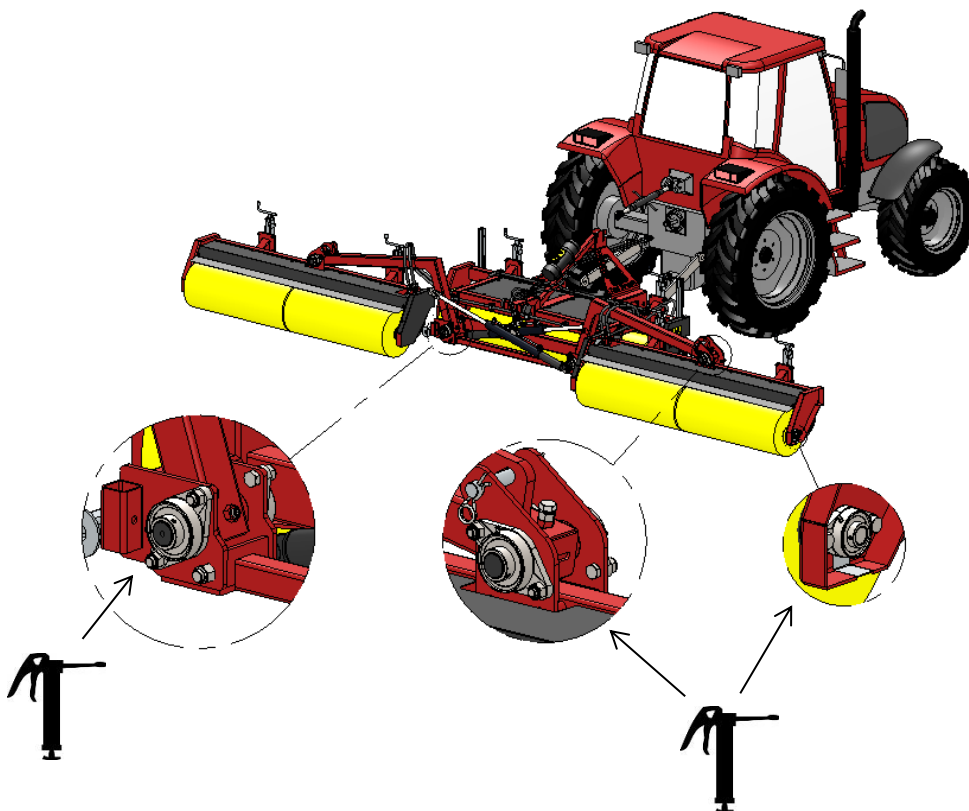

Figure 6

11. TROUBLE SHOOTING (PROBLEM ANALYSIS)

Problem	Possible cause	Solution
The tractor does not have sufficient traction.	Soil is too wet	Postpone the operation
The brushes bounce over the field	Drive too fast	Lower drive speed
The soil is damaged	Working depth is too deep	Adjust the machine to less depth
	Wrong rotation of the brushes	Try other direction of rotation of the brushes
Too little cleaning	Working depth is adjusted too shallow	Adjust the machine to more depth
	Brush is full	Clean the brush
	Subsoil is too hard	Drive along a few more steps while adjusting to more depth every time
Sloppy image of the field after processing	Machine is adjusted too deep	Adjust the machine to less depth
	Brush does not touch the ground	Adjust the machine to more depth
	Brush is damaged	Replace or repair the brush

12. OPTION: SECURITY CHAIN FOR TRANSPORT

A security chain is available to transport the Top Brush safely on the road (see Figure 7).

This can be ordered under number: 490.074.700



!! When working with the Top Brush, the security chain must be stored in the toolbox on the base unit. !!

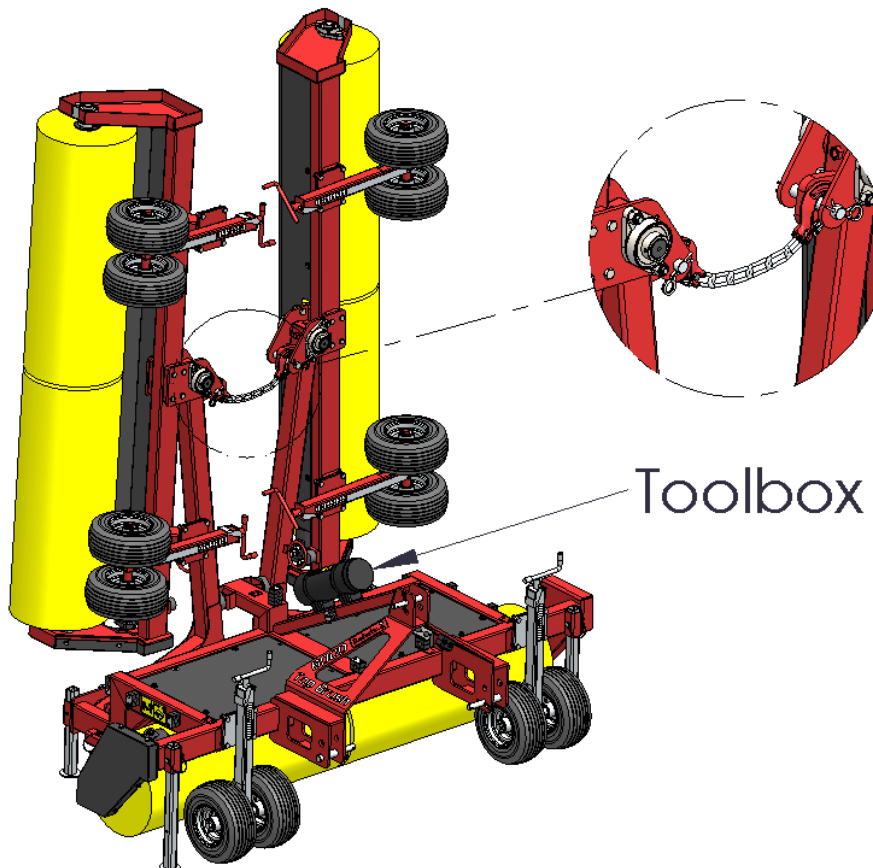

Figure 7