

MULTI-SPORT

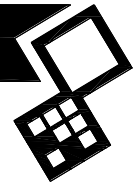

Translation of the original user manual





2213 English 961.120.000 EN

FOREWORD

Congratulations on your Multi-Sport purchase! For safe and long-lasting operation of this Multi-Sport, it is necessary to read and to understand this user manual. It is impossible to work safely with this machine *without* complete knowledge of its content.

The Multi-Sport is not a machine that works independently. It is the user's responsibility to use the correct tractor. The user must also check the tractor/Multi-Sport combination on safety aspects such as noise level, user instructions and risk analysis.

The following pages deal initially with the general safety instructions. Every user should know these safety instructions and apply them. At the end of this page, a registration card is inserted. This registration card should be returned to enable us to deal with potential future claims.

This user manual lists many instructions that are numbered in sequence. You should follow this sequence. A  is an indication of a safety instruction. A  means a tip and/or note.

All information and technical specifications provided at the moment that this document is published are the most recent ones. Design specifications may be changed without prior notice.

This document is a translation of the original operating instructions. Upon request, the original operating instructions are available in Dutch.

WARRANTY CONDITIONS

WITH DELIVERY THIS MULTI-SPORT IS GUARANTEED AGAINST MATERIAL DEFECTS. THIS WARRANTY IS VALID FOR A PERIOD OF 12 MONTHS FROM THE PURCHASE DATE.

MULTI-SPORT WARRANTIES ARE SUBJECT TO THE 'GENERAL CONDITIONS FOR SUPPLY OF PLANT AND MACHINERY FOR EXPORT, NUMBER 188' THAT ARE PUBLISHED UNDER THE AUSPICES OF THE UNITED NATIONS ECONOMIC COMMISSION FOR EUROPE.

REGISTRATION CARD

For your own information, fill in the table below:

Serial number machine	
Dealer name	
Date of purchase	
Remarks	

SAFETY INSTRUCTIONS

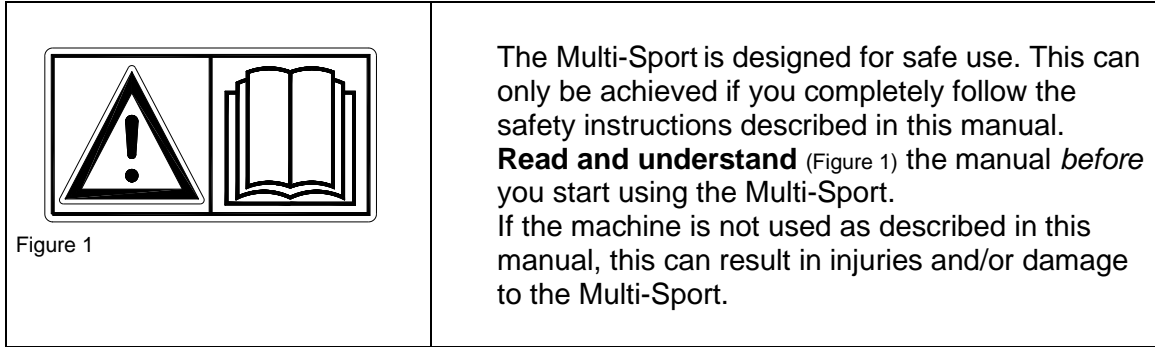

1. The user must be an expert in using the machine. The machine should be professionally adjusted for cultivating the subsoil.

The manufacturer will not accept any liability for unprofessional use and its resulting damage. All risks occurring with this are entirely at the expense of the user. Not following the use, maintenance and repair instructions prescribed by the manufacturer is also considered improper/unprofessional use of this machine.

Inspect the area to be treated *before* using the Multi-Sport.
Remove loose obstacles and avoid irregularities.

2. The Multi-Sport is manufactured according to the latest technical understanding and is safe to use.

When careless people use, maintain or repair the machine, danger of injuries to the user *and* to third parties can be the result. **This must be avoided!**

Always use the Multi-Sport in combination with the correct tractor as described in the technical data.

3. All persons assigned to operate, maintain and repair the Multi-Sport by the owner must completely read and understand the operation manual and in particular the chapter of **Safety Instructions**.

The user is responsible for a **safe Tractor/Multi-Sport combination**. **This entire combination must be tested** on noise, safety, risk and user friendliness. User instructions should also be drafted.

4. The user is **obliged to check** the Multi-Sport for **visible damage and defects** before using the Multi-Sport.
Modifications to the Multi-Sport (including its operations) that have a negative impact on safety must be rectified immediately.
For safety reasons it is in principle not permitted to make changes or adjustments to the Multi-Sport (except those approved by the manufacturer).

If **modifications** to the Multi-Sport have been made, then the current CE marking is cancelled. The person that has made these modifications has to apply for a new **CE marking himself**.

Check the Multi-Sport for loose bolts, nuts and components *before* every operation.

NEVER use the Multi-Sport in the absence of the safety stickers.

NEVER crawl under the Multi-Sport.
If necessary, tilt the Multi-Sport.

NEVER step off the tractor while the motor is running.

In case of maintenance, adjusting and repairs, it is necessary to block the Multi-Sport in order to prevent sinking away, driving off and/or sliding off.

Always switch off the tractor motor and take the tractor's key out off the ignition in case of maintenance, adjusting and repairs (Figure 2).

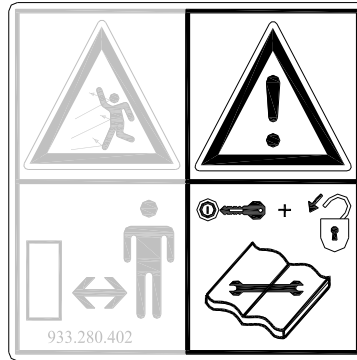

Figure 2

With regards to the safety of the machine and the user, use only original Multi-Sport parts for maintenance and repairs.

Only authorised technical personnel may carry out repairs to the **Multi-Sport**.

Keep a record of the repair activities.

5. The general applicable health & safety (Dutch acronym: ARBO) regulations must also be followed in addition to the instructions in this user manual.

Relevant traffic regulations also apply in case of using public roads.

Transporting persons is not permitted!

Do not use the Multi-Sport in the dark, in heavy rain/storm or on slopes with an angle larger than 20 degrees.

6. All persons that are going to operate the Multi-Sport must be familiar with all the functions and control elements of the Multi-Sport *before* starting any work activities.

Attach the Multi-Sport to the towing vehicle according to the regulations.

(Danger of injuries!)

Check whether you have a clear field of vision – both close by and far away – *before* you depart.

Safety stickers (Figure 2, 3 and 4) with an identical meaning are attached to the sideboards (Figure 5) of the Multi-Sport. These safety stickers must always be clearly visible and legible and must be replaced in case they have become damaged.

During operation, **NO persons are allowed within the danger zone** of the Multi-Sport, because there is danger of physical injuries caused by flying particles or substances (Figure 3).



Figure 3



Figure 4

Keep a distance of minimum 4 metres (Figure 4)!

Pay attention to the permitted lifting capacity of the towing vehicle.

Dress appropriately. Wear sturdy shoes with steel toecaps, long trousers and tie up long hair. Do not wear loose clothing.

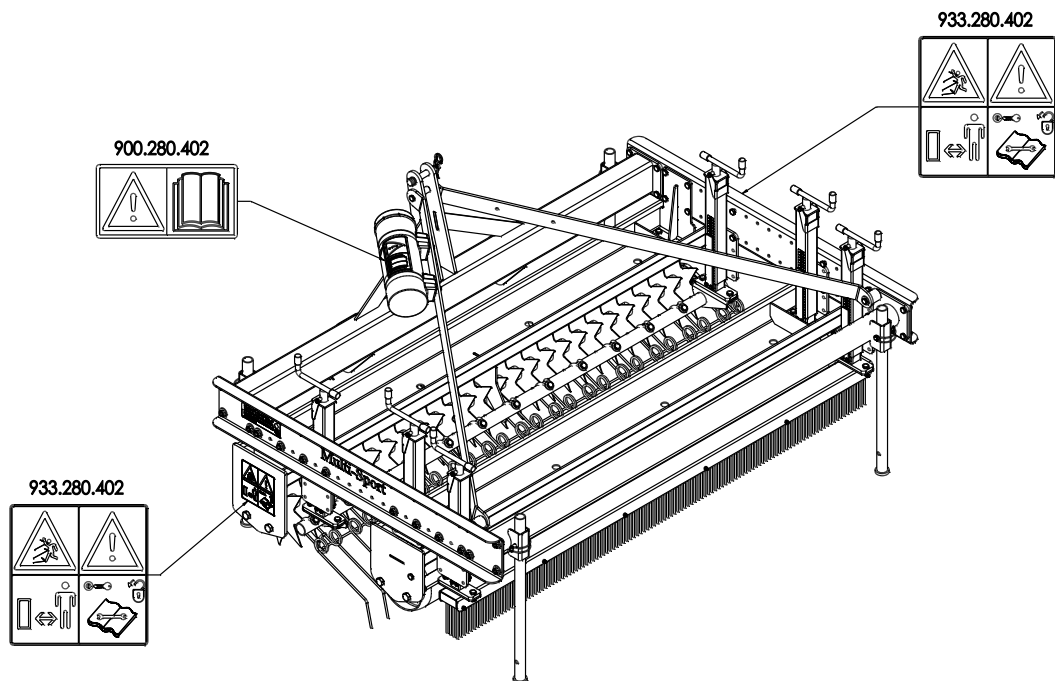

Figure 5

7. Location of the safety stickers (Figure 5)



EU DECLARATION

We,

**Redexim BV
Utrechtseweg 127
3702 AC Zeist, The Netherlands**

declare completely under our own responsibility that the product:

**MULTI-SPORT WITH MACHINE NUMBER AS INDICATED ON THE MACHINE
AND IN THIS MANUAL,**

to which this declaration refers, complies with stipulation of the 2006/42/EC machine directive and is in conformity with the following standards: NEN-EN-ISO 12100 : 2010
NEN-EN-ISO 13857 : 2008

Zeist, 08/02/2016

A.C. Bos
Manager Operations & Logistics
Redexim Holland

TABLE OF CONTENTS

FOREWORD.....	2
WARRANTY CONDITIONS.....	2
REGISTRATION CARD.....	2
SAFETY INSTRUCTIONS	3
EU DECLARATION	6
1. TECHNICAL DATA	8
2. FIRST INSTALLATION – TAKING THE MACHINE OUT OFF THE BOX	9
3. LIST OF GENERAL COMPONENTS.....	9
4. ATTACHING THE MACHINE TO THE TRACTOR	10
5. SETTING THE DIFFERENT SECTIONS AND OPERATIONAL AGGRESSIVENESS	11
6. TRANSPORTING THE MULTI-SPORT.....	11
7. DRIVING SPEED.....	11
8. USING THE MULTI-SPORT	12
9. START/STOP PROCEDURE	12
10. DETACHING THE MULTI-SPORT	13
11. TROUBLE SHOOTING (PROBLEM ANALYSIS).....	14
12. MAINTENANCE	14
13. CHANGING THE SPRING PINS.....	15

1.0 TECHNICAL DATA

<u>Model</u>	<u>1800</u>
Working width	1.8 m (71")
Working depth	Surface processing
Speed	Maximum 12 km/h (7.5 mph)
Weight	325 kg (716 lbs)
Recommended tractor	18 HP with minimum lifting capacity of 400 kg (880 lbs)
Maximum capacity (Theoretical at maximum speed of 12 km/h [7.5mph])	21600 m ² /h (232416 ft ² /h)
Transport dimensions	L x W x H 1300 x 1930 x 950 mm 51" x 76" x 37.5"
Three-point connection	Cat. 1-2
Grease	EP 2
Standard components	Rotor section Rake section Roller section Brush section 4 Legs for storage the machine Toolbox including a manual
Optional	none

2.0 FIRST INSTALLATION – TAKING THE MACHINE OUT OFF THE BOX

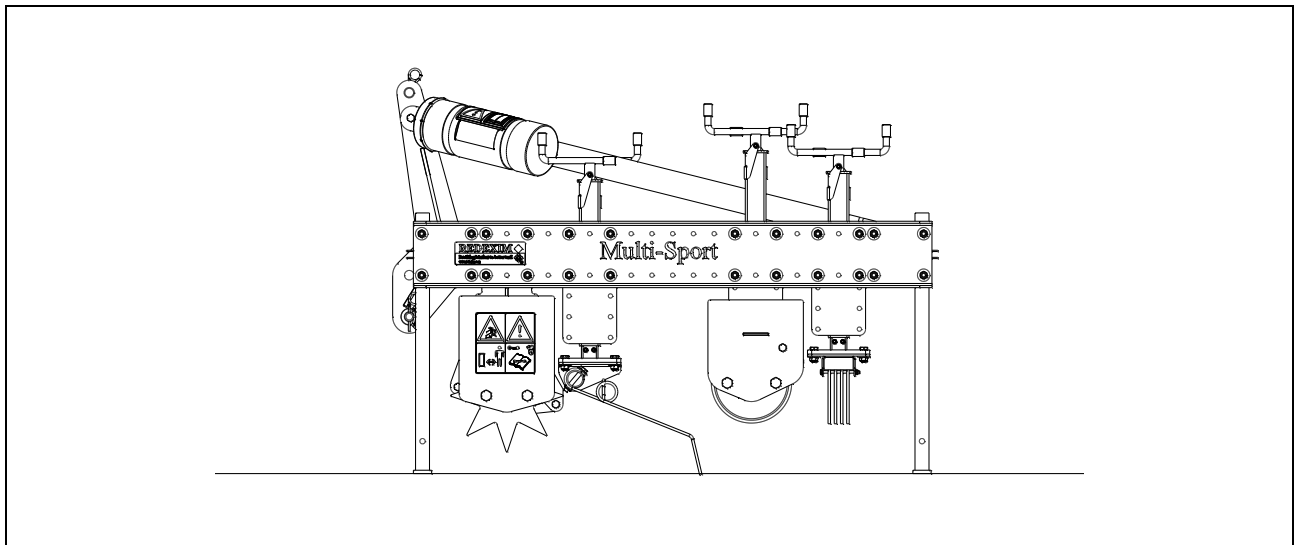

Figure 6

The machine is delivered in a box. For assembling the machine see parts manual. After assembling, the machine look like picture above. (see Figure 6)

 **NEVER crawl under the machine!**

3.0 LIST OF GENERAL COMPONENTS

Figure 7 shows several important components:

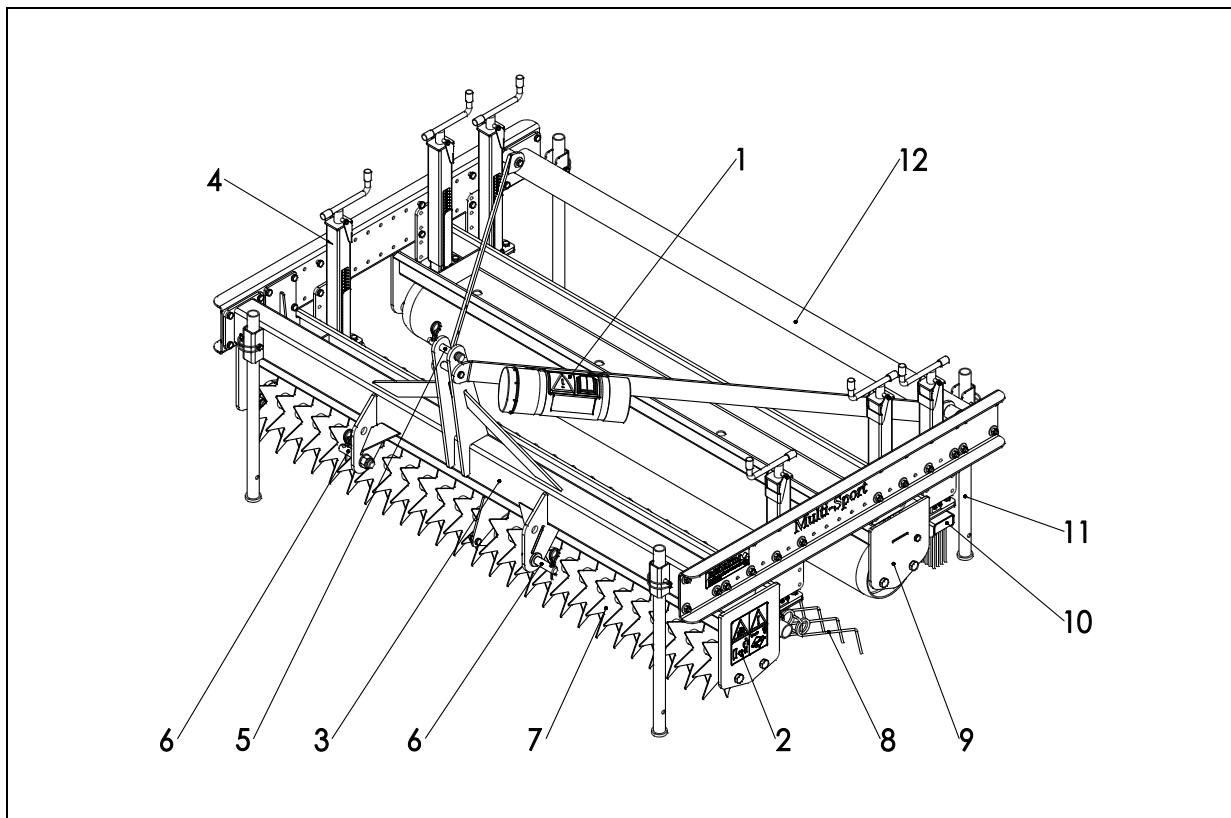

Figure 7

1. Safety sticker 900.280.402; first read the user manual / toolbox including a manual before using it.
2. Safety sticker 933.280.402; keep a minimum distance of 4 metres from the machine. Stop the motor if repair or adjustment is needed. Watch out for flying particles and substances!

⚠ All the safety stickers should be on the machine at all times and should be understood.

3. The serial number is located at the front side of the machine.
4. Spindles for setting the working depth
5. Upper 3-point connection
6. Bottom 3-point connection
7. Rotor section
8. Rake section
9. Roller section
10. Brush section
11. Legs for storage
12. Base frame

4.0 ATTACHING THE MACHINE TO THE TRACTOR

Checking procedure before starting to attach the Multi-Sport.

- Check the Multi-Sport for visually discernable damage and repair this if safe operation of the machine is no longer guaranteed.
- Check whether all the nuts and bolts are tight.
- Check whether all safety stickers are present on the machine and are not damaged.

NEVER use the machine without these items.

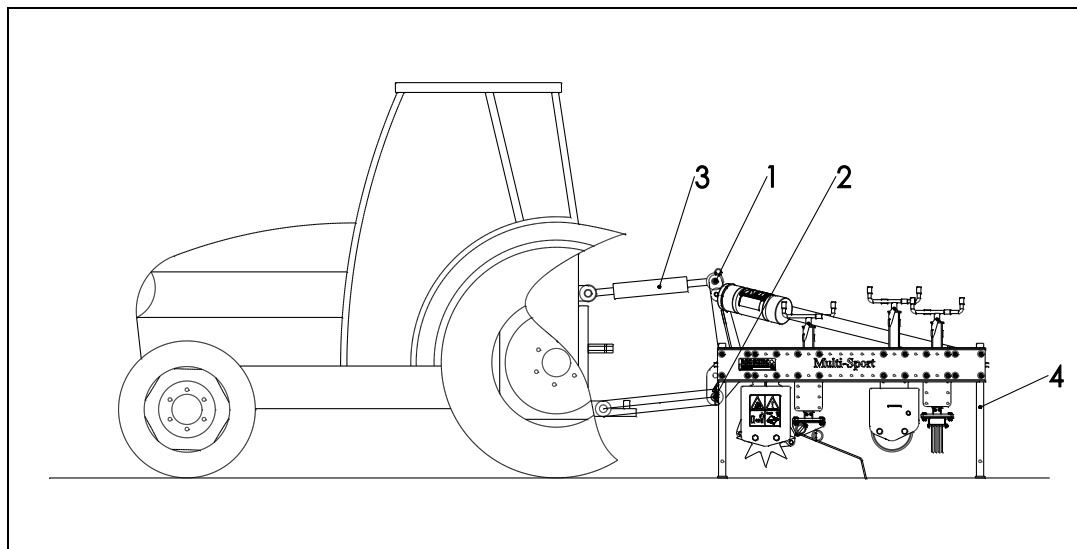

Figure 8

The Multi-Sport can be attached to the tractor by means of the 3-point attachment.

The procedure is as follows (see Figure 8):

1. Remove the 3-point pins (1 and 2).
2. Drive the tractor carefully backwards so that the lower connecting arms can be attached to the frame.

 **Make sure that the tractor is blocked well and cannot move on its own accord!**

 **Switch off the tractor before descending!**

3. Connect the lower connecting arms to the 3-point pins (2) and secure these with the supplied locking pins.
4. Set the stabilizer of the tractor to 100 mm lateral stroke.
5. Mount the top rod (3) of your tractor and turn it outward until it reaches the same height as the 3-point stop connection of the Multi-Sport.
6. Connect the top rod (3) to the frame with the pin (1); secure the pin (1) with the supplied locking pin.
7. Turn the top rod (3) inwards so that it becomes pressurized.

 **Make sure that all the securing pins are locked!**

8. Start the tractor and lift the Multi-Sport off the subsoil.
9. Lift stand legs (4)

5.0 SETTING THE DIFFERENT SECTIONS AND OPERATIONAL AGGRESSIVENESS

The different sections and aggressiveness can be set with the spindles:

1. By turning the spindles (4) (Figure 7) the different sections can be placed in upper or lower position on the machine. More configurations are possible.
Notice that both sides of the machine adjust at the same height so that it is possible to process the field as evenly as possible.

NEVER adjust the machine in such a way that it could damage the subsoil or the machine.

 **IMPORTANT! First check the working depth on the subsoil statically *before* using the machine!**

6.0 TRANSPORTING THE MULTI-SPORT

The user is responsible for transporting the Multi-Sport attached to the tractor over public roads. Verify the national legislation regarding the regulations.

On open fields while the machine is raised, the maximum permitted speed is 12 km/h (7.5 mph) due to the weight of the Multi-Sport.

A higher speed can be dangerous for the driver and/or the public and can even damage the machine.

 **When the machine is raised off the ground, the front axle of the tractor has to support minimum 20% of its weight.**

7.0 DRIVING SPEED

The driving speed is limited to 12 km/h (7.5mph).

It is NOT recommended to drive faster due to the fact that excessive wear & tear and damage can occur to the machine and to the subsoil.

8.0 USING THE MULTI-SPORT

Before using the Multi-Sport on a location, you should check the following items:

1. Are there loose objects in the field? First remove these objects.
2. Are there slopes? The maximum slope is 20 degrees for the Multi-Sport.
3. Always go from top to bottom.
Is there danger of flying objects (e.g., golf balls) that distract the attention of the driver? If so, the Multi-Sport **CANNOT** be used.
4. Is there danger of sinking/sliding away? If so, postpone the processing until conditions improve.
5. A field can be worked several times in the same or different directions in order to obtain better processing.
6. Do not make sharp bends and preferably, drive in straight lines; otherwise you might damage the machine and the subsoil.
7. Do not set the machine in a too aggressive mode; this can lead to undesired damage of the subsoil and additional wear and tear of the teeth.

9.0 START/STOP PROCEDURE

The start procedure is **VERY** important. If this procedure is not executed as described below, serious damage to the subsoil could be the result.

The start procedure is as follows:

1. Check the Multi-Sport for loose components and look whether all components function properly.



If loose components are observed or components do not function properly, the problems must be solved *before* using the Multi-Sport!

2. Drive to the spot where the processing should take place.
3. Turn the top rod (3) so that the machine stands perpendicular to the subsoil (see Figure 8).
4. Set the aggressiveness of the machine statically as described in Chapter 5.0.



Make sure that the tractor is blocked well and cannot move on its own accord! Switch off the tractor before descending!

5. Let the machine drop until the machine hovers above the ground at approx. 50 mm.
6. Engage the tractor in the correct gear.
7. Set the tractor in forward motion and let the Multi-Sport sink onto the pre-adjusted bearing rollers with a smooth movement.
8. Increase the driving speed to maximum 12 km/h (7.5 mph).

Stopping occurs as follows:

1. While driving, lift the machine with a smooth movement.
2. Drive to the next location and start the operation as described above.

10.0 DETACHING THE MULTI-SPORT

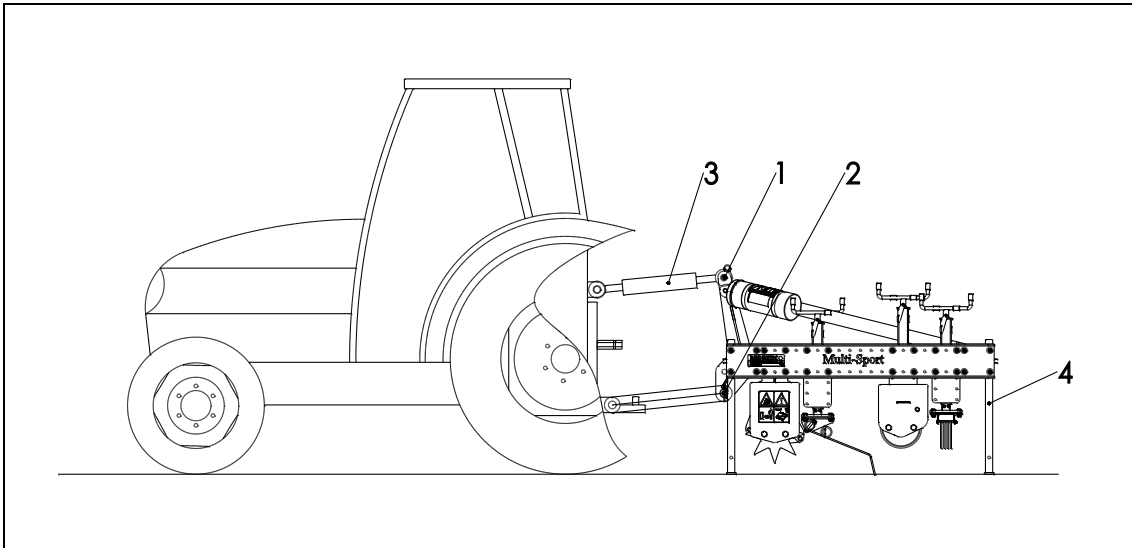

Figure 9

The machine can be detached from the tractor in the following manner (See Figure 9):

1. Drive the Multi-Sport to a parking area with a firm/flat surface.

⚠ Make sure that the tractor is blocked well and cannot move on its own accord!

⚠ Switch off the tractor before descending!

2. Place the legs (4) in the lower position.
2. Carefully drop the Multi-Sport to the subsoil.
3. Release the top rod (3).
4. Take the locking pin out of the pin (1) and pull the pin out of the top rod connection.
5. Pull the locking pins out of the pins (2) and remove the pins.

⚠ Make sure that the Multi-Sport stands stable!

6. Start the tractor and drive off.

11.0 TROUBLE SHOOTING (PROBLEM ANALYSIS)

Problem	Possible cause	Solution
Too little cleaning	Working depth is adjusted too shallow	Adjust the machine to more depth
	Subsoil is too hard	Drive along a few more steps while adjusting to more depth every time
	Teeth are not sufficiently aggressive	Set the machine to a more aggressive angle
Sloppy image of the field after processing	Machine is adjusted too aggressively	Adjust the machine to a mode that is less aggressive
	Subsoil is too wet	Wait for better conditions

13.0 MAINTENANCE

Time schedule	Check/Grease point	Method
Before every use	Check for loose bolts/nuts	Tighten loose bolts/nuts with the correct tightening moment
	Presence and readability of the safety stickers (Please refer to Figure 5)	Replace these if not present or damaged

14.0 CHANGING THE SPRING PINS

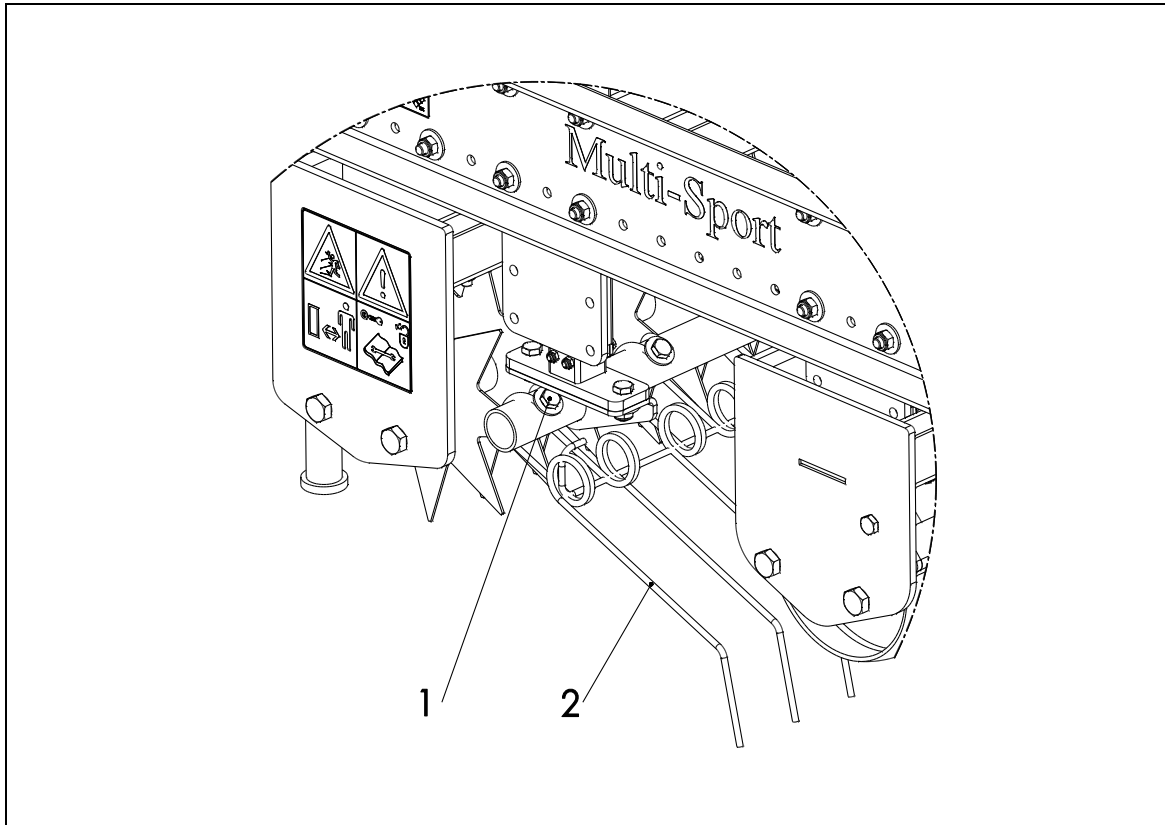

Figure 10

A rake is mounted on the Multi-Sport. This rake consists of a tube frame equipped with spring pins.
Depending on the use of the machine, wear & tear or breaking of the spring pins can occur. This might mean that you will have to replace the spring pins at a certain point.

Replacing the spring pins is done as follows (see Figure 10):

⚠ Make sure that the Multi-Sport is blocked well and cannot move on its own accord!

1. Loosen bolt(s) and nut(s) (1) a single turn.
2. Remove the rope
2. Remove the spring pin(s) (2) replace these with new ones.
3. Tighten bolt(s) and nut(s) (1).
5. Reattach the rope.