

# User Manual and Parts Book of the Verti-Top® Tow Behind

**Serial number:**

**REDEXIM**

Kwekerijweg 8  
3709 JA Zeist  
the Netherlands  
T: (31)30 6933227  
F: (31)30 6933228  
E: [verti-drain@redexim.com](mailto:verti-drain@redexim.com)  
[www.redexim.com](http://www.redexim.com)



Translation of the original operating  
instructions

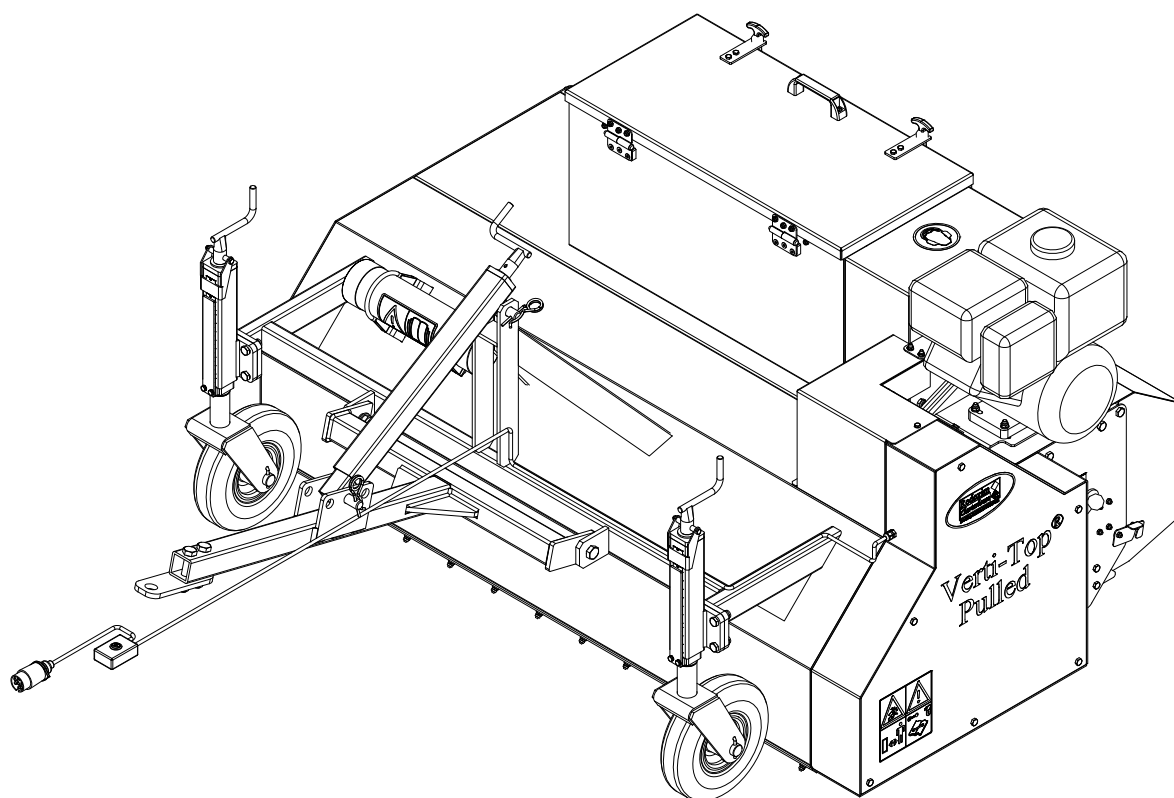



**ATTENTION:**  
IT IS OF THE UTMOST IMPORTANCE TO READ THIS USER MANUAL  
CAREFULLY PRIOR TO USING THE VERTI-TOP TOW BEHIND IN ORDER TO  
USE THE MACHINE SAFELY AND TO OBTAIN THE BEST RESULTS.

## FOREWORD

Congratulations on your Verti-Top Tow Behind purchase! For safe and long-lasting operation of this Verti-Top Tow Behind, it is necessary to read and to understand this user manual. It is impossible to work safely with this machine *without* complete knowledge of its content.

The Verti-Top Tow Behind is not a machine that works independently. It is the user's responsibility to use the correct towing vehicle. The user must also check the towing vehicle/Verti-Top Tow Behind combination on safety aspects such as noise level, user instructions and risk analysis.

The following pages deal initially with the general safety instructions. Every user should know these safety instructions and apply them. At the end of this page, a registration card is inserted. This registration card should be returned to enable us to deal with potential future claims.

This user manual lists many instructions that are numbered in sequence. You should follow this sequence. A  is an indication of a safety instruction. A  means a tip and/or note.

All information and technical specifications provided at the moment that this document is published are the most recent ones. Design specifications may be changed without prior notice.

This document is a translation of the original operating instructions. Upon request, the original operating instructions are available in Dutch.

## WARRANTY CONDITIONS

WITH DELIVERY THIS VERTI-TOP TOW BEHIND IS GUARANTEED AGAINST MATERIAL DEFECTS.

THIS WARRANTY IS VALID FOR A PERIOD OF 12 MONTHS FROM THE PURCHASE DATE. VERTI-TOP TOW BEHIND WARRANTIES ARE SUBJECT TO THE 'GENERAL CONDITIONS FOR SUPPLY OF PLANT AND MACHINERY FOR EXPORT, NUMBER 188' THAT ARE PUBLISHED UNDER THE AUSPICES OF THE UNITED NATIONS ECONOMIC COMMISSION FOR EUROPE.

## REGISTRATION CARD

For your own information, fill in the table below:

Serial number of the machine	
Dealer name	
Date of purchase	
Remarks	

## SAFETY INSTRUCTIONS

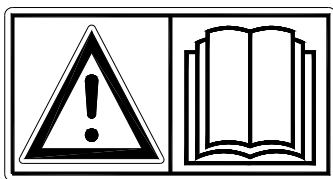

Figure 1

The Verti-Top Tow Behind is designed for safe use. This can only be achieved if you completely follow the safety instructions described in this manual.

**Read and understand** (Figure 1) the manual *before* you start using the Verti-Top Tow Behind. If the machine is not used as described in this manual, this can result in injuries and/or damage to the Verti-Top Tow Behind.

1. The user must be an expert in using the machine. The machine should be professionally adjusted for cultivating the subsoil.

The manufacturer will not accept any liability for unprofessional use and its resulting damage. All risks occurring with this are entirely at the expense of the user. Following the use, maintenance and repair instructions prescribed by the manufacturer is also considered professional use of this machine.

Inspect the area to be treated *before* using the Verti-Top Tow Behind. Remove loose obstacles and avoid irregularities.

2. The Verti-Top Tow Behind is manufactured according to the latest technical understanding and is safe to use.

When unskilled people use, maintain or repair the machine, this could result in injuries to the user *and* to third parties. **This must be avoided!**

Always use the Verti-Top Tow Behind in combination with the correct towing vehicle as described in the technical data.

3. All persons assigned to operate, maintain and repair the Verti-Top Tow Behind by the owner must completely read and understand the operation manual and in particular the chapter of **Safety Instructions**.

The user is responsible for a **safe towing vehicle/Verti-Top Tow Behind combination**. **This entire combination must be tested** for noise, safety, risk and user friendliness. User instructions should also be drafted.

4. The user is **obliged to check** the Verti-Top Tow Behind for **visible damage and defects** before using the Verti-Top Tow Behind. Modifications to the Verti-Top Tow Behind (including its operations) that have a negative impact on safety must be rectified immediately. For safety reasons it is in principle not permitted to make changes or adjustments to the Verti-Top Tow Behind (except those approved by the manufacturer).

If **modifications** to the Verti-Top Tow Behind have been made, then the current CE marking is cancelled. The person that has made these modifications has to apply for a new **CE marking himself**.

Check the Verti-Top Tow Behind for loose bolts, nuts and components *before* every operation.

If present, check the hydraulic pipelines regularly and replace these when the hydraulic pipelines are damaged or appear old. The pipelines that are replaced should comply with the technical requirements of the manufacturer.

If a hydraulic installation is present, you should **always** make it pressure-free *before* working on this installation.

**NEVER** use the Verti-Top Tow Behind in the absence of the safety stickers.

**NEVER** crawl under the Verti-Top Tow Behind.  
If necessary, tilt the Verti-Top Tow Behind.

**NEVER** step off the towing vehicle while the motor is running.

In case of maintenance, adjusting and repairs, it is necessary to block the Verti-Top Tow Behind In order to prevent sinking away, driving off and/or sliding off.

**Always switch off the towing vehicle's motor and take the vehicle's key out of the ignition** in carrying out maintenance, adjustments and repairs (Figure 2).

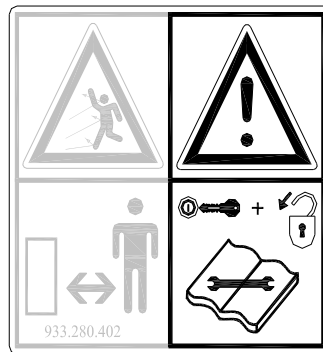

Figure 2

With regards to the safety of the machine and the user, use only original Verti-Top Tow Behind parts for maintenance and repairs.

Only authorised technical personnel may carry out repairs to the Verti-Top Tow Behind.

**Keep a record of the repair activities.**

5. The general applicable health & safety (Dutch: ARBO) regulations must also be followed in addition to the instructions in this user manual.

Relevant traffic regulations also apply in case of using public roads.

**Transporting persons is not permitted!**

Do not use the Verti-Top Tow Behind in the dark, in heavy rain/storm or on slopes with an angle larger than 20 degrees.

6. All persons that are going to operate the Verti-Top Tow Behind must be familiar with all the functions and control elements of the Verti-Top Tow Behind *before* starting any work activities.  
Attach the Verti-Top Tow Behind to the towing vehicle according to the regulations.  
**(Danger of injuries!)**  
Check whether you have a clear field of vision – both close by and far away – *before* you depart.

Safety stickers (Figure 2, 3 and 4) with an identical meaning are attached to both sides (Figure 5) of the Verti-Top Tow Behind. These safety stickers must always be clearly visible and legible and must be replaced if they have become damaged.

During operation, **NO persons are allowed within the danger zone** of the Verti-Top Tow Behind, because there is danger of physical injuries caused by flying material (Figure 3).



Figure 3



Figure 4

**Keep a distance of minimum 4 meters!** Figure 4

Pay attention to the permitted lifting capacity of the towing vehicle.

Dress appropriately. Wear sturdy shoes with steel toecaps, long trousers and tie up long hair. Do not wear loose clothing.

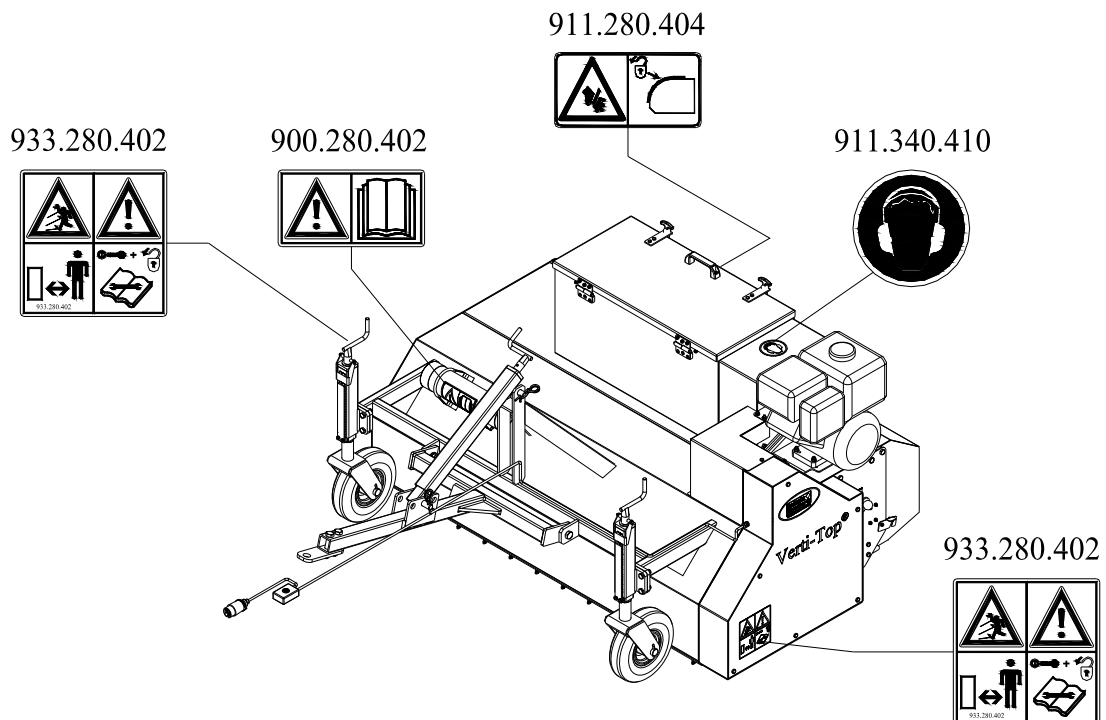

Fig. 5

7. Location of the safety stickers (Figure 5).



## EU DECLARATION

We

**Redexim BV**  
**Utrechtseweg 127**  
**3702 AC Zeist, Holland**

declare entirely under our own responsibility that the product

**VERTI-TOP TOW BEHIND WITH A MACHINE NUMBER AS INDICATED ON THE MACHINE AND INDICATED IN THIS MANUAL**

to which this declaration refers, complies with stipulation of the 2006/42/EC machine directive.

Zeist, 01/10/09

A handwritten signature in blue ink, appearing to be 'A.C. Bos', written over a faint rectangular stamp.

A.C. Bos  
Manager Operations & Logistics  
Redexim Holland

## TABLE OF CONTENTS

<b>EU DECLARATION.....</b>	<b>6</b>
<b>1.0 TECHNICAL DATA .....</b>	<b>8</b>
<b>2.0 GENERAL DESCRIPTION .....</b>	<b>8</b>
<b>3.0 FIRST INSTALLATION – TAKING THE MACHINE OFF THE PALLET .....</b>	<b>9</b>
<b>4.0 ATTACHING TO A VEHICLE.....</b>	<b>10</b>
<b>5.0 ADJUSTING THE WORKING DEPTH.....</b>	<b>11</b>
<b>6.0 ADJUSTING THE ANGLE OF THE JIGGING SIEVE.....</b>	<b>11</b>
<b>7.0 TRANSPORTING THE VERTI-TOP TOW BEHIND .....</b>	<b>12</b>
<b>8.0 DRIVING SPEED DURING WORK .....</b>	<b>12</b>
<b>9.0 USING THE VERTI-TOP TOW BEHIND.....</b>	<b>12</b>
<b>10.0 START/STOP PROCEDURE .....</b>	<b>13</b>
<b>11.0 DETACHING THE VERTI-TOP TOW BEHIND.....</b>	<b>14</b>
<b>12.0 TROUBLE SHOOTING (PROBLEM ANALYSIS).....</b>	<b>15</b>
<b>13.0 MAINTENANCE .....</b>	<b>16</b>
<b>14.0 ADJUSTING THE TENSION OF THE V-BELTS .....</b>	<b>17</b>
<b>15.0 CHANGING THE JIGGING SIEVE .....</b>	<b>18</b>
<b>16.0 OPTIONS OF OTHER JIGGING SIEVES .....</b>	<b>18</b>
<b>17.0 EMPTYING THE DUST BAG.....</b>	<b>19</b>
<b>18.0 ELECTRICAL DIAGRAM FOR THE ELECTRICAL COUPLING.....</b>	<b>20</b>

## 1.0 TECHNICAL DATA

<u>Model</u>	<u>Verti-Top Tow Behind</u>
Working width	1.45m (57")
Working depth (In case of a non-worn brush)	0 mm-26mm (0"-1.02")
Speed	Maximum 12 km/h (7.5 mph)
Weight	320 kg (705.5 lbs)
Towing vehicle	Minimum 18 PK
Maximum capacity (Theoretical at maximum speed of 12 km/h [7.5mph])	17376 m <sup>2</sup> /h (128151 ft <sup>2</sup> /h)
Content per receptacle Total of 2 receptacles per machine	35 litres (1.24 cu. ft.) 70 litres (2.48 cu. ft.)
Mesh width of jiggling sieve	5 mm x 5 mm (0.2" x 0.2")
Transport dimensions	L x W x H 1400mm x 1700mm x 1000mm 55.1" x 66.9" x 39.4"
Attachment	By towing hook
Motor	Briggs and Stratton B&S 6.5 HP
Standard components	<ul style="list-style-type: none"> <li>- Jiggling sieve, adjustable according to cleaning level</li> <li>- Depth adjustment by means of spindles</li> <li>- Removable waste receptacle</li> <li>- Towing hook</li> <li>- Electrical coupling including a switch and 7-pole electrical connection</li> <li>- Container for the manual</li> </ul>
Optional	<ul style="list-style-type: none"> <li>- Sieve elements with various mesh widths</li> </ul>

## 2.0 GENERAL DESCRIPTION

The Verti-Top Tow Behind is a machine for cleaning synthetic grass fields. The machine is also equipped with a vacuum unit for sucking up the particles from the field.



### 3.0 FIRST INSTALLATION – TAKING THE MACHINE OFF THE PALLET

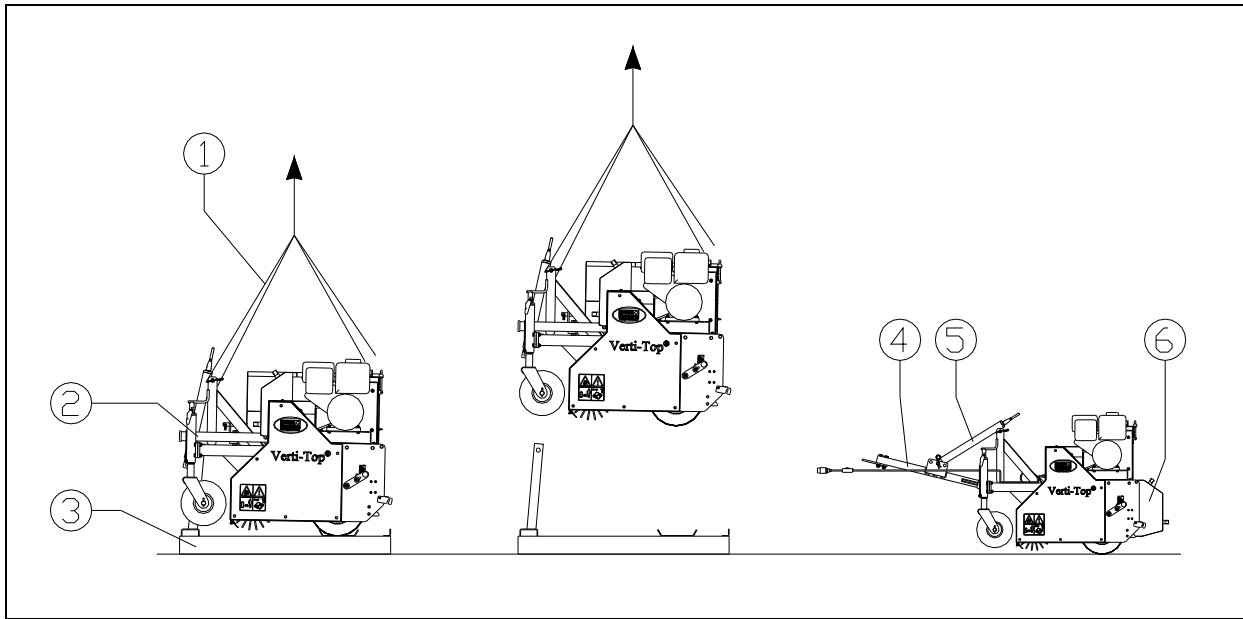

Figure 6

The machine is placed horizontally on the pallet. To remove the pallet and to place the machine horizontally on the ground, you take the following steps (see Figure 6):

**⚠ NEVER crawl under the machine!**

1. Attach a cable (1) to the machine.
2. Remove the bolts and nuts (2) with which the machine is bolted to the pallet (3).

**⚠ Make sure that the cable/crane/lift can hoist minimum 500 kg (1102 lbs).**

3. Lift the machine off the pallet.
4. Pull the pallet from under the machine.
5. Lower the machine controlled and calmly until it stands completely on the ground.

**⚠ Careful: Keep your distance; the machine can slide!**

6. Mount a towing hook (4) on the machine by means of the supplied bolts, nuts and bushes (Figure 6.1).
7. Subsequently, mount the spindle (5) on the towing hook with the supplied pin and locking pin.
8. Place the receptacle (6) at the back of the machine.
9. Connect the machine to the vehicle (please refer to Chapter 4.0).

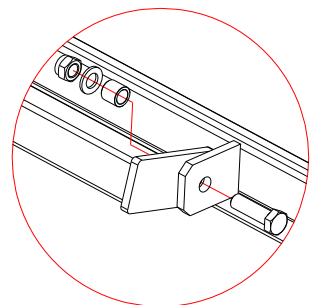

Figure 6.1



**Use the proper vehicle (please refer to the specifications).**



**Switch the vehicle off and make sure the vehicle/Verti-Top Tow behind combination cannot drive away.**

## 4.0 ATTACHING TO A VEHICLE

Checking procedure before starting to attach the Verti-Top Tow Behind.

- Check the Verti-Top Tow Behind for visually discernable damage and repair this if safe operation of the machine is no longer guaranteed.
- Check whether all the nuts and bolts are tight.
- Check whether all safety stickers are present on the machine and are not damaged.

**NEVER** use the machine without these items.

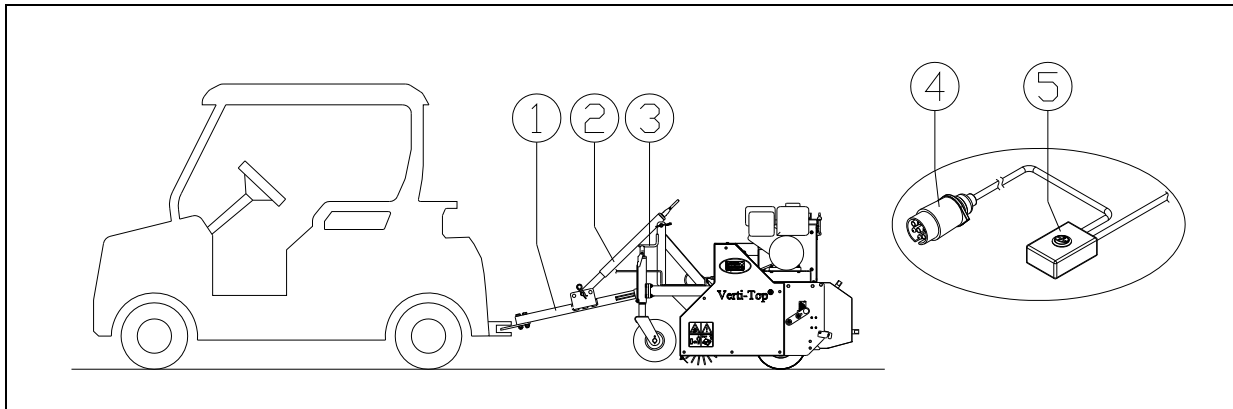

Figure 7

The Verti-Top Tow Behind can be attached to a vehicle by means of a towing hook.

The procedure is as follows (Figure 7):

1. Set the towing hook (1) to the correct height using the spindle so that it can be mounted.
2. Reverse the vehicle carefully so that the towing hook (1) of the machine can be attached to the vehicle.



**Make sure that the towing vehicle is blocked well and cannot move on its own accord!**



**Switch off the vehicle before descending!**

3. Attach the towing hook (1) of the machine to the vehicle and secure it with the securing pin.
4. Turn the spindles (3) completely outwards so that the machine is resting on its front wheels and the brush is free from the ground. Now the machine is tilted backwards.



**Make sure that all the securing pins are locked!**

5. Connect the 7-pole plug (4) to the vehicle.
6. Ensure that the ON/OFF switch (5) for operating the electrical coupling can be operated from the cab.
7. Start the vehicle and begin to drive.

## 5.0 ADJUSTING THE WORKING DEPTH

The working depth of the brush can be adjusted by adjusting the front wheels by turning the spindles (1) at the front side of the machine (See Figure 8).

The start procedure is as follows:

**⚠ Make sure that the Verti-Top Tow Behind is blocked well and cannot move on its own accord!**

**⚠ Switch off the vehicle before descending!**

1. Adjust the spindles (1) by turning them inwards or outwards; this will adjust the working depth.
2. Set both sides of the machine at the same height so that it is possible to clean the field evenly. For this purpose, use the indicator strip (2) and the indication stickers that are in back of it.
3. Secure the spindles by means of the brackets (3) on top of the spindles.

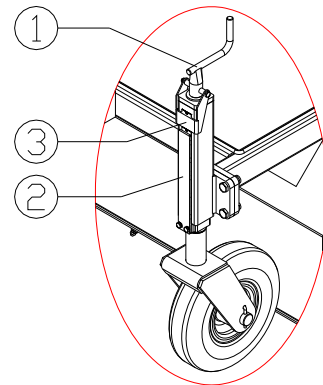

Figure 8

**NEVER adjust the machine** in such a way that it could damage the subsoil.

**⚠ IMPORTANT!**

**First check the working depth on the subsoil statically *before* using the machine!**

- Experience shows that the machine adjustment for top-layer cleaning is best if the brush hairs just don't touch the grass fibres.

## 6.0 ADJUSTING THE ANGLE OF THE JIGGING SIEVE

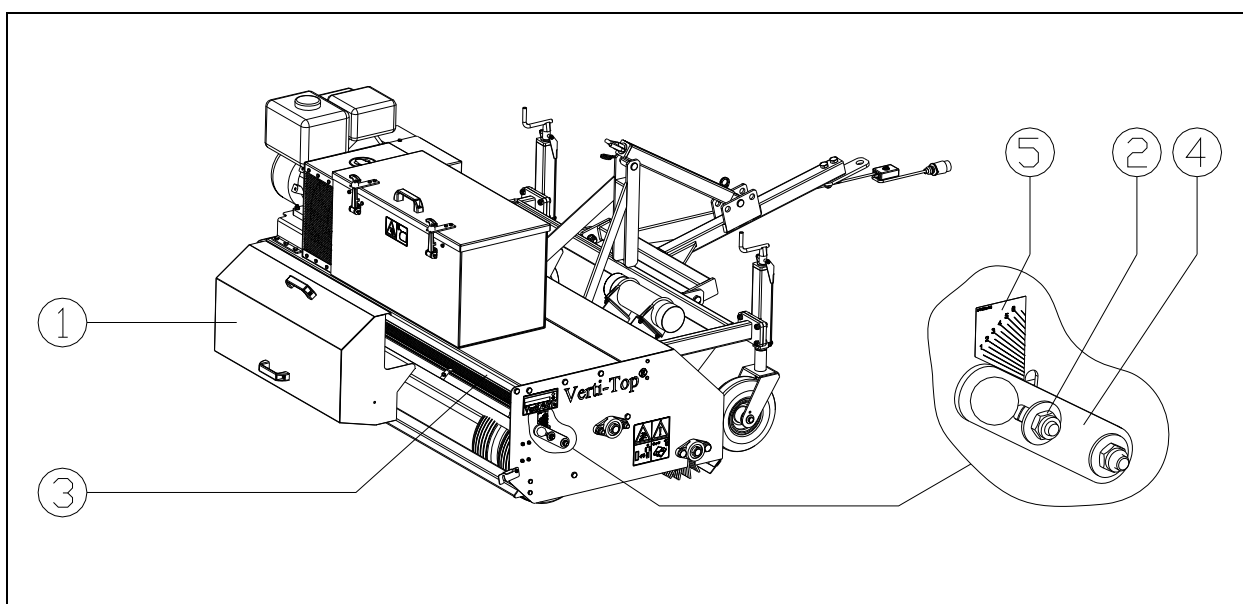

Figure 9

If the receptacle is catching too much material that should have been sieved, it is possible to allow the jiggling sieve more time for sieving the material.

This is done by placing the jiggling sieve under an angle.  
The procedure is as follows (see Figure 9):

 **Make sure that the vehicle and the Verti-Top Tow Behind is blocked well and cannot move on its own accord!**

 **Switch off the vehicle before descending!**

1. Remove the receptacles (1) at the back of the machine.
2. Loosen the nuts (2) one turn on both sides of the machine.
3. Using the handles (4) on both sides, adjust the jiggling sieve (3) so that it is parallel and at the required angle. For this purpose, make use of the indication stickers (5).
4. Tighten the nuts (2) on both sides of the machine.
5. Return the receptacles (1) to the back of the machine.

 **BE CAREFUL not to get any parts of your body jammed!**

## 7.0 TRANSPORTING THE VERTI-TOP TOW BEHIND

The user is responsible for transporting the Verti-Top Tow Behind in back of the vehicle over public roads. Verify the national legislation regarding the regulations.  
On open fields while the machine is raised and if circumstances allow this, the maximum permitted speed is 20 km/h (12.4 mph) due to the weight of the Verti-Top Tow Behind. A higher speed can be dangerous for the driver and/or the public and can even damage the machine.

## 8.0 DRIVING SPEED DURING WORK

The driving speed is limited to 12 km/h (7.5mph).  
It is NOT recommended to drive faster due to the fact that excessive wear & tear and damage can occur to the machine and to the subsoil.

## 9.0 USING THE VERTI-TOP TOW BEHIND

Before using the Verti-Top Tow Behind in a location, you should check the following items:

1. Are there loose objects in the field? First remove these objects.
2. Are there slopes? The maximum slope is 20 degrees for this machine. Always go from top to bottom.
3. Is there danger of flying objects (e.g., balls) that distract the attention of the driver? If so, the Verti-Top Tow Behind **CANNOT** be used.
4. Is there danger of sinking/sliding away? If so, postpone the processing until conditions improve.
5. If the soil is wet, postpone the work activities until conditions improve.
6. A field can be worked several times in the same or different directions in order to obtain better cleaning.
7. Do not make sharp bends and preferably, drive in straight lines; otherwise you might damage the subsoil.

## 10.0 START/STOP PROCEDURE

The start procedure is **VERY** important. If this procedure is not executed as described below, serious damage to the machine / subsoil could be the result.

The start procedure is as follows:

1. Check the Verti-Top Tow Behind for loose components and look whether all components function properly.

**⚠ If loose components are observed or components do not function properly, the problems must be solved *before* using the Verti-Top Tow Behind!**

2. Drive to the spot where the processing should take place.
3. Set the working depth of the machine statically as described in Chapter 5.0.

**⚠ Make sure that the towing vehicle is blocked well and cannot move on its own accord!**

**⚠ Switch off the vehicle before descending!**

**⚠ Make sure that the ON/OFF switch for operating the electrical coupling is OFF!**

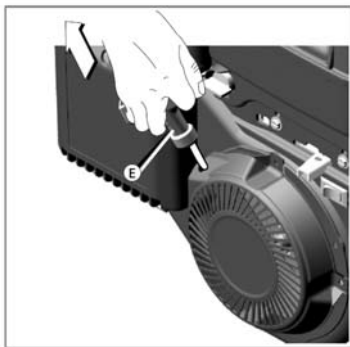

Figure 10



Figure 11

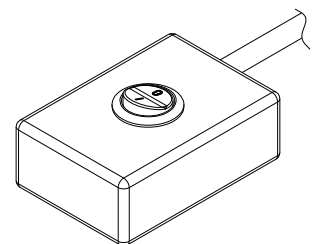

Figure 12

4. Start the motor of the Verti-Top Tow Behind (Figure 10).
5. Set the slide switch of the motor (Figure 11) in the highest position.
6. Ascend the vehicle, start moving it forward and switch the electrical coupling ON by means of the switch (Figure 12).
7. Increase the driving speed to maximum 12 km/h (7.5 mph).

Stopping occurs as follows:

1. While driving, switch OFF the electrical coupling (Figure 12).
2. Stop the vehicle.

**⚠ Make sure that the towing vehicle is blocked well and cannot move on its own accord!**

**⚠ Switch off the vehicle before descending!**

3. Set the slide switch of the motor (Figure 11) in the lowest position.
4. Switch OFF the motor.
5. Lift the machine, drive to the next location and start the operation as described above.

## 11.0 DETACHING THE VERTI-TOP TOW BEHIND

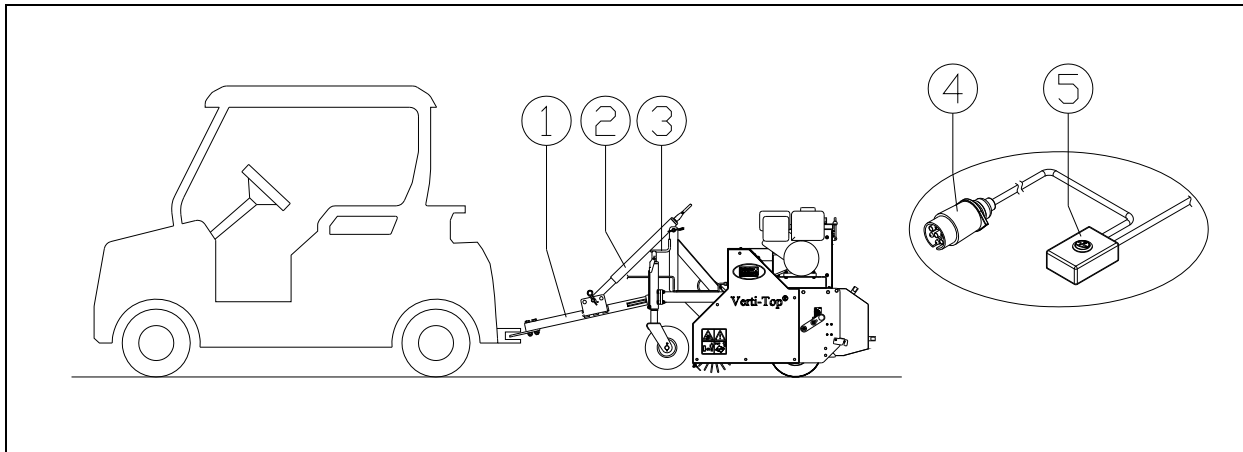

Figure 13

The machine can be detached from the towing vehicle in the following manner (See Figure 13):

1. Drive the Verti-Top Tow Behind to a parking area with a firm/flat surface.



**Make sure that the pulling vehicle is blocked well and cannot move on its own accord!**



**Switch off the vehicle before descending!**

2. Disconnect the 7-pole plug (4) and pull back the ON/OFF switch (5) of the electrical coupling.
3. If necessary, slacken the towing hook by means of the spindle (2).
4. Detach the towing hook of the Verti-Top Tow Behind from the vehicle.
5. Turn the spindles (3) completely outwards so that the brush is not touching the ground.



**Make sure that the Verti-Top Tow Behind stands stable and cannot roll away and/or slide off!**

6. Start the vehicle and begin to drive.

- **When putting away the machine, it is advised not to have the brush touch the ground or any other objects in order to prevent the risk of bending the brush hairs.**

## 12.0 TROUBLE SHOOTING (PROBLEM ANALYSIS)

<b>Problem</b>	<b>Possible cause</b>	<b>Solution</b>
The waste receptacle has collected too much material that needs to be cleaned	Jigging sieve is adjusted too flat	Adjust the jigging sieve more under an angle (see Ch. 7.0) (see Ch. 6.0)
	Working depth is adjusted too deep	Adjust the machine to less depth
	Jigging sieve is clogged	Open up the jigging sieve or apply a larger sieve.
	Driving speed is too low	Increase the driving speed
	Surroundings are too wet	Wait till surroundings are dried up. Use a sieve with a larger mesh.
Too little cleaning	Working depth is adjusted too shallow	Adjust the machine to more depth
	Driving speed is too high	Lower the driving speed
	Sieve with too large a mesh	Replace sieve with a smaller meshed sieve
	Brush is worn out	Replace brush
	Outlet opening of the brush is blocked	Remove blockage
	V-belts are slipping	Tighten the V-belts (see Ch. 14)
	Dust bag is full.	Empty the dust bag.
	Dust bag is dirty.	Rinse or blow the dust bag clean.
Sloppy image of the field after processing	Machine is adjusted too deep	Adjust the machine to less depth
Squeaking noises during the machine's operation	Bearings need greasing or are worn out.	Grease the bearings with EP2 grease or replace them.

## 13.0 MAINTENANCE

Time schedule	Check/Grease point	Method
Before <b>every</b> use	<p>Check for loose bolts/nuts</p> <p>Presence and readability of the safety stickers (Please refer to Figure 5)</p>	<p>Tighten loose bolts/nuts with the correct tightening moment</p> <p>Replace these if not present or damaged</p>
After the <b>first</b> 20 working hours (new or repaired)	<p>Grease the bearings of the brush and the driveline.</p> <p>Check for loose bolts/nuts</p> <p>Check the tension of the V-belts</p>	<p>Use EP2 grease</p> <p>Tighten loose bolts/nuts with the correct tightening moment</p> <p>If necessary, adjust the tension of the V-belts (see Ch. 14)</p>
After <b>every</b> 100 working hours or annually	<p>Grease the bearings of the brush and the driveline.</p> <p>Check for loose bolts/nuts</p> <p>Check the tension of the V-belts / wear &amp; tear</p> <p>Check the wear of the brushes</p>	<p>Use EP2 grease</p> <p>Tighten loose bolts/nuts with the correct tightening moment</p> <p>Adjust the tension of the V-belts (see Ch. 14) or – if required – replace the V-belts</p> <p><b>Rotating brush:</b> If necessary, replace the brush</p>



## 14.0 ADJUSTING THE TENSION OF THE V-BELTS

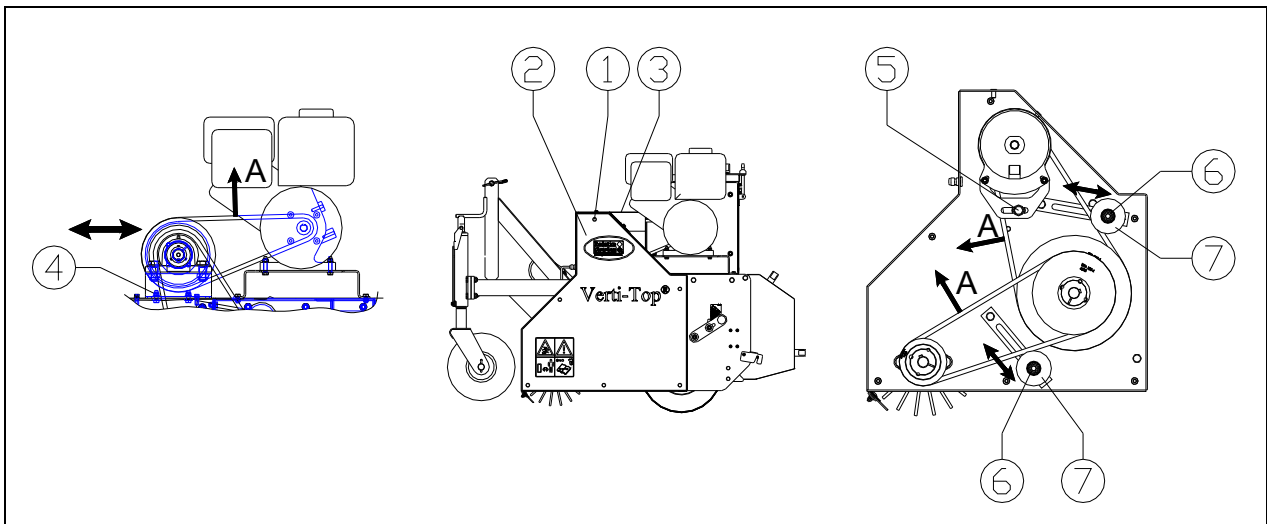

Figure 14

The Verti-Top Tow Behind is standard equipped with adjustable tension pulleys that keep the V-belts taut.

Depending on the intensity of using the machine, wear and tear can occur to the driveline resulting in slipping of the V-belts.

These V-belts should then be tightened.

Adjusting the bracket and the tension pulleys is done as follows (see Figure 14):

- ⚠ **Make sure that the Verti-Top Tow Behind is blocked well and cannot move on its own accord!**
- ⚠ **Ensure that the motor of the Vert-Top Tow Behind is OFF!**

1. Remove all nuts (1) and the safety cap (2) at the side of the machine.
2. Remove the protective cap (3) at the motor side.

First you have to check the V-belts at the motor side and – if necessary – pull them taut *before* you can proceed with pulling the V-belts taut at the side.

3. Loosen the nuts (4) of the bracket and the bolt (5) of the coupling support.
4. Tighten the bracket by moving it. **PAY ATTENTION** that it remains well aligned and NOT tilted.
5. Tighten the nuts (4) of the bracket and the bolt (5) of the coupling support.
6. Check the tension of the V-belt by pulling on point A with a tension of 4.5 kg (9.9lbs). The stretch should be 2 mm (0.08”).
7. If required, pull the bracket taut again until the correct tension is achieved.

Subsequently, proceed with pulling the V-belts taut at the side; do the following:

8. Loosen the nut (6).
9. Tighten the tension pulley by moving it.
10. Tighten the nut (6).
11. Check the tension of the V-belt by pulling on point A with a tension of 4.5 kg (9.9lbs). The stretch should be 2 mm (0.08”).
12. If required, pull the tension pulley taut again until the correct tension is achieved.
13. If the tension of the V-belts is OK, return the protective caps (2 & 3) and tighten all the nuts (1) and bolts.

## 15.0 CHANGING THE JIGGING SIEVE

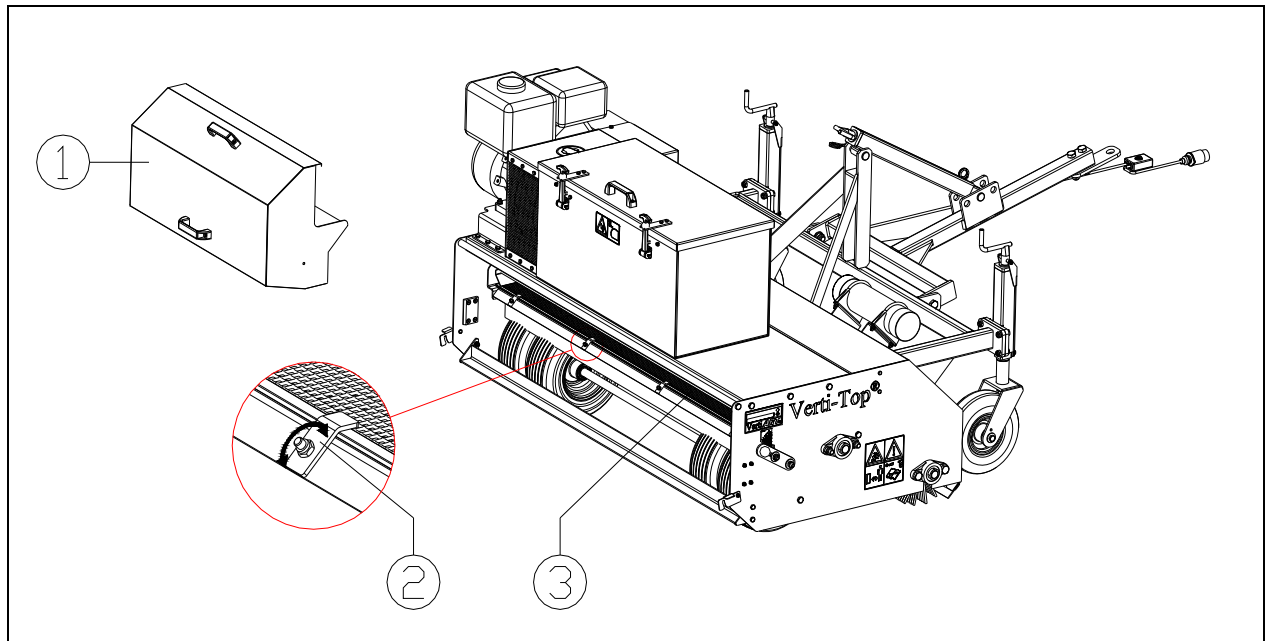

Figure 15

Verti-Top Tow Behind comes with seven different interchangeable meshes for processing the different types of materials.

Changing the jiggling sieve is done as follows (see Figure 15):

**⚠ Make sure that the Verti-Top Tow Behind is blocked well and cannot move on its own accord!**

1. Remove the receptacles (1) at the rear of the Verti-Top Tow Behind.
2. Turn the clips (2) a quarter of a turn so that the sieve becomes undone.
3. Remove the sieve (3) and replace this one with another sieve.
4. Turn the clips (2) back so that the sieve is blocked.
5. Return the receptacles (1) to the rear of the Verti-Top Tow Behind.

**⚠ BE CAREFUL not to get any parts of your body jammed!**

## 16.0 OPTIONS OF OTHER JIGGING SIEVES

It is possible to mount another sieve with a larger or smaller mesh if a different type of material has to be sieved or the material has other dimensions for which the standard mounted jiggling sieve is inadequate.

The following sieves are available for the Verti-Top:

Mesh (mm)	Mesh (inch)	Spare part number
3.2x3.2	0.13x0.13	458.441.431
4x4	0.16x0.16	458.441.432
5x5	0.2x0.2	458.441.430 (Standard)
5.5x5.5	0.21x0.21	458.441.433
6x6	0.24x0.24	458.441.434

## 17.0 EMPTYING THE DUST BAG

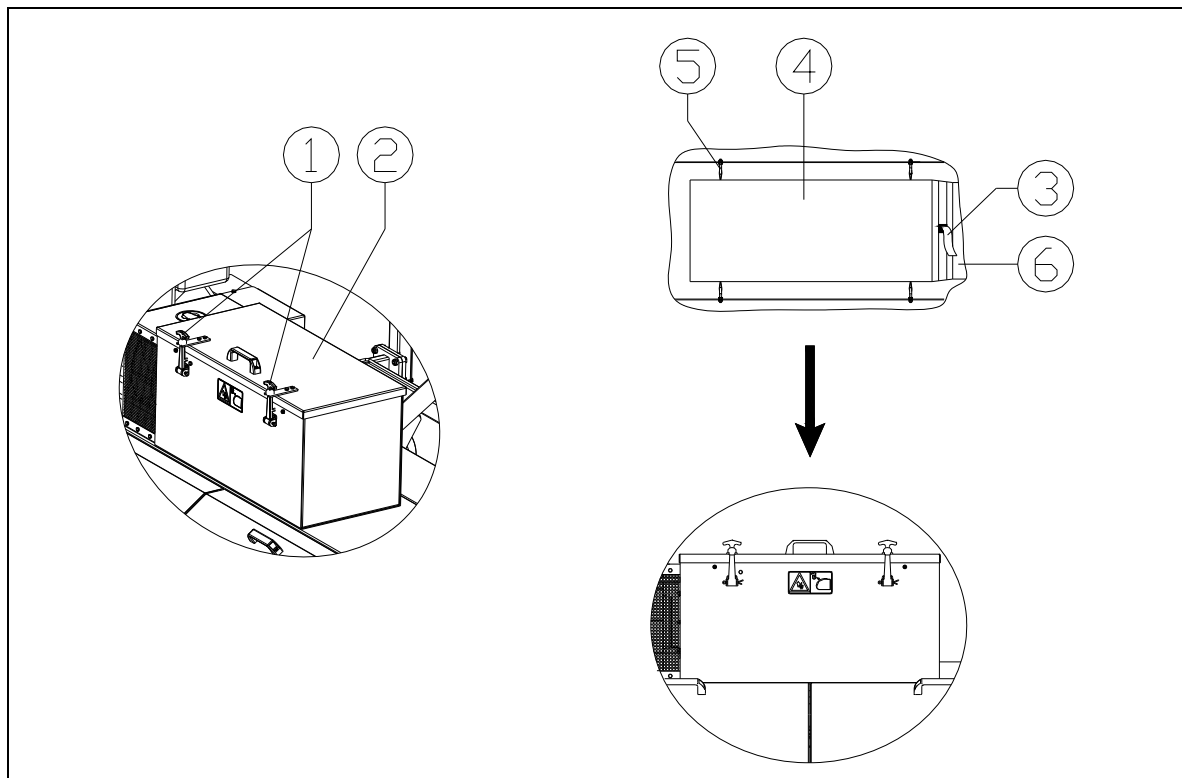

Figure 16

Emptying the dust bag is done as follows (See Figure 16)

- ⚠ **Make sure that the vehicle and the Verti-Top Tow Behind is blocked well and cannot move on its own accord!**
- ⚠ **Switch off the vehicle before descending!**
- ⚠ **Make sure that the motor of the Verti-Top Tow Behind can no longer operate when changing the dust bag!**
- ⚠ **Wear the proper personal protection gear when changing the dust bag!**

1. Open the cover closures (1).
2. Open the cover (2) of the vacuum unit.
3. Loosen the taut band (3).
4. Remove the dust bag (4) from the hooks (5) and take it out.
5. Empty the dust bag (4).
6. Hang the dust bag (4) on the hooks (5) and fixed to the suction mouth (6).
7. Tighten the taut band (3).

⚠ **BE CAREFUL not to get any parts of your body jammed!**

8. Close the cover (2) of the vacuum unit and secure it with the cover closures (1).



**Remove waste according to the applicable stipulations of the local legislation.**

# 18.0 ELECTRICAL DIAGRAM FOR THE ELECTRICAL COUPLING

An electrical coupling on the machine is used for switching ON the brush of the Verti-Top Tow Behind. The following figure represents the connectivity of the electrical coupling and the switch.

