

TURF-STRIPPER 1600

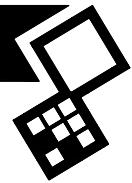

Translation of the original user manual





2212 English 953.200.002 EN

FOREWORD

Congratulations on your Turf-Stripper purchase! For safe and long-lasting operation of this Turf-Stripper, it is necessary to read and to understand this user manual. It is impossible to work safely with this machine *without* complete knowledge of its content.

The Turf-Stripper is not a machine that works independently. It is the user's responsibility to use the correct tractor. The user must also check the tractor/Turf-Stripper combination on safety aspects such as noise level, user instructions and risk analysis.

The following pages deal initially with the general safety instructions. Every user should know these safety instructions and apply them. At the end of this page, a registration card is inserted. This registration card should be returned to enable us to deal with potential future claims.

This user manual lists many instructions that are numbered in sequence. You should follow this sequence. A  is an indication of a safety instruction. A  means a tip and/or note.

All information and technical specifications provided at the moment that this document is published are the most recent ones. Design specifications may be changed without prior notice.

This document is a translation of the original operating instructions. Upon request, the original operating instructions are available in Dutch.

WARRANTY CONDITIONS

WITH DELIVERY THIS TURF-STRIPPER IS GUARANTEED AGAINST MATERIAL DEFECTS. THIS WARRANTY IS VALID FOR A PERIOD OF 12 MONTHS FROM THE PURCHASE DATE. TURF-STRIPPER WARRANTIES ARE SUBJECT TO THE 'GENERAL CONDITIONS FOR SUPPLY OF PLANT AND MACHINERY FOR EXPORT, NUMBER 188' THAT ARE PUBLISHED UNDER THE AUSPICES OF THE UNITED NATIONS ECONOMIC COMMISSION FOR EUROPE.

REGISTRATION CARD

For your own information, fill in the table below:

Serial number of the machine	
Dealer name	
Date of purchase	
Remarks	

SAFETY INSTRUCTIONS

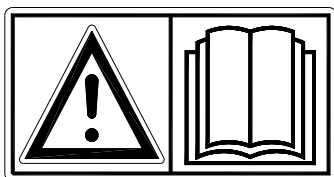

Figure 1

The Turf-Stripper is designed for safe use. This can only be achieved if you completely follow the safety instructions described in this manual.

Read and understand (Figure 1) the manual *before* you start using the Turf-Stripper.

If the machine is not used as described in this manual, this can result in injuries and/or damage to the Turf-Stripper.

1. The user must be an expert in using the machine. The machine should be professionally adjusted for cultivating the subsoil.

The manufacturer will not accept any liability for unprofessional use and its resulting damage. All risks occurring with this are entirely at the expense of the user. Following the use, maintenance and repair instructions prescribed by the manufacturer is also considered professional use of this machine.

Inspect the area to be treated *before* using the Turf-Stripper.
Remove loose obstacles and avoid irregularities.

2. The Turf-Stripper is manufactured according to the latest technical understanding and is safe to use.

When unskilled people use, maintain or repair the machine, this could result in injuries to the user *and* to third parties. **This must be avoided!**

Always use the Turf-Stripper in combination with the correct tractor as described in the technical data.

3. All persons assigned to operate, maintain and repair the Turf-Stripper by the owner must completely read and understand the operation manual and in particular the chapter of **Safety Instructions**.

The user is responsible for a **safe Tractor/Turf-Stripper combination**. **This entire combination must be tested** for noise, safety, risk and user friendliness. User instructions should also be drafted.

4. The user is obliged to check the Turf-Stripper for **visible damage and defects** before using the Turf-Stripper.
Modifications to the Turf-Stripper (including its operations) that have a negative impact on safety must be rectified immediately.
For safety reasons it is in principle not permitted to make changes or adjustments to the Turf-Stripper (except those approved by the manufacturer).

If **modifications** to the Turf-Stripper have been made, then the current CE marking is cancelled. The person that has made these modifications has to apply for a new **CE marking himself**.

Check the Turf-Stripper for loose bolts, nuts and components *before* every operation.

If present, check the hydraulic pipelines regularly and replace these when the hydraulic pipelines are damaged or appear old. The pipelines that are replaced should comply with the technical requirements of the manufacturer.

If a hydraulic installation is present, you should **always** make it pressure-free *before* working on this installation.

NEVER use the Turf-Stripper in the absence of the safety stickers.

NEVER crawl under the Turf-Stripper.
If necessary, tilt the Turf-Stripper.

NEVER step off the tractor while the motor is running.

In case of maintenance, adjusting and repairs, it is necessary to block the Turf-Stripper in order to prevent sinking away, driving off and/or sliding off.

Always switch off the tractor motor, take the tractor's key out of the ignition and disconnect the PTO in case of maintenance, adjusting and repairs (Figure 2).



Figure 2

With regards to the safety of the machine and the user, use only original Turf-Stripper parts for maintenance and repairs.

Only authorised technical personnel may carry out repairs to the Turf-Stripper.

Keep a record of the repair activities.

5. The general applicable health & safety (Dutch: ARBO) regulations must also be followed in addition to the instructions in this user manual.

Relevant traffic regulations also apply in case of using public roads.

Transporting persons is not permitted!

Do not use the Turf-Stripper in the dark, in heavy rain/storm or on slopes with an angle larger than 20 degrees.

6. All persons that are going to operate the Turf-Stripper must be familiar with all the functions and control elements of the Turf-Stripper *before* starting any work activities.

Attach the Turf-Stripper to the towing vehicle according to the regulations.

(Danger of injuries!)

Check whether you have a clear field of vision – both close by and far away – *before* you depart.

Safety stickers with an identical meaning are attached to the rear cover (Figure 5 and 6) and to both sides (Figure 2, 3 and 4) of the Turf-Stripper. These safety stickers must always be clearly visible and legible and must be replaced if they have become damaged.

During operation, **NO persons without the proper protection gear are allowed within the danger zone** of the Turf-Stripper, because there is danger of physical injuries caused by flying particles or substances (Figure 3).



Figure 3



Figure 4

Keep a distance of minimum 4 metres! (Figure 4)

The rear cover must always be closed and undamaged while operating the machine! (Figure 5)

BE CAREFUL not to get any parts of your body jammed! (Figure 6)

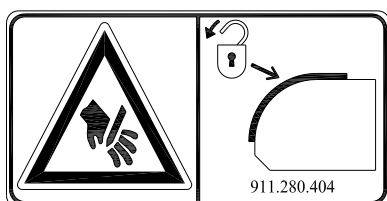

Figure 5



Figure 6

Pay attention to the permitted lifting capacity of the towing vehicle.

Dress appropriately. Wear sturdy shoes with steel toecaps, long trousers and tie up long hair. Do not wear loose clothing.

Use the proper personal protection gear according to the applicable health & safety (Dutch acronym: ARBO) and safety regulations.

7. Location of the safety stickers (Figure 7)

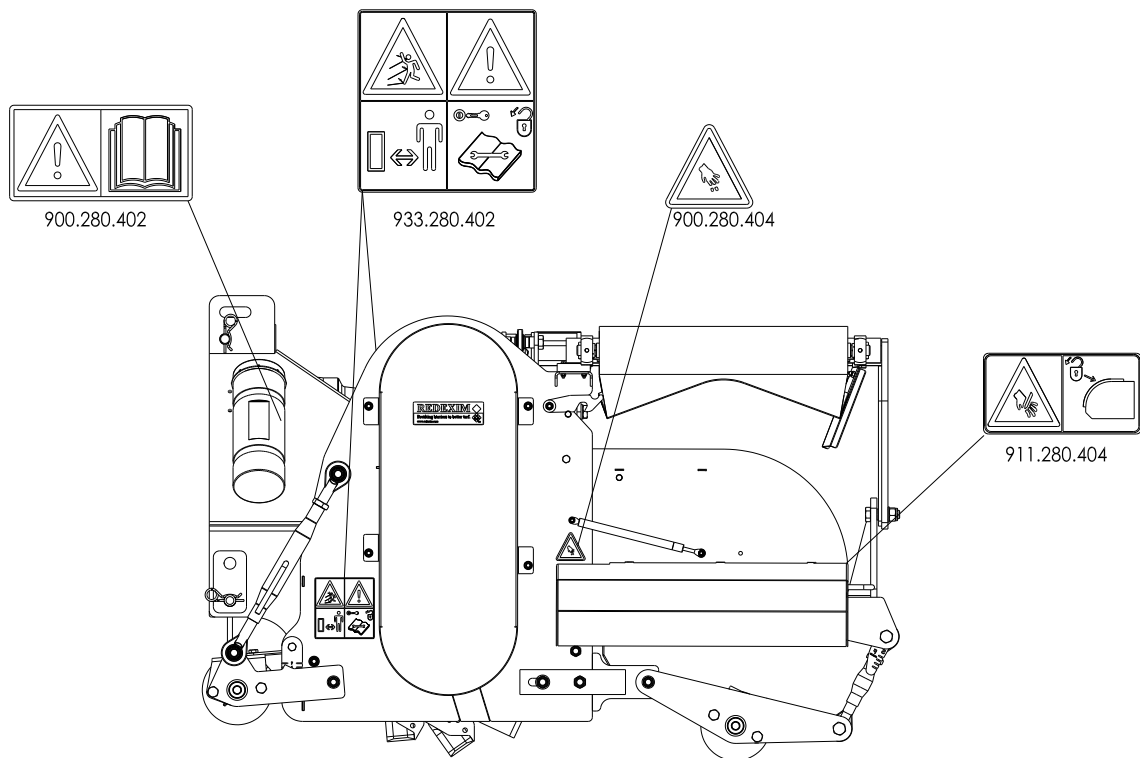

153PR001-MN01

Fig. 7

Used oil/grease is harmful to the environment. Dispose of these substances according to the regulations that apply in your location.

EU DECLARATION



We – **Redexim BV, Utrechtseweg 127, 3702 AC Zeist, Holland** – declare entirely under our own responsibility that the product

TURF-STRIPPER WITH A MACHINE NUMBER AS INDICATED ON THE MACHINE AND INDICATED IN THIS MANUAL

to which this declaration refers, complies with stipulation of the 2006/42/EC machine directive and is in conformity with the following standards: NEN-EN-ISO 12100 : 2010 NEN-EN-ISO 13857 : 2008

Zeist, 12.01.2018

A handwritten signature in blue ink, appearing to be 'A.C. Bos', written over a light blue grid background.

A.C. Bos
Manager Operations & Logistics
Redexim Holland

TABLE OF CONTENTS

WARRANTY CONDITIONS	2
REGISTRATION CARD	2
SAFETY INSTRUCTIONS	3
EU DECLARATION.....	7
1. TECHNICAL DATA	9
2. GENERAL DESCRIPTION	9
3. FIRST INSTALLATION – TAKING THE MACHINE OFF THE PALLET...	10
4. ATTACHING THE MACHINE TO THE TRACTOR	11
5. THE POWER TAKE-OFF (PTO).....	12
5.1 LENGTH OF THE PTO	12
5.2 USING THE PTO.....	13
6. ASSEMBLING THE FRASE BLADES.....	13
7. ADJUSTING THE WORKING DEPTH	14
8. TRANSPORTING THE TURF-STRIPPER	15
9. DRIVING SPEED	15
10. USING THE TURF-STRIPPER.....	15
11. START/STOP PROCEDURE	16
12. DETACHING THE TURF-STRIPPER.....	17
13. TROUBLE SHOOTING (PROBLEM ANALYSIS).....	18
14. MAINTENANCE	19
14.1 LUBRICATING POINTS	20
14.2 ADJUSTING THE TENSION OF THE V-BELTS	21
14.3 CONVEYOR BELT ALIGNEMENT	22
15. OPTIONAL: SCARIFY KNIVES (ROTOR 488.355.185)	23

1. TECHNICAL DATA

	<u>1600</u>
Working width	1.6m (63")
Working depth	Up to 50mm (2")
Working speed	The working speed depends on the conditions and the required result. It is maximum 3 km/h (1.8 mph).
Discharge height	1,5m (59")
Weight in kg	1160 Kg (2552 lbs)
Three-point connection	Cat. 2
Gearbox oil to be used	SAE 140
Bearing grease to be used	EP2
Recommended tractor	35 - 50 HP
Minimum lift capacity of the tractor 610mm (24") behind the link arms	1450 kg (3640lbs)
Hydraulic connections of the tractor	2x double-acting valves
PTO revs	540 rpm
Standard items	PTO Fraser knives
Optional	Scarify knives

2. GENERAL DESCRIPTION

The Turf-Stripper is a processing machine for a fraser operation or scarifying and transporting the removed material.

3. FIRST INSTALLATION – TAKING THE MACHINE OFF THE PALLET

The machine is placed vertically on the pallet. To remove the pallet and to place the machine horizontally on the ground, take the following steps (see Figure 8):

- ⚠ **NEVER crawl under the machine!**
- 1. Attach a cable to the lifting eyes on both sides of the machine.
- ⚠ **Make sure that the cable/crane/lift can hoist minimum twice the weight of the machine. (See Chapter 1.0 ‘Technical Data’ for the weight details.)**
- 2. Lift the machine including the pallet of approx. 50 mm (2”) off the ground.
- 3. Remove the pallet by removing the three-point pins.
- ⚠ **NEVER crawl under the machine!**
- 4. Slowly lower the machine until it touches the ground.
- 5. Rotate the machine so that it is positioned straight on the ground.
- ⚠ **Attention: the machine can swing dangerously!**
- 6. ⚠ **Remove transport bracket 1**
- 7. Attach the machine to a tractor. (See Chapter 4.0 for instructions about attaching to the tractor.)
- ⚠ **Use the proper tractor (please refer to the specifications).**
- ⚠ **Turn off the tractor and secure the tractor/Turf-Stripper combination against driving off and/or sliding off.**

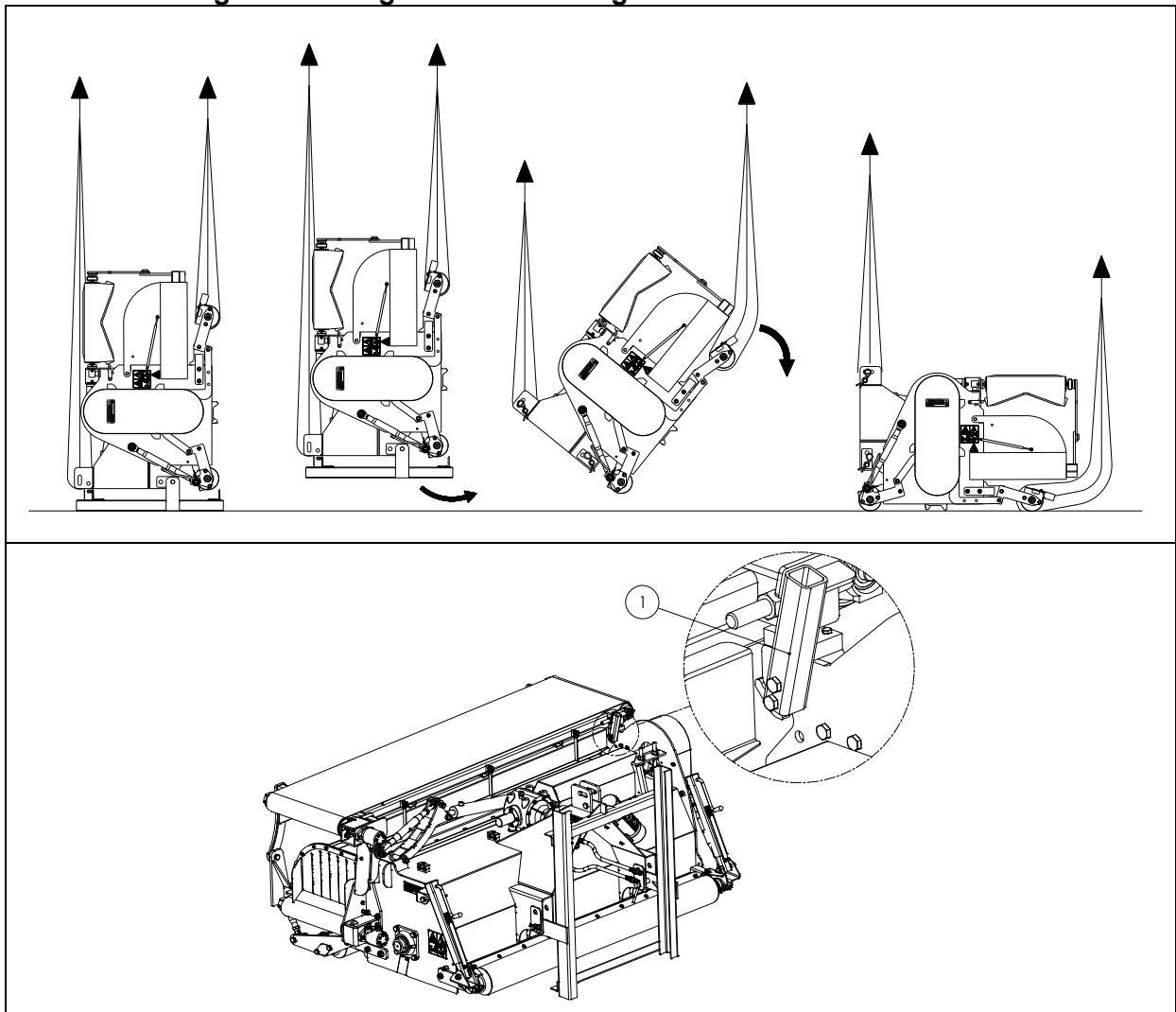

TS 2000 Fig. 8

4. ATTACHING THE MACHINE TO THE TRACTOR

Checking procedure before starting to attach the Turf-Stripper.

- Check the Turf-Stripper for visually discernable damage and repair this if safe operation of the machine is no longer guaranteed.
- Check whether all the nuts and bolts are tight.
- Check whether all safety stickers are present on the machine and are not damaged.

NEVER use the machine without these items.

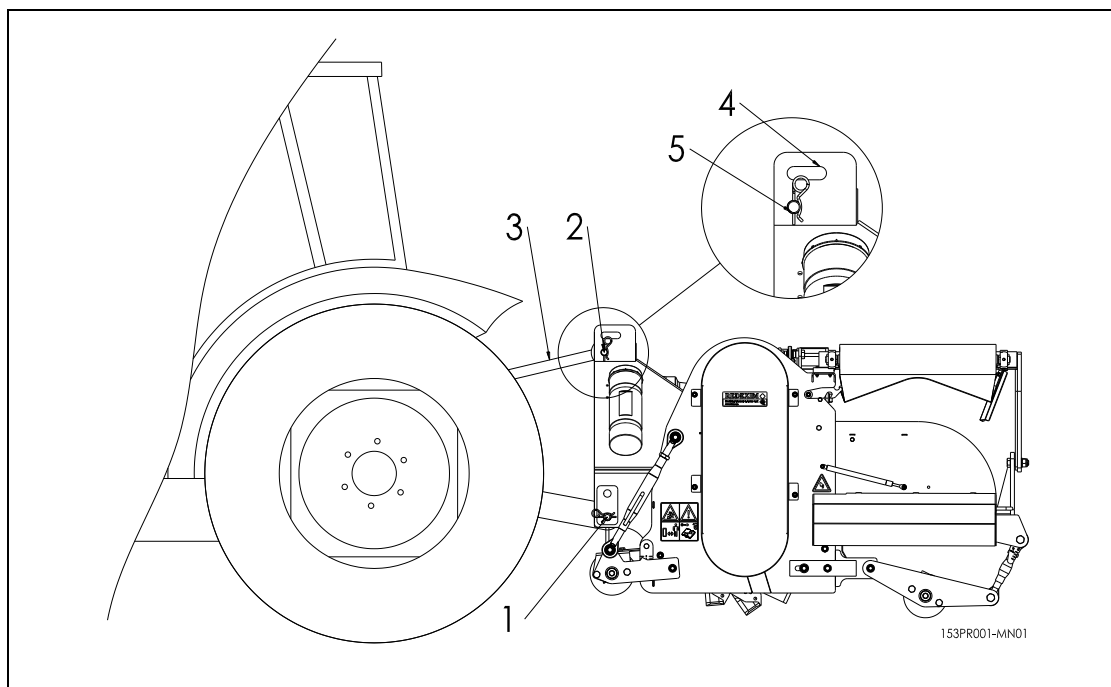

Figure 9

The Turf-Stripper can be attached to the tractor by means of the 3-point attachment.

The procedure is as follows (Figure 9):

1. Remove the 3-point pins (1 and 2).
2. Drive the tractor carefully backwards so that the lower connecting arms can be attached to the frame.
 - ⚠ **Make sure that the tractor is blocked well and cannot move on its own accord!**
 - ⚠ **Switch off the tractor before descending!**
3. Connect the lower connecting arms to the 3-point connecting plates using the pins (1) and secure these with the supplied locking pins.
4. Set the stabilizer of the tractor to 100 mm lateral stroke.
5. Connect the top rod (3) to the frame with the pin (2); secure the pin (2) with the supplied locking pin.
 - ⚠ **Use Float Position 4 for towing while operating the Turf-Stripper and Fixed Position 5 for transport!**
 - ⚠ **Make sure that all the securing pins are locked!**
6. Turn the top rod (3) until the Turf-Stripper stands horizontally on the ground.
7. Attach the PTO to the Turf-Stripper.
8. Attach the hydraulic hoses of the Turf-Stripper to the tractor.
9. Start the tractor and lift the Turf-Stripper off the subsoil.

5. THE POWER TAKE-OFF (PTO)

The PTO is a very important component. It also takes care of safe use of the machine, provided it is installed and maintained in the correct manner. The PTO has its own CE certification. Read the PTO manual. This manual is located on the PTO.

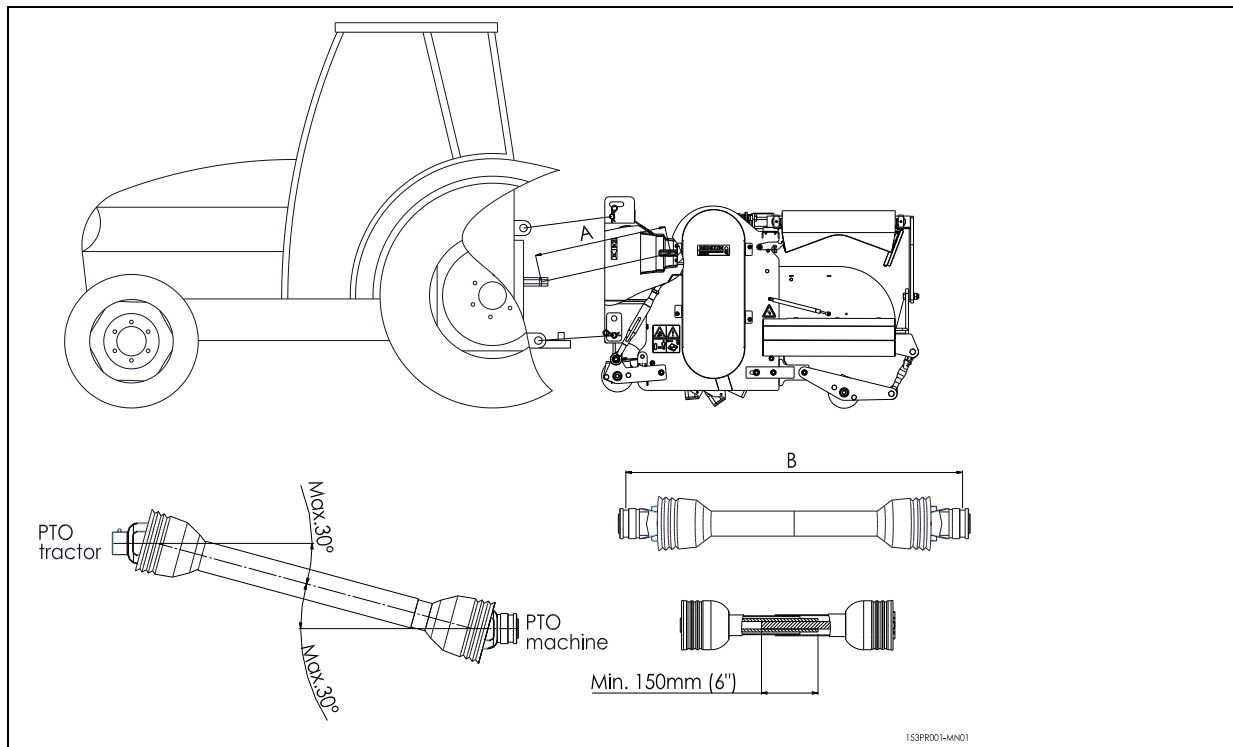

5.1 LENGTH OF THE PTO

The length of the PTO is very important. If it is too long, it can damage the drive of the tractor and/or the Turf-Stripper. If the overlapping length of the cylinders becomes less than 150 mm (6") at any time, it can damage the PTO.



The length changes when the machine is lifted or when a different tractor is used!

In order to set the PTO to the correct length, when a new one has been purchased or when a different tractor is used, follow these steps (see Figure 9):

1. Measure the distance A between the PTO's connection to the tractor and to the Turf-Stripper, from groove to groove, when the machine is connected to the tractor and positioned on the ground at the right angle.
2. Measure the distance B of the PTO in its shortest position from the locking pin to pin.
3. Divide the PTO in two parts and remove the protection cap at both ends.
4. The ends of the cylinders and the ends of the protection caps must be made shorter: $(B - A) + 75 \text{ mm (3")}$.
5. Smooth off all components, use some grease, and then assemble all components.
6. Attach the PTO to the Turf-Stripper.



The torque of the locking bolt must be 80 Nm (700 lb.in.) and should be checked every 40 hours.

7. Attach the other end of the PTO to the tractor.
8. Check the overlap of the cylinders.



Never use the machine if it has a damaged PTO protection cap. First replace any damaged parts!

5.2 USING THE PTO

The following items must be checked for correct use of the PTO:

1. While working the angle of the PTO may not exceed 30 degrees.
2. The PTO must always be aligned between the tractor and machine.
3. The overlap of the cylinders must always be minimum 150 mm.
4. Never use the machine if it has a damaged PTO protection cap.
5. For lubrication, please refer to Chapter 14.0 'Maintenance'.

6. ASSEMBLING THE FRASE BLADES

For the assembly of the frase blades it is necessary to point the frase blades facing to the left or the right to obtain a correct overlap.

To clarify the correct position in some of the rotor plates a "Notch" is cut. This means then that the frase blade must be facing to the left-hand side of the machine. If there is no "Notch" present on the plate, the frase blade must be facing to the right-hand side of the machine.



Important! Always let the knife edge rest against the rotor plate!

(See Fig. 10a)

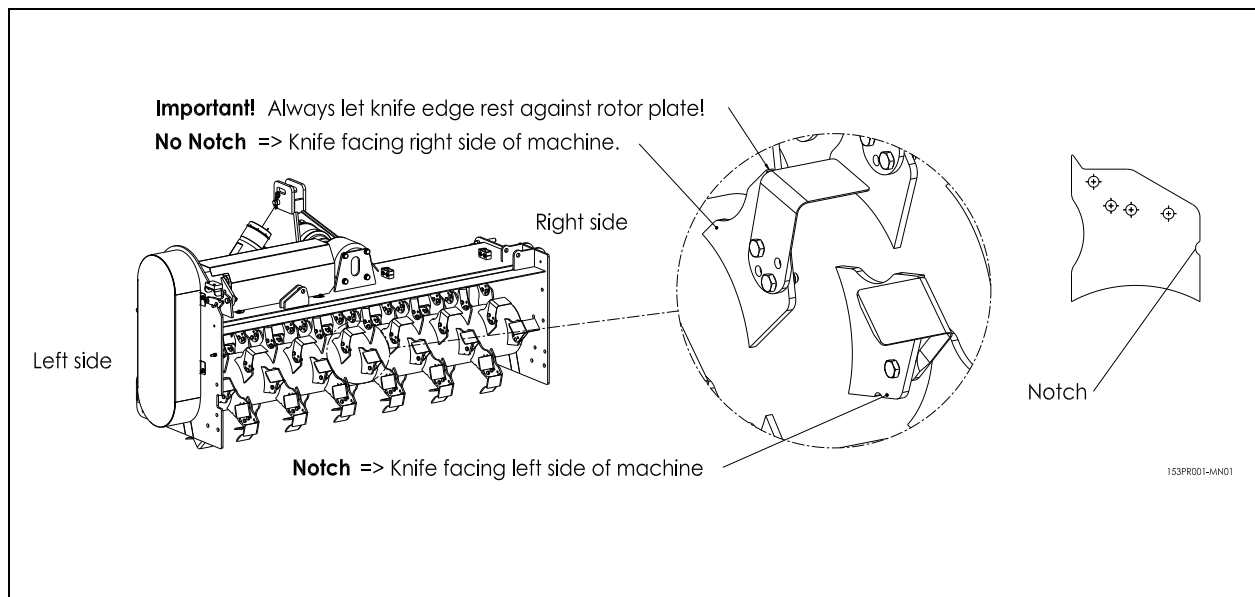

Fig. 10a

7. ADJUSTING THE WORKING DEPTH

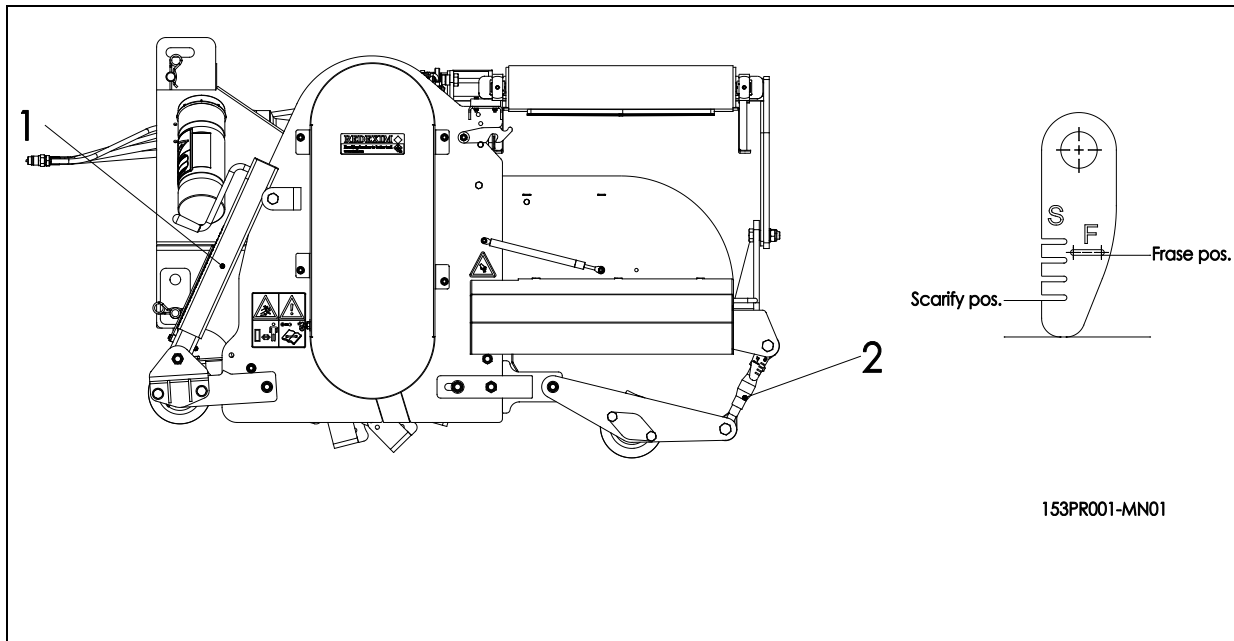

Figure 11

The working depth is adjusted by adjusting the front and the rear roller.

For the frase operation, the rear roller must be set different then in the scarifying position.

Frase operation:

1. Adjust the rear spindles 2 at the Frase position, use the indicator (see Figure 11) and lock the spindles by turning the spindle nut
2. Adjust the front spindles 1 on both sides of the machine to the desired working depth is reached.
3. Inspect the working depth by using the machine for a few meters.
If necessary, adjust the working depth.

Scarify operation:

1. Adjust the rear spindles 2 at the Scarify position, use the indicator (see Figure 11) and lock the spindles by turning the spindle nut
2. Adjust the front spindles 1 on both sides of the machine to the desired working depth is reached.
3. Inspect the working depth by using the machine for a few meters.
If necessary, adjust the working depth.



If the conveyor belt is lowered the weight of the machine shifts to this side. Partly due to the additional mass of the material to be discharged more material can be removed.

This can be compensated by turning spindles 1 and 2 on this side to set the machine slightly shallower.

8. TRANSPORTING THE TURF-STRIPPER

The user is responsible for transporting the Turf-Stripper in back of the tractor over public roads. Verify the national legislation regarding the regulations.

On open fields while the machine is raised and if circumstances allow this, the maximum permitted speed is 12 km/h (8 mph) due to the weight of the Turf-Stripper.

A higher speed can be dangerous for the driver and/or the public and can even damage the machine.



Make sure that the uppermost top rod is attached and is pressurized in the transport position (position 5)! See Chapter 4.0, figure 9. If this is not done, the machine can incur serious damage.



Attention: the transport belt has to be tipped up!



When the machine is raised off the ground, the front axle of the tractor has to support minimum 20% of its weight.

9. DRIVING SPEED

The driving speed depends on the conditions and the required result. It is maximum 3 km/h (1.8 mph).

It is NOT recommended to drive faster due to the fact that excessive wear & tear and damage can occur to the machine and to the subsoil.

10. USING THE TURF-STRIPPER





Before using the Turf-Stripper in a location, you should check the following items:

1. Are there loose objects in the field? First remove these objects.
2. Are there slopes? The maximum slope is 20 degrees for this machine.
3. Always go from top to bottom.
4. Is there danger of flying objects (e.g., balls) that distract the attention of the driver? If so, the Turf-Stripper **CANNOT** be used.
5. Is there danger of sinking/sliding away? If so, postpone the processing until conditions improve.
6. Are there hard objects in the ground? If so, use the Turf-Stripper with a low PTO speed and adjust the working depth.
7. If the soil is very wet, postpone the activities until conditions improve.

11. START/STOP PROCEDURE

The start procedure is **VERY** important. If this procedure is not executed as described below, it might result in serious damage to the machine.

The start procedure is as follows:

1. Check the Turf-Stripper for loose components and look whether all components function properly.
 **If loose components are observed or components do not function properly, the problems must be solved *before* using the Turf-Stripper!**
2. Drive to the spot where the processing should take place.
 **Attention: the transport belt has to be tipped up!**
3. Lower the machine onto the ground.
4. Fold the transport belt out by activating the hydraulic outlet of the tractor.
 **Make sure that the tractor is blocked well and cannot move on its own accord!**
 **Switch off the tractor before descending!**
5. Adjust the working depth as described in Chapter 7.0.
6. If required, the top rod can be placed in the slotted hole (4) in the towing position (see Chapter 4.0, figure 9).
7. Raise the Turf-Stripper slightly so that the knives just don't touch the ground and engage the tractor in the proper gear.
8. Activate the hydraulic outlet of the tractor in order to let the transport belts turn.
9. Adjust the tractor engine to around 1200 rpm and switch on the PTO.
10. Slowly lower the machine until it reaches the required working depth.
11. Drive forwards and increase the rotational speed until the PTO rotational speed of 540 rpm is achieved.
12. For the first track:
Check whether the required working depth is achieved. If necessary, adjust the working depth as described in Chapter 7.0.

Stopping occurs as follows:

1. Decrease the engine revs to approx. 1200 rpm.
2. Lift the machine slightly off the ground.
3. Switch the PTO off as soon as the knives no longer touch the subsoil.
4. Close the hydraulic outlet of the tractor (used for operating the transport belts).
5. Fold the transport belt in by activating the hydraulic outlet of the tractor.
6. Lift the machine even more.
7. Go to the next location and start again as described above.

12. DETACHING THE TURF-STRIPPER

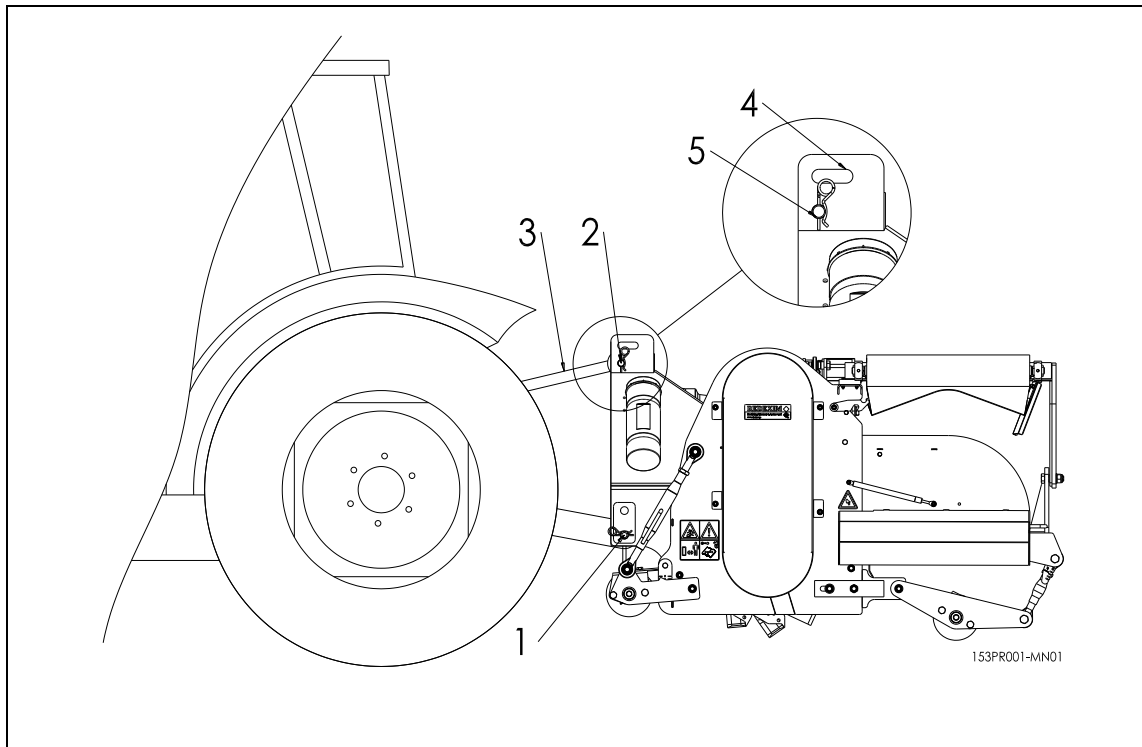

Figure 12

The machine can be detached from the tractor in the following manner (See Figure 12):

1. Drive the Turf-Stripper to a parking area with a firm/flat surface.
 - ⚠ **Make sure that the tractor is blocked well and cannot move on its own accord!**
 - ⚠ **Switch off the tractor before descending!**
 - ⚠ **Attention: the transport belt has to be tipped up!**
2. Adjust the height of the rollers so that the machine stands above the ground (see Chapter 6.0).
3. Lower the machine onto the ground.
4. Make sure that the machine cannot move on its own accord by blocking the rear roller.
5. Remove the hydraulic hoses.
6. Remove the top rod (3).
7. Loosen the PTO at the side of the tractor.
8. Disconnect the lower connecting arms of the tractor.
 - ⚠ **Make sure that the Turf-Stripper stands stable and cannot roll away and/or slide off!**
9. Start the tractor and drive off.

13. TROUBLE SHOOTING (PROBLEM ANALYSIS)

Problem	Possible cause	Solution
Machine vibrates.	<ul style="list-style-type: none"> - Obstacle(s) between the knives - Worn or broken knives. - Rotor imbalanced. 	<ul style="list-style-type: none"> - Remove the obstacle(s). - Replace with new knives. - Balance or replace the rotor.
Working depth is not achieved.	<ul style="list-style-type: none"> - Working depth is not adjusted correctly. - Subsoil is too hard. - Driving speed is too high. 	<ul style="list-style-type: none"> - Adjust the working depth properly. - Lower the driving speed or pass over the soil more than once. - Lower the driving speed.
Too coarse processing of the soil	<ul style="list-style-type: none"> - Driving speed is too high. - Subsoil is too wet. 	<ul style="list-style-type: none"> - Decrease the driving speed. - Wait for better conditions.
Rotor is jammed.	<ul style="list-style-type: none"> - Subsoil is too wet. - Obstacle(s) between the knives - Driving speed is too high. - Too much overgrowth 	<ul style="list-style-type: none"> - Wait for better conditions. - Remove the obstacle(s). - Decrease the driving speed. - Cut the overgrowth.
Rotor does not turn.	<ul style="list-style-type: none"> - The V-belts that drive the rotor slip. - Machine is adjusted too deep. 	<ul style="list-style-type: none"> - Pull the V-belts taut. - Adjust the machine to less depth.
Transport belt cannot cope with the quantity of material.	<ul style="list-style-type: none"> - Driving speed is too high. - Transport belt turns too slowly. - Working depth is too deep. 	<ul style="list-style-type: none"> - Lower the driving speed. - Increase the oil flow of the tractor. - Decrease the working depth.

14. MAINTENANCE

Time schedule	Check/Grease point	Method
Before every use	<ul style="list-style-type: none"> - Check for loose bolts/nuts. - Check the oil level in the gearbox. - Presence and readability of the safety stickers - Loose hanging parts around the PTO - Check for hydraulic defects. - Check for cracks/defects in the transport belts. 	<ul style="list-style-type: none"> - Tighten loose bolts/nuts with the correct tightening moment. - Use SAE140. - Replace these if not present or damaged. - Tighten the parts so that they cannot reach the PTO. - Repair or replace, if needed. - Repair or replace, if needed.
After every use	<ul style="list-style-type: none"> - Clean the machine. - Grease the rotor bearings. 	<ul style="list-style-type: none"> - Watch out for the bearings if a high-pressure sprayer is used. - 1 shot EP2 (see Figure13)
After the first 20 working hours (new or repaired)	<ul style="list-style-type: none"> - Lubricate the PTO and bearings. - Check for loose bolts/nuts. - Check the oil level in the gearbox. - Check the gearbox for oil leakage. - Loose hanging parts around the PTO - Check the tension of the V-belts. 	<ul style="list-style-type: none"> - Use EP2 grease - Tighten loose bolts/nuts with the correct tightening moment. - Use SAE140. - Repair the leaks/damaged parts. - Replace the seals/sealing paste. - Tighten the parts so that they cannot reach the PTO. - If needed, adjust the tension (see Section 13.2).
After every 50 working hours	<ul style="list-style-type: none"> - Lubricate the PTO and bearings of the machine. - Check for loose bolts/nuts. - Check the oil level in the gearbox. It has to reach at least the halfway mark of the gauge. - Check the gearbox for oil leakage. - Loose hanging parts around the PTO - Check the tension of the V-belts. 	<ul style="list-style-type: none"> - Use EP2 grease (see Figure 13) - Tighten loose bolts/nuts with the correct tightening moment. - Use SAE140. - Repair the leaks/damaged parts. - Replace the seals/sealing paste. - Tighten the parts so that they cannot reach the PTO. - If needed, adjust the tension (see Section 13.2).
After every 500 working hours	<ul style="list-style-type: none"> - Change the oil in the gearbox. 	<ul style="list-style-type: none"> - Use SAE140.

14.1 LUBRICATING POINTS

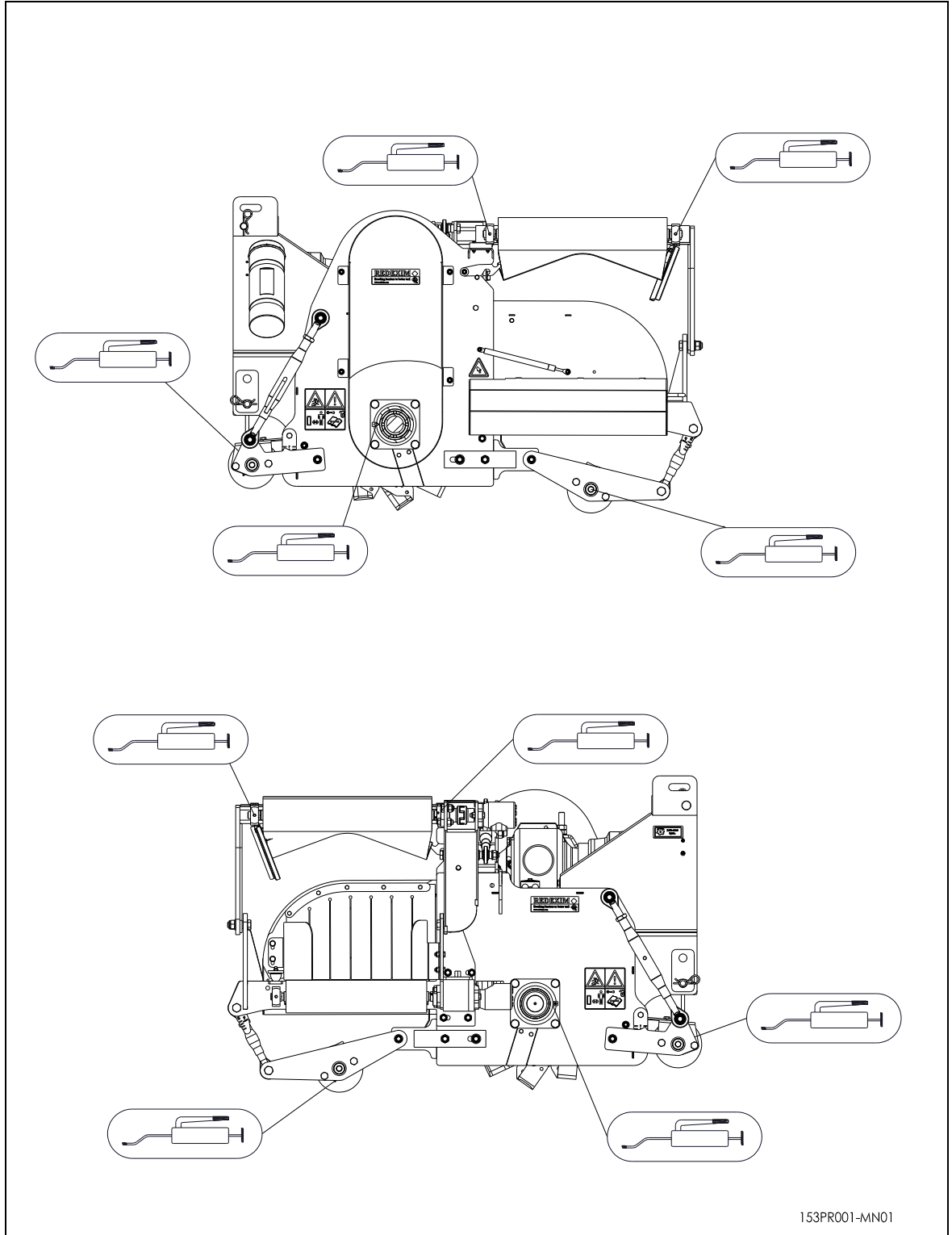

Figure 13

14.2 ADJUSTING THE TENSION OF THE V-BELTS

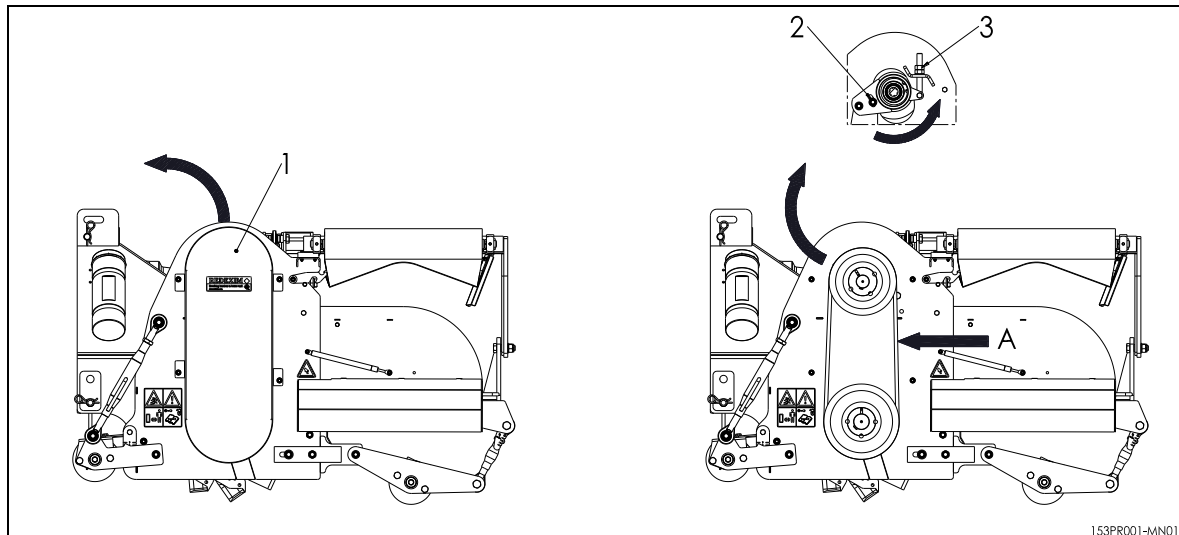

Figure 14

The Turf-Stripper is standard equipped with adjustable tension pulleys that keep the V-belts taut. Depending on the intensity of using the machine, the driveline could be affected by wear and tear. These V-belts should then be tightened.

Adjustment is carried out as follows (see Figure 14):

⚠ Make sure that the Turf-Stripper is blocked well and cannot move on its own accord!

⚠ Make sure that the PTO is detached from the Turf-Stripper!

1. Remove the safety guard (1).
2. Check the tension of the V-belt by pushing point A with a pressure of 7.5 kg (16.5 lbs). The stretch should be 12.4 mm (0.5") per V-belt.
If the tension is correct proceed to point 8 else proceed to point 3.
3. Loosen the lock nut (3).
4. Loosen the nuts (2) one turn so that the tensioning device can rotate (both sides of the bearing bridge).
5. Adjust the lock nut (3) and use it to adjust the tension of the V-belts.
6. Tighten the lock nut (3).
7. Tighten the nuts (2) at both sides of the bearing bridge.
8. Put the safety guard back in its place.

14.3 CONVEYOR BELT ALIGNMENT

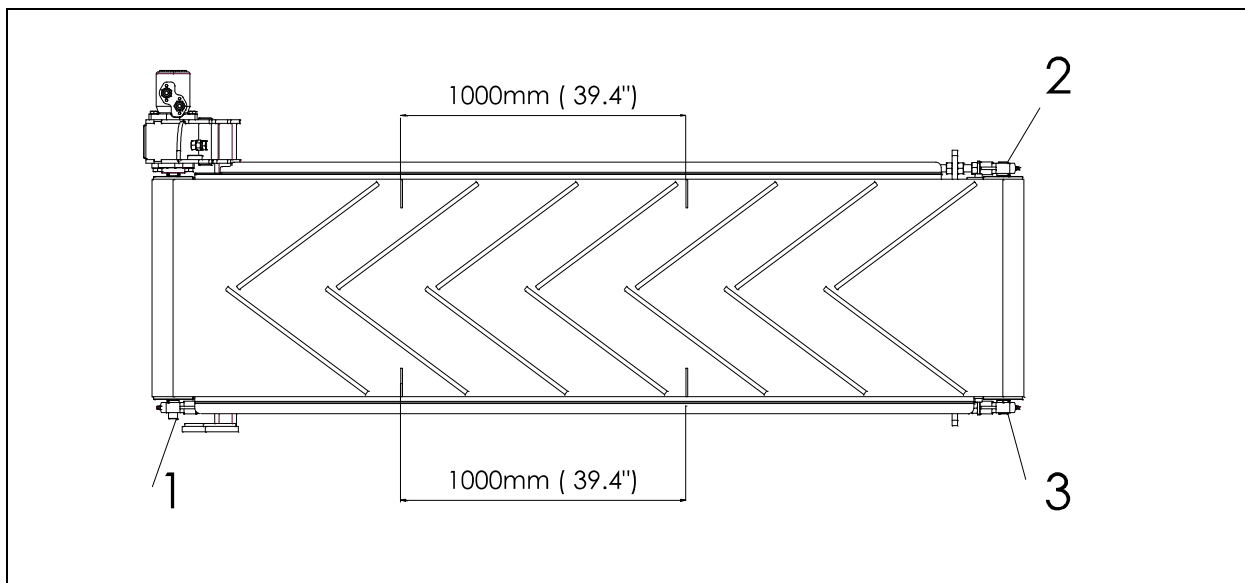

Figure 15

If the conveyor belt starts slipping or moving sideways after a while or after new installation, please use the instruction as described below for re-tensioning: (See fig. 1)

1. At first check if the rollers and inside of the conveyor belt are clean. If necessary clean the polluted parts.
2. Un-tension the belt and place on both sides of the belt 2 measure marks on a distance of 1000mm (39.4").
3. Adjust the spanners (2+3) on both sides evenly till the distance between the marks has increased to an initial dimension of 1004mm (39.5"). Carry out adjustments on both sides in small steps.
4. Run the conveyor belt only slowly so that any run off tendency can be detected quickly and rectified before any damage occurs.
5. If the belt keeps slipping adjust the spanners evenly till a maximum of 1010mm (39.8")
6. If the conveyor belts tends to move to the left give a little more tension on the left spanner (2). And if the conveyor belt moves to the right give a little more tension to the right spanner (3). Carry out adjustments in small steps.
7. After each adjustment, allow the belt to rotate for at least 10 rotations to position itself to the new alignment before making any further corrections.
8. If the belt is working properly again check if the spanners are securely locked against moving.

15. OPTIONAL: SCARIFY KNIVES (ROTOR 488.556.184)

The Turf-Stripper 1600 comes standard with frasse blades, but can also be equipped with scarifying blades for scarifying the surface.

The slit distance between the blades is divided into four distances, namely 25mm (1"), 50 mm (2"), 75mm (3") and 100mm (4").

For numbers, ordering information and rotor identification, see the parts manual.

How the dividing on the rotor will be to obtain the slit distance is shown in the following tables.

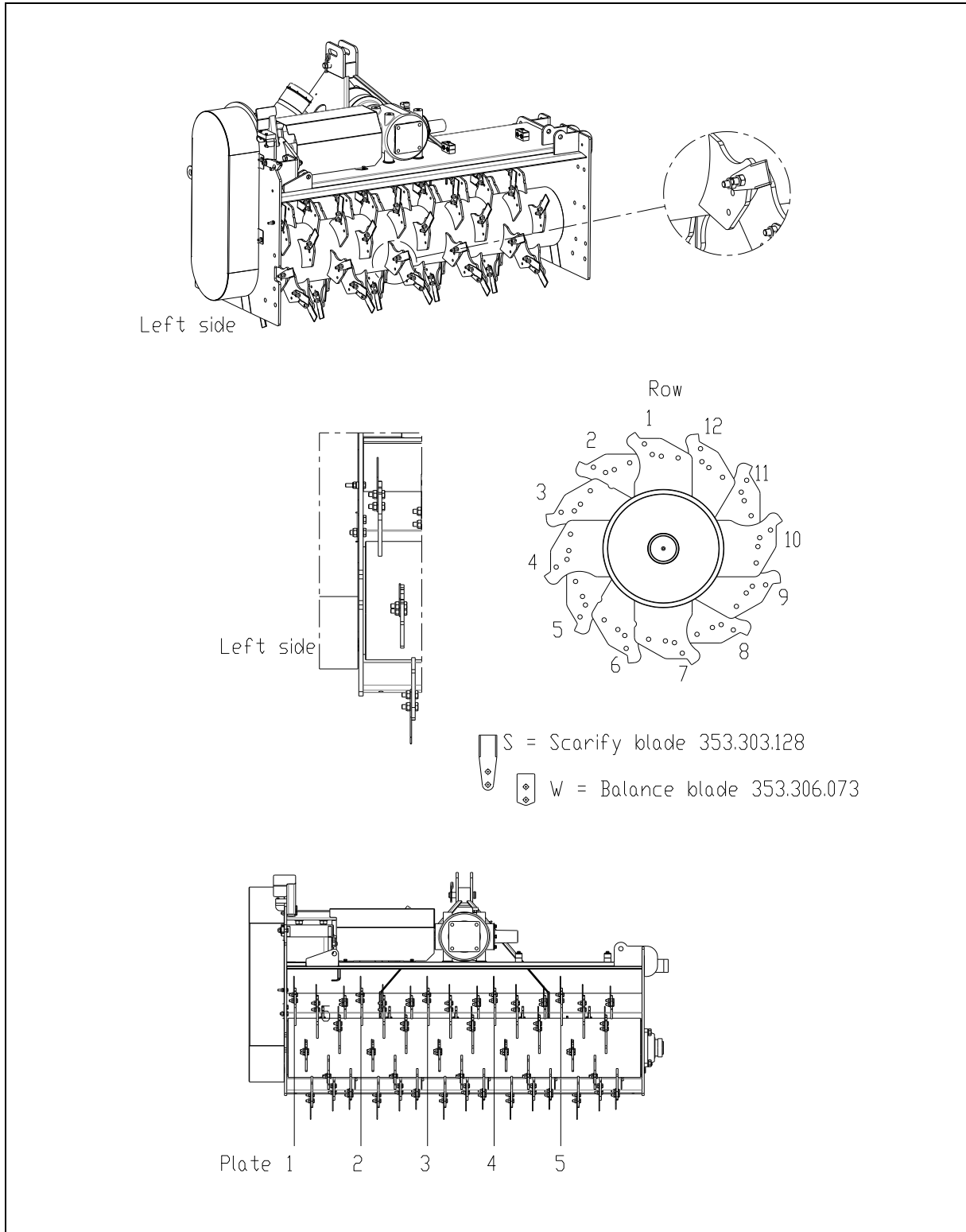

Fig 16.

In order to avoid imbalance an balance weight is used on the distance at 50 mm (2 "), 75mm (3") and 100 mm (4 "). This balance weight is indicated in the table as " W ".

Blades are marked with "S"

If there is no indication in the table is displayed, it means that nothing is installed in this position.



Row 1 which starts in the table is the row closest abutting the left side plate (30mm (1.2 "). Use this as the start position and count further as shown in figure 15



Do not forget the balance weights. Without an imbalance of the rotor can occur which may cause damage to the Turf-Stripper and the surface.

Slit distance: 25mm (1") Equip all plates with knives.

Slit distance: 50mm (2")

Plate →	1	2	3	4	5
Row ↓					
1	S	S	S	S	S
2	W	W	W	W	W
3	W	W	W	W	W
4	W	W	W	W	W
5	W	W	W	W	W
6	W	W	W	W	W
7	W	W	W	W	W
8	S	S	S	S	S
9	S	S	S	S	S
10	S	S	S	S	S
11	S	S	S	S	S
12	S	S	S	S	S

Total: 30 Scarifying blades 353.303.128
30 Balance weights 353.306.073

Slit distance: 75mm (3")

Plate → Row ↓	1	2	3	4	5
1	S	S	S	S	S
2	S	S	S	S	S
3	W	W	W	W	W
4					
5					
6					
7	S	S	S	S	S
8	W	W	W	W	W
9	S	S	S	S	S
10					
11					
12					

Total: 20 Scarifying blades 353.303.128
10 Balance weights 353.306.073

Slit distance: 100mm (4")

Plate → Row ↓	1	2	3	4	5
1	S	S	S	S	S
2					
3					
4					
5	W	W	W	W	W
6	W	W	W	W	W
7	W	W	W	W	W
8					
9					
10					
11	S	S	S	S	S
12	S	S	S	S	S

Total: 15 Scarifying blades 353.303.128
15 Balance weights 353.306.073